



Battery May Discharge

Product: Workman® HDX Automatic

September 22, 2016

Models:

Serial Numbers:

07390

314000101-316009999

07390H

314000101-316009999

07390TC

314000101-316009999

Situation:

The Workman HDX Automatic uses a 25 amp charging system that may not provide enough amperage under certain conditions. When additional accessories are added, these components may over tax the charging system. Also, at low idle, the charging system may not deliver enough charging amperage when steady loads occur (i.e. vehicle headlights used for work lights). These electrical loads may cause a battery discharge, and over time, can discharge the battery so much that it leads to a no-start condition.

Instructions:

Please contact your local Toro Commercial Products Distributor Service Group and reference the Commercial Service Bulletin, “*Vehicles 06-03- Battery May Discharge*”, dated 9/22/2016. This document details the installation of the optional kit *Alternator Kit (133-0575)* to address this complaint.



Alternator Kit
Workman® HDX-Auto Utility Vehicle
 Model No. 133-0575

Form No. 3399-376 Rev A

Installation Instructions

▲ WARNING

CALIFORNIA
Proposition 65 Warning

This product contains a chemical or chemicals known to the State of California to cause cancer, birth defects, or reproductive harm.

Installation

Loose Parts

Use the chart below to verify that all parts have been shipped.

Procedure	Description	Qty.	Use
1	No parts required	–	Prepare the machine.
2	No parts required	–	Disconnect the hydraulic pump and remove the coupler assembly.
3	No parts required	–	Remove the adapter plate.
4	Alternator pulley Alternator belt Hex socket flat head screw (M8 x 20 mm)	1 1 2	Install the alternator pulley and belt.
5	No parts required	–	Install the coupler assembly.
6	Alternator-bracket template	1	Drill holes for the alternator bracket.
7	Alternator bracket Alternator Spacer Hex-head screw (3/8 x 2-3/4 inches) Flat washer (7/16 inch) Flange nut (3/8 inch) Hex-head flange screw (M8 x 20 mm) Hex-head flange screw (1/4 x 3/4 inch) Flange nut (1/4 inch)	1 1 1 1 1 1 6 6	Install the alternator.
8	No parts required	–	Connect the hydraulic pump.
9	Alternator wire harness	1	Connect the kit and engine wire harnesses to the alternator.

© 2016—The Toro® Company
 8111 Lyndale Avenue South
 Bloomington, MN 55420

Register at www.Toro.com.



Original Instructions (EN)
 Printed in the USA
 All Rights Reserved



Procedure	Description	Qty.	Use
10	No parts required	-	Connect the battery.
11	No parts required	-	Test the alternator.

Note: Determine the left and right sides of the machine from the normal operating position.

1

Preparing the Machine

No Parts Required

Procedure

1. Park the machine on a level surface, set the parking brake, shut off the engine, and remove the key.
2. Disconnect the negative battery cable; refer to your *Operator's Manual*.

2

Disconnecting the Hydraulic Pump and Removing the Coupler Assembly

No Parts Required

Procedure

1. Loosen the 2 set screws on the hydraulic-pump hub (Figure 1).

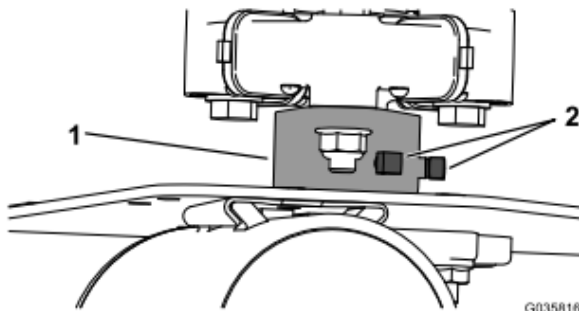

Figure 1

1. Hydraulic-pump hub
2. Set screws

2. Remove the 4 bolts and nuts from the hydraulic pump (Figure 2).

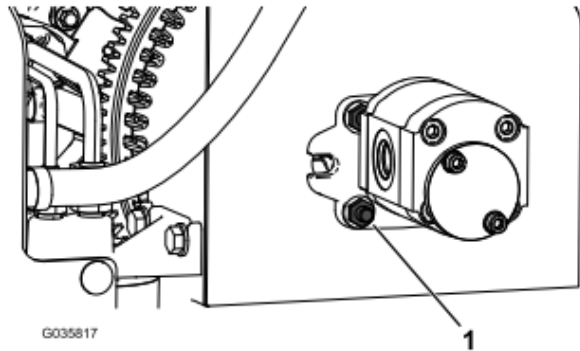

Figure 2

1. Bolt and nut

3. Separate the hydraulic pump from the coupler and move the hydraulic pump out of the way.

Note: Retain the hardware.

4. Remove the 2 flange nuts from the hydraulic-pump hub (Figure 3).

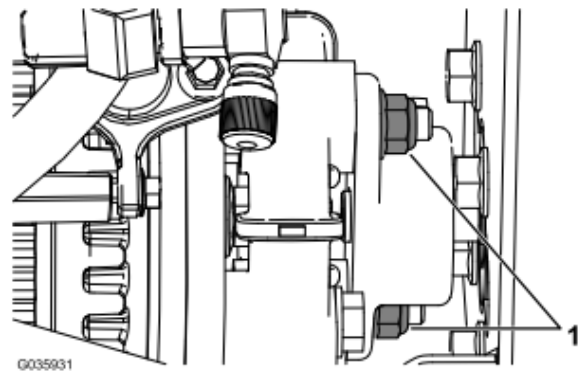

Figure 3

1. Flange nuts

5. Remove the 2 bolts and 2 washers from the coupler assembly (Figure 4).

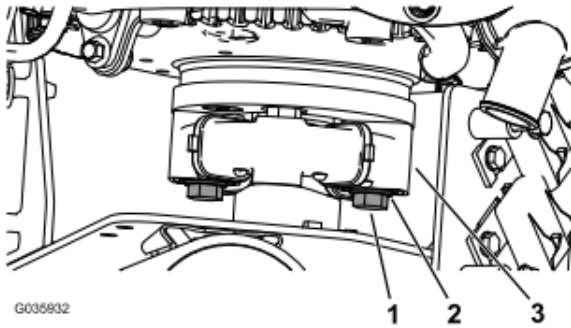

Figure 4

- 1. Bolt
- 2. Washer
- 3. Coupler assembly

6. Remove the coupler assembly.

3

Removing the Adapter Plate

No Parts Required

Procedure

1. Remove the hex socket flat head screws from the adapter plate (Figure 5).

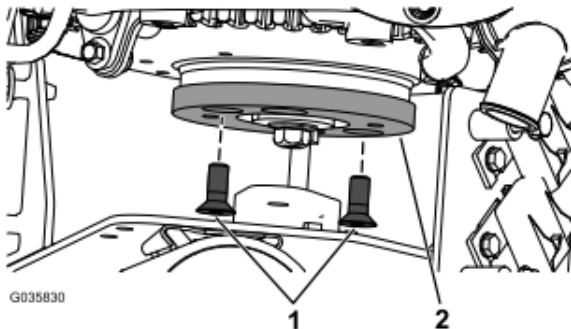

Figure 5

- 1. Hex socket flat head screws
- 2. Adapter plate

2. Remove the adapter plate (Figure 5).

Note: Discard the adapter plate and screws.

4

Installing the Alternator Pulley and Belt

Parts needed for this procedure:

1	Alternator pulley
1	Alternator belt
2	Hex socket flat head screw (M8 x 20 mm)

Procedure

1. Install the alternator belt onto the alternator pulley (Figure 6).

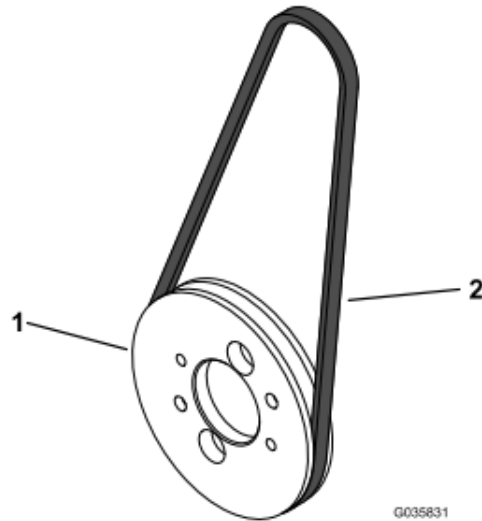

Figure 6

- 1. Alternator pulley
- 2. Alternator belt

2. Install the alternator pulley to the motor with the 2 hex socket flat head screws (M8 x 20 mm) as shown in Figure 7.

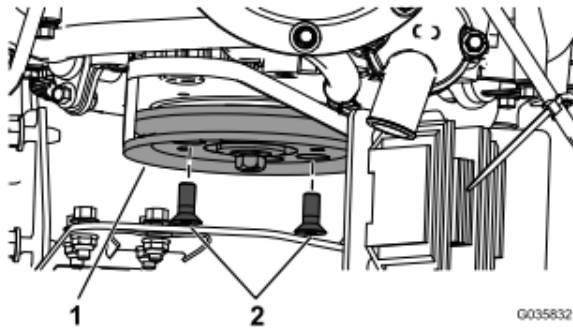

Figure 7

G035832

1. Alternator pulley
2. Hex socket flat head screws (M8 x 20 mm)

3. Apply thread-locking compound to the 2 hex socket flat head screws (M8 x 20 mm) and torque them to 26 to 31 N·m (19 to 23 ft-lb).

5

Installing the Coupler Assembly

No Parts Required

Procedure

1. Apply thread-locking compound to the 2 bolts removed in [2 Disconnecting the Hydraulic Pump and Removing the Coupler Assembly](#) (page 2).
2. Install the 2 bolts and washers, and torque the bolts to 1,483 to 1,907 N·cm (131 to 169 in-lb).
3. Install the 2 nuts removed in [2 Disconnecting the Hydraulic Pump and Removing the Coupler Assembly](#) (page 2) and torque the nuts to 1,483 to 1,907 N·cm (131 to 169 in-lb).

6

Drilling Holes for the Alternator Bracket

Parts needed for this procedure:

- | | |
|---|-----------------------------|
| 1 | Alternator-bracket template |
|---|-----------------------------|

Procedure

Using the alternator-bracket template, drill 2 holes (5/16 inch) into the hydraulic-pump bracket ([Figure 8](#)).

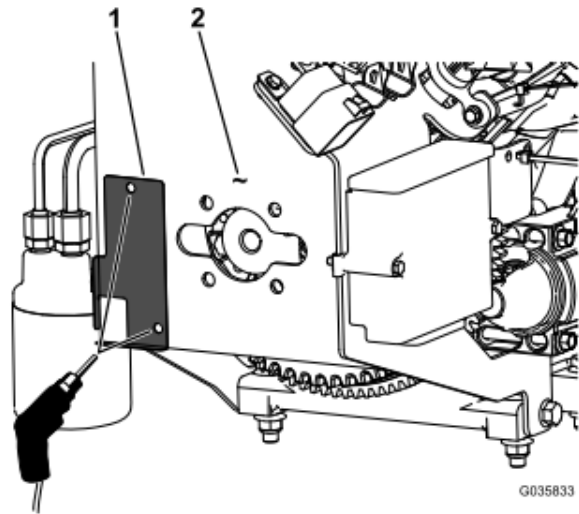

Figure 8

G035833

1. Alternator-bracket template
2. Hydraulic-pump bracket

7

Installing the Alternator

Parts needed for this procedure:

1	Alternator bracket
1	Alternator
1	Spacer
1	Hex-head screw (3/8 x 2-3/4 inches)
1	Flat washer (7/16 inch)
1	Flange nut (3/8 inch)
1	Hex-head flange screw (M8 x 20 mm)
6	Hex-head flange screw (1/4 x 3/4 inch)
6	Flange nut (1/4 inch)

Procedure

1. Move the carbon canister to the right side of the machine and use cable ties to secure it to the hydraulic hardlines away from moving or hot parts (Figure 9).

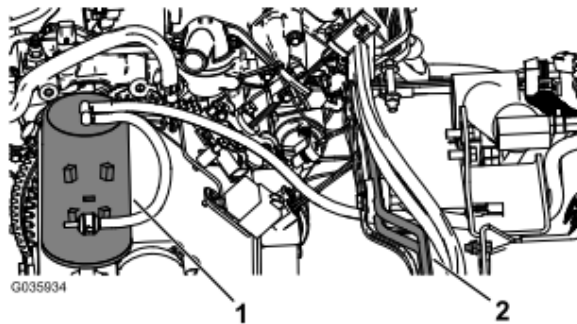

Figure 9

1. Carbon canister
2. Hydraulic hardlines

2. Install the alternator bracket to the hydraulic-pump bracket with the 6 hex-head flange screws (1/4 x 3/4 inch) and 6 flange nuts (1/4 inch) as shown in Figure 10.

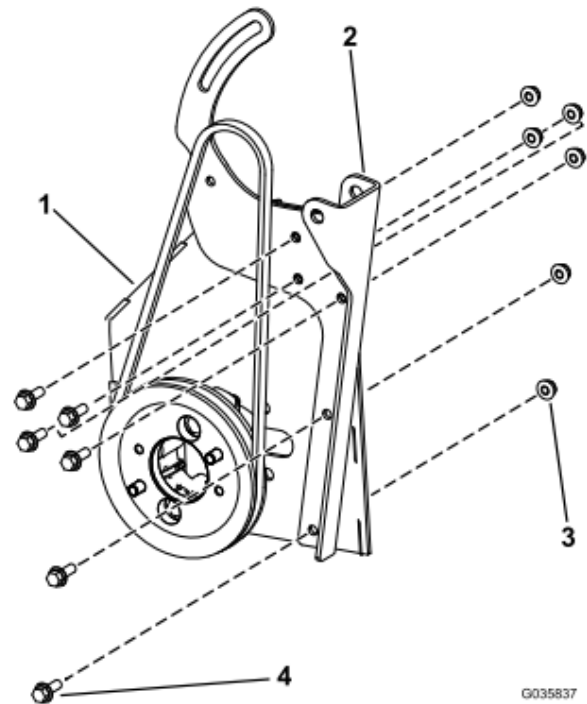
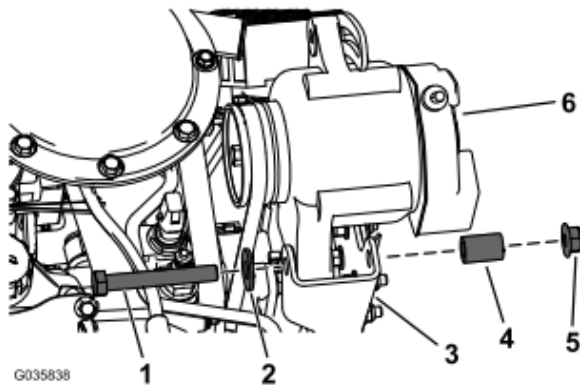

Figure 10

1. Hydraulic-pump bracket
2. Alternator bracket
3. Flange nut (1/4 inch)
4. Hex-head flange screw (1/4 x 3/4 inch)

3. Install the alternator to the alternator bracket with the hex-head screw (3/8 x 2-3/4 inches), flat washer (7/16 inch), spacer, and flange nut (3/8 inch) as shown in Figure 11.

Note: When installing with the Cab Heater Kit, the "T" in the coolant line needs to be turned to direct the hose away from the alternator.



G035838

Figure 11

- | | |
|--|--------------------------|
| 1. Hex-head screw (3/8 x 2-3/4 inches) | 4. Spacer |
| 2. Flat washer (7/16 inch) | 5. Flange nut (3/8 inch) |
| 3. Alternator bracket | 6. Alternator |

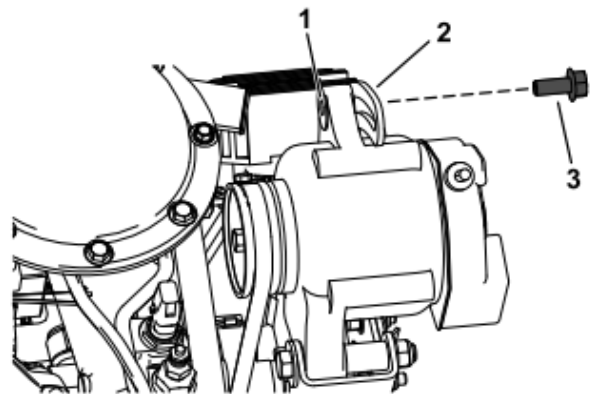

G035839

Figure 13

- | | |
|-----------------------------------|---------------------------------------|
| 1. Hole in the alternator | 3. Hex-head flange screw (M8 x 20 mm) |
| 2. Slot in the alternator bracket | |

4. Using cable ties, secure the engine crossover tube and engine wire harness away from the alternator belt (Figure 12).

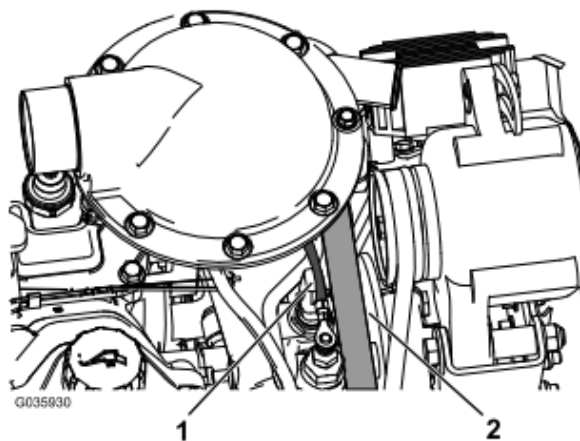

G035830

Figure 12

- | | |
|------------------------|-------------------|
| 1. Engine wire harness | 2. Crossover tube |
|------------------------|-------------------|

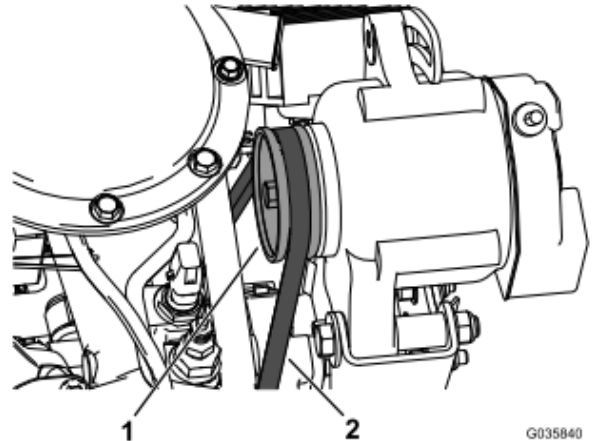

G035840

Figure 14

- | | |
|-----------|--------------------|
| 1. Pulley | 2. Alternator belt |
|-----------|--------------------|

5. Loosely install the hex-head flange screw (M8 x 20 mm) through the slot in the alternator bracket and the hole in the alternator (Figure 13).

7. Tension the alternator belt and ensure that it has 1.25 cm (1/2 inch) of flex when applying 4.5 kg (10 lb) of force at mid-span.
8. Tighten the hex-head flange screw (M8 x 20 mm).

8

Connecting the Hydraulic Pump

No Parts Required

Procedure

1. Install the hydraulic pump with the 4 bolts and nuts removed in 2 Disconnecting the Hydraulic Pump and Removing the Coupler Assembly (page 2).
2. Tighten the 2 set screws on the hydraulic-pump hub (Figure 1).

9

Connecting the Kit and Engine Wire Harnesses to the Alternator

Parts needed for this procedure:

1	Alternator wire harness
---	-------------------------

Procedure

1. Connect the kit wire harness to the alternator (Figure 15).

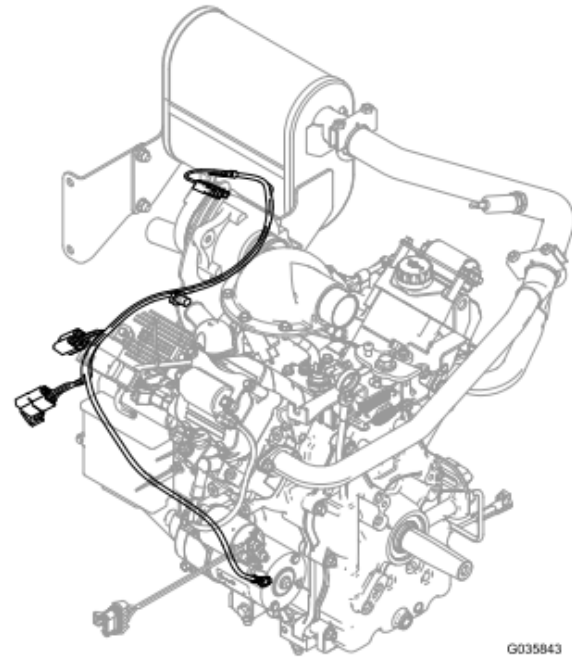

Figure 15

2. Connect the alternator wire harness to the engine wire harness (Figure 16).

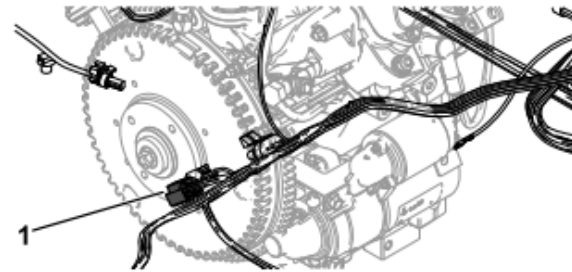

Figure 16

1. Connect the alternator wire harness to the engine wire harness here.
3. Disconnect the purple wire with the terminal ring on the starter, and secure it with electrical tape.
4. Connect the positive terminal ring to the positive terminal on the starter (Figure 15).

10

Connecting the Battery

No Parts Required

Procedure

Connect the negative battery cable; refer to your *Operator's Manual*.

11

Testing the Alternator

No Parts Required

Procedure

1. Shut off the engine and check the battery voltage.
2. Start the engine and check the battery voltage.

Note: After starting the engine, the voltage should be 13.5 to 14.5 V.