



Count on it.

Operator's Manual

Walk-Behind Rotary Broom

Model No. 38700—Serial No. 40000000 and Up

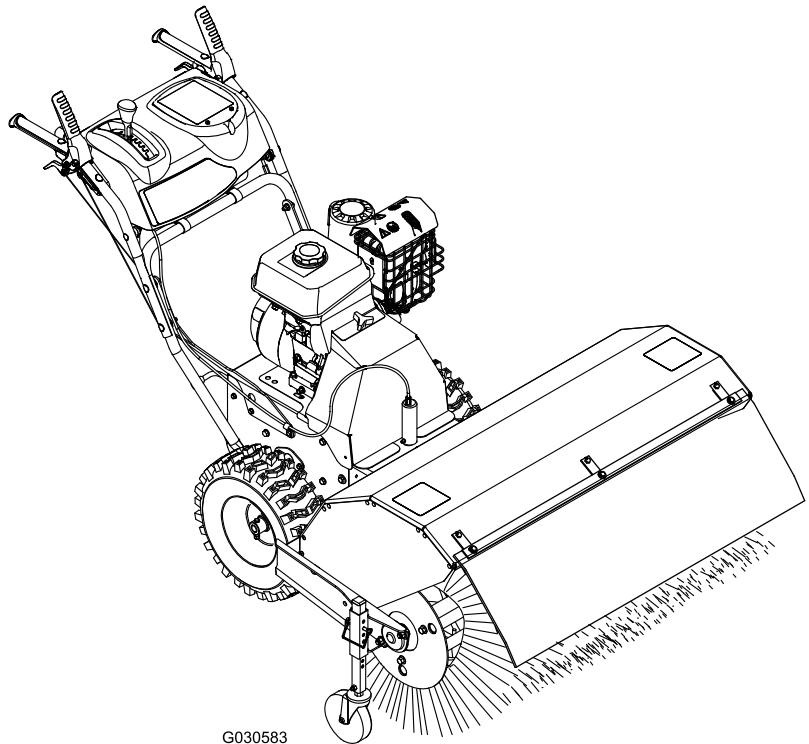

G030583



This product complies with all relevant European directives; for details, please see the separate product specific Declaration of Conformity (DOC) sheet.

It is a violation of California Public Resource Code Section 4442 or 4443 to use or operate the engine on any forest-covered, brush-covered, or grass-covered land unless the engine is equipped with a spark arrester, as defined in Section 4442, maintained in effective working order or the engine is constructed, equipped, and maintained for the prevention of fire.

▲ WARNING

**CALIFORNIA
Proposition 65 Warning**

This product contains a chemical or chemicals known to the State of California to cause cancer, birth defects, or reproductive harm.

The engine exhaust from this product contains chemicals known to the State of California to cause cancer, birth defects, or other reproductive harm.

The enclosed Engine Owner's Manual is supplied for information regarding the US Environmental Protection Agency (EPA) and the California Emission Control Regulation of emission systems, maintenance, and warranty. Replacements may be ordered through the engine manufacturer.

Introduction

To acquire a spark arrester for your machine, see your Engine Service Dealer.

This machine is intended to be used by residential homeowners or professional, hired operators. It is designed for removing snow, dust, and dirt from paved surfaces, such as driveways and sidewalks, and other surfaces for traffic on residential or commercial properties, as well as thatch from grass.

Read this information carefully to learn how to operate and maintain your machine properly and to avoid injury and machine damage. You are responsible for operating the machine properly and safely.

You may contact Toro directly at www.Toro.com for machine and accessory information, help finding a dealer, or to register your machine.

Whenever you need service, genuine Toro parts, or additional information, contact an Authorized Service Dealer or Toro Customer Service and have the model and serial numbers of your machine ready. [Figure 1](#) identifies the location of the

model and serial numbers on the machine. Write the numbers in the space provided.

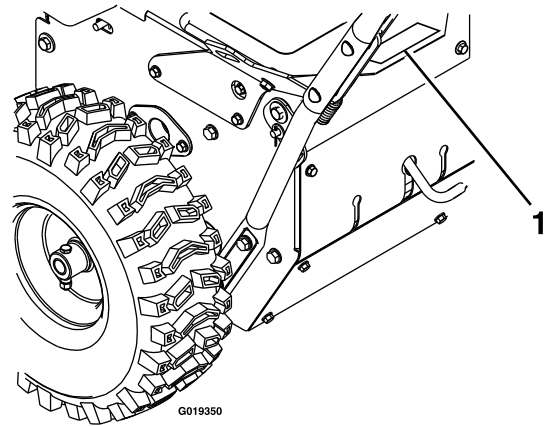

Figure 1

1. Model and serial-number location

Model No. _____

Serial No. _____

This manual identifies potential hazards and has safety messages identified by the safety alert symbol ([Figure 2](#)), which signals a hazard that may cause serious injury or death if you do not follow the recommended precautions.



Figure 2

1. Safety-alert symbol

This manual uses 2 words to highlight information.

Important calls attention to special mechanical information and **Note** emphasizes general information worthy of special attention.

Contents

Safety	4
Training	4
Preparation.....	4
Operation.....	4
Clearing a Clogged Broom.....	5
Maintenance and Storage.....	5
Sound Pressure	5
Sound Power	5
Hand/Arm Vibration	5
Slope Indicator	6
Safety and Instructional Decals	7
Product Overview	9
Controls	9
Specifications	10
Attachments/Accessories.....	10
Operation	11
Fueling the Machine	11
Operating the Engine.....	12
Driving the Machine	13
Operating the Broom.....	14
Checking the Sweeping Path	15
Adjusting the Broom Height	15
Adjusting the Broom Side Angle.....	16
Using the Alternate Caster Location	16
Clearing a Clogged Broom.....	16
Preventing Freeze-up	17
Transporting the Machine.....	17
Maintenance	18
Recommended Maintenance Schedule(s)	18
Preparing for Maintenance.....	19
Lubrication.....	19
Engine Maintenance	19
Fuel System Maintenance	22
Drive System Maintenance.....	23
Broom Maintenance	24
Maintaining the Belts	26
Maintaining the Chassis.....	28
Storage	29
Preparing the Machine for Storage	29
Removing the Machine from Storage.....	29
Troubleshooting	30

Safety

Read and understand the contents of this manual before the engine is ever started.

▲This is the safety alert symbol. It is used to alert you to potential personal injury hazards. Obey all safety messages that follow this symbol to avoid possible injury or death.

Improperly using or maintaining this machine could result in injury or death. To reduce this potential, comply with the following safety instructions.

Training

- Read the operating and service instruction manual carefully. Be thoroughly familiar with the controls and the proper use of the machine. Know how to stop the machine and disengage the controls quickly.
- Do not allow adults to operate the machine without proper instruction.

Preparation

▲ CAUTION

The operation of any powered machine can result in foreign objects being thrown into the eyes.

Always wear safety glasses or eye shields during operation or while performing an adjustment or repair.

▲ CAUTION

This machine produces sound levels in excess of 85 dBA at the operator's ear and can cause hearing loss through extended periods of exposure.

Wear hearing protection when operating this machine.

- Keep the area of operation clear of all persons, particularly small children, and pets.
- Thoroughly inspect the area where you will use the machine and remove all doormats, sleds, boards, wires, and other foreign objects.
- Do not operate the machine without wearing appropriate personal protective equipment such as hearing protection, safety glasses or goggles, dust mask, and garments. Wear footwear, which will improve traction on slippery surfaces.
- Handle fuel with care; it is highly flammable.
 - Use an approved fuel container.
 - Never add fuel to a running or hot engine.

- Fill the fuel tank outdoors with extreme care. Never fill the fuel tank indoors.
 - Secure the fuel cap after fueling and wipe up any spilled fuel.
- Let the engine and machine adjust to outdoor temperatures before starting to clear snow.

Operation

- Never allow children to operate the machine.
- Do not put hands or feet near or under rotating parts. Keep clear of the discharge opening at all times.
- Never direct discharge at bystanders or allow anyone in front of the machine.
- Take all possible precautions when leaving the machine unattended. Release the broom-drive lever, traction-drive lever, stop the engine, and remove the key.
- Always be sure of your footing, and keep a firm hold on the handles. Walk; never run.
- Never operate the machine without good visibility or light.
- Do not operate the machine while ill, tired, or under the influence of alcohol or drugs.
- Exercise caution to avoid slipping or falling, especially when operating the machine in the reverse travel direction.
- Stop the engine whenever you leave the operating position, before unclogging the broom housing, and when making any repairs, adjustments, or inspections.
- Exercise extreme caution when operating on or crossing gravel drives, walks, or roads. Stay alert for hidden hazards or traffic.
- Never operate the machine at high transport speeds on slippery surfaces. Use care when reversing.
- Do not clear snow, dirt, or thatch across the face of slopes. Exercise extreme caution when changing direction on slopes. Do not attempt to clear steep slopes.
- Never operate the machine near glass enclosures, automobiles, window wells, drop offs, etc. without proper adjustment of the snow discharge angle. Keep children and pets away.
- Do not overload the machine capacity by attempting to clear snow, dirt, or thatch at too fast of a rate.
- Do not run the engine indoors, except when starting it and for moving the machine in or out of the building. Open the outside doors; exhaust fumes are dangerous.
- When cleaning, repairing, or inspecting, ensure that the rotary broom and all moving parts have stopped. Disconnect the spark-plug wire, and keep the wire away from the plug to prevent accidental starting.
- Disengage the power to the rotary broom when the machine is transported or not in use.

- After striking a foreign object, stop the engine, remove the wire from the spark plug, thoroughly inspect the machine for any damage, and repair the damage before restarting and operating the machine.
- If the machine should start to vibrate abnormally, stop the engine and check immediately for the cause. Vibration is generally a warning of trouble.
- Never operate the machine without proper guards, plates, or other safety protective devices in place.
- Use only attachments and accessories approved by the manufacturer of the machine (such as wheel weights, counterweights, cabs, etc.).

Clearing a Clogged Broom

⚠ WARNING

The rotating broom could cause serious injury.

Always use caution when cleaning the broom.

To clear the broom:

- Park the machine on level ground, stop the engine, wait for all moving parts to stop, and remove the spark-plug wire(s).
- Sharp objects can become entangled in the bristles. Wear gloves and use caution when cleaning out the broom of foreign objects; never use your bare hands.

Maintenance and Storage

- Never attempt to make any adjustments while the engine is running (except where specifically recommended by the manufacturer).
- Check all of the fasteners at frequent intervals for proper tightness to ensure that the machine is in safe, working condition.
- Never store the machine with fuel in the fuel tank inside a building where ignition sources are present, such as hot water and space heaters, clothing dryers, etc. Allow the engine to cool before storing the machine in any enclosure.
- Always refer to the instructions in the *Operator's Manual* for important details if the machine is to be stored for an extended period.
- Maintain or replace the safety and instruction labels, as necessary.
- When operating in snow conditions, run the machine for a few minutes after throwing snow to prevent freeze up of the broom and housing.

Sound Pressure

This unit has a sound pressure level at the operator's ear of 89 dBA, which includes an Uncertainty Value (K) of 1 dBA.

Sound power level was determined according to the procedures outlined in EN ISO 11201.

Sound Power

This unit has a guaranteed sound power level of 101 dBA, which includes an Uncertainty Value (K) of 1 dBA.

Sound pressure level was determined according to the procedures outlined in ISO 11094.

Hand/Arm Vibration

Measured vibration level for left hand = 6.4 m/s²

Measured vibration level for right hand = 5.5 m/s²

Uncertainty Value (K) = 2.6 m/s²

Measured values were determined according to the procedures outlined in EN ISO 20643.

Slope Indicator

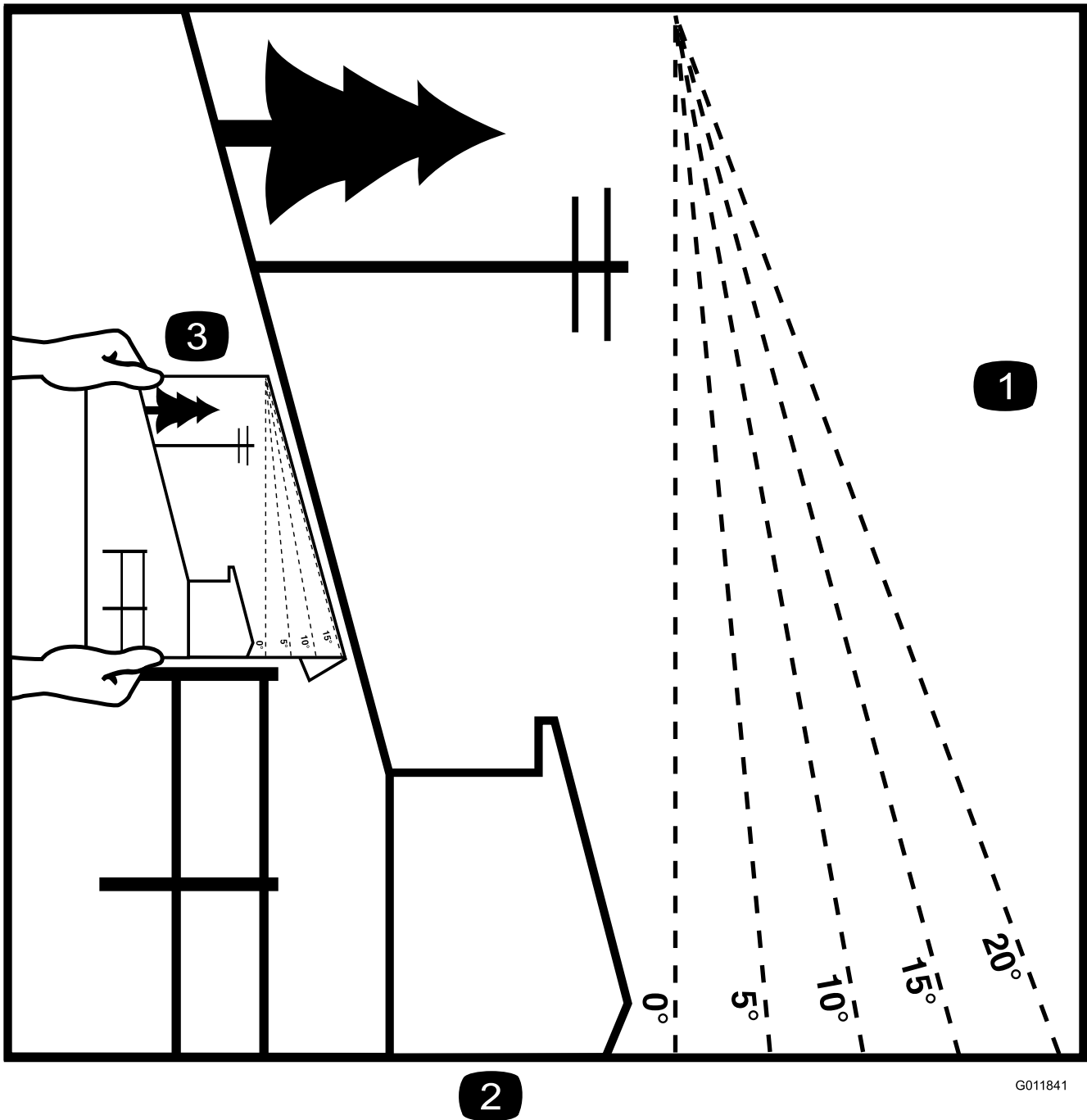
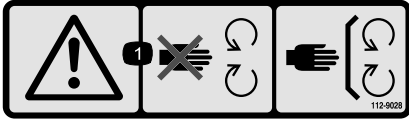

Figure 3

1. The maximum slope you can safely operate the machine on is 10° . Use the slope indicator to determine the degree of slope of hills before operating. **Do not operate this machine on a slope greater than 10° .** Fold along the appropriate line to match the recommended slope.
2. Align this edge with a vertical surface, a tree, building, fence pole, etc.
3. Example of how to compare slope with folded edge.

Safety and Instructional Decals

Important: Safety and instruction decals are located near areas of potential danger. Replace damaged decals.



112-9028

decal112-9028

1. Warning—stay away from moving parts; keep all guards in place.

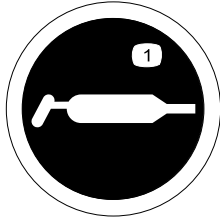

115-2903

decal115-2903

1. Grease



116-8140

decal116-8140

1. Thrown object hazard—Do not operate when people and pets are in the area.
2. Warning—Entanglement hazard—stay clear of the rotating broom.

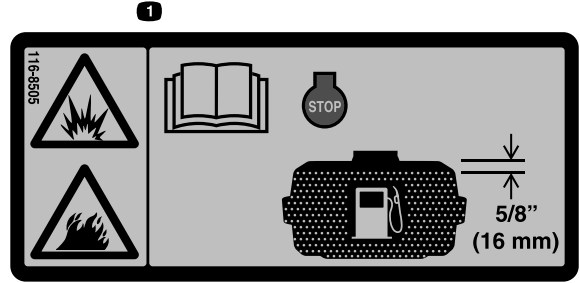

116-8505

decal116-8505

1. Explosion/Fire hazard—Read the *Operator's Manual*. Stop the engine before filling the fuel tank. Leave 16 mm (5/8 inch) at the top of the tank for fuel expansion. Do not overfill the tank.

CALIFORNIA SPARK ARRESTER WARNING

Operation of this equipment may create sparks that can start fires around dry vegetation. A spark arrester may be required. The operator should contact local fire agencies for laws or regulations relating to fire prevention requirements. 117-2718

decal117-2718

117-2718

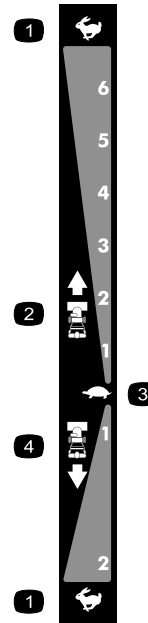

106-4525

decal106-4525

Order Part No. 112-6633

1. Fast
2. Forward speeds
3. Slow
4. Reverse speeds

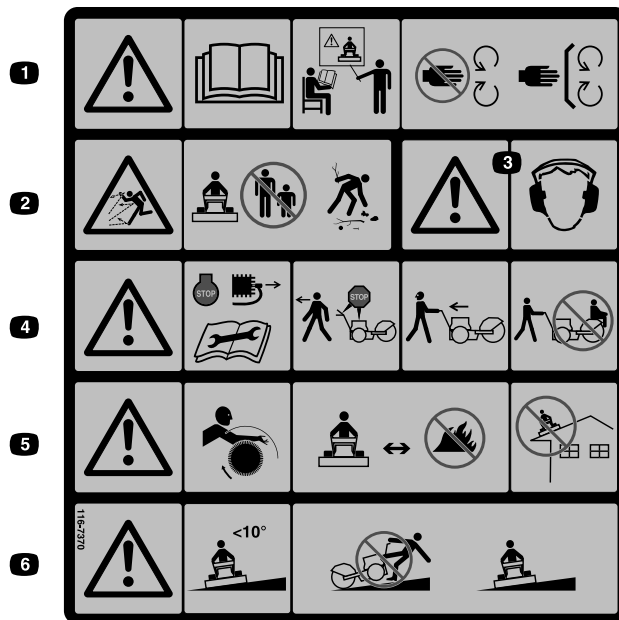

decal116-7370

116-7370

1. Warning—Read the *Operator's Manual*. Do not operate this machine unless you are trained. Stay away from moving parts; keep all guards in place.
2. Thrown object hazard—Do not operate when people and pets are in the area; pick up objects that could be thrown by broom.
3. Warning—Wear hearing protection.
4. Warning—Stop the engine and remove spark plug before adjusting, servicing, or cleaning machine and attachments. Before leaving the operator's position, disengage broom, traction drive, and stop engine. Look behind and to the side before changing directions. Do not carry passengers.
5. Warning—Entanglement hazard—stay clear of the rotating broom. Broom bristles will melt or burn—keep away from extreme heat or flame. Do not operate on any roof or other elevated surface.
6. Warning—Do not operate on slopes greater than 10 degrees. Use extreme caution when operating on slopes; operate across slopes not up and down.



decal126-0017

126-0017

1. Engage the left-turn lever to turn left.
2. Engage the traction-control lever to activate the traction drive.
3. Engage the broom-angle lever to adjust the broom.
4. Engage the PTO lever to activate the PTO.
5. Engage the right-turn lever to turn right.

Product Overview

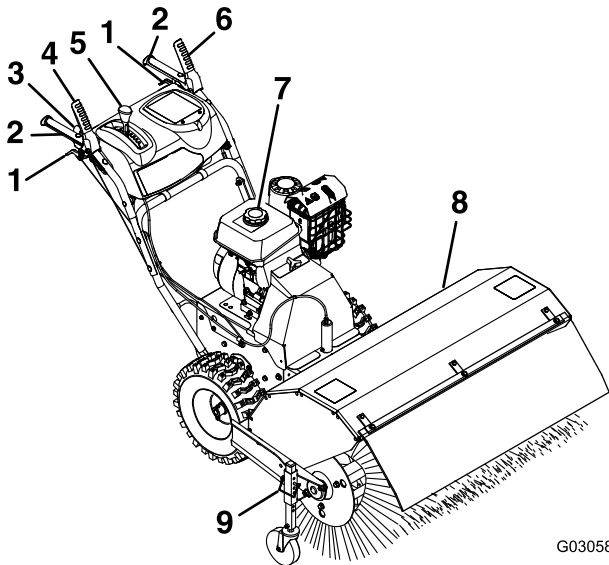

Figure 4

- | | |
|-------------------------|--------------------------------|
| 1. Wheel-clutch lever | 6. Traction-drive lever |
| 2. Handle | 7. Fuel cap |
| 3. Broom-angle lever | 8. Broom |
| 4. Broom-drive lever | 9. Broom-height-adjustment pin |
| 5. Speed-selector lever | |

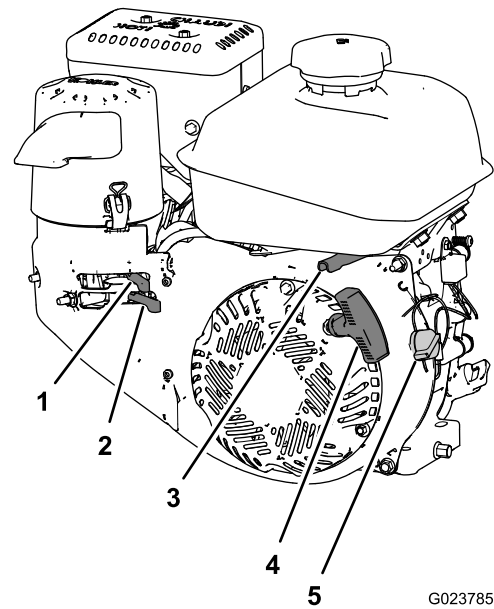

Figure 5

- | | |
|-----------------------|-------------------------|
| 1. Choke control | 4. Engine-recoil handle |
| 2. Fuel-shutoff valve | 5. Engine On/Off switch |
| 3. Throttle control | |

Controls

Determine the left and right sides of the machine from the normal operating position.

Choke Control

The choke control is the top lever located on the rear, left side of the engine above the fuel-shutoff valve (Figure 5).

The choke is used to aid in starting a cold engine. Move the lever left to the ON position for a cold start. Do not run a warm engine with the choke in the ON position.

Fuel-Shutoff Valve

Use the fuel-shutoff valve to shut off the flow of fuel when you will not use the machine for a few days, park the machine inside a building, or transport the machine to and from the job site (Figure 5).

Move the lever to the left to shut off the fuel. Move the lever to the right to turn on the fuel.

Throttle Control

The throttle control is located on the rear, right side of the engine and below the fuel tank (Figure 5).

The throttle is used to control engine speed. Moving the throttle control to the left increases the engine speed, and moving it right decreases the engine speed.

Engine On/Off Switch

Located on the right side of the engine (Figure 5).

Rotate the switch clockwise to the ON position before starting the engine. Rotate the switch counterclockwise to the OFF position to stop the engine.

Wheel-Clutch Levers

The wheel-clutch levers are located below the right and left handles.

The wheel clutch levers allow the drive to momentarily disengage to 1 or both wheels with the traction-drive lever squeezed. This allows for easier turning and maneuvering the machine (Figure 6).

Note: Squeezing both wheel clutch levers simultaneously disengages the drive to both wheels (free-wheeling). This enables you to manually move the machine backward without stopping to shift it into a reverse gear. It also allows you to maneuver and transport the machine more easily when the engine is not running.

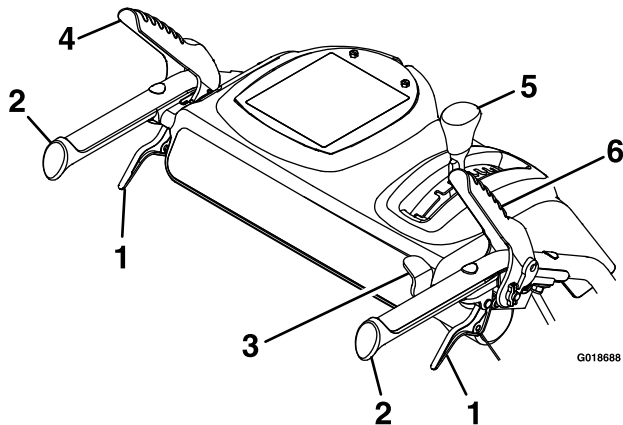

Figure 6

- | | |
|-----------------------|-------------------------|
| 1. Wheel-clutch lever | 4. Traction-drive lever |
| 2. Handle | 5. Speed-selector lever |
| 3. Broom-angle lever | 6. Broom-drive lever |

Broom-Drive Lever

The broom-drive lever is located above the right handle (Figure 6).

To engage the broom, squeeze the lever to the handle. To disengage the broom, release the right lever.

Traction-Drive Lever

The traction-drive lever is located above the left handle (Figure 6).

The traction-drive lever controls the forward and reverse motion of the machine. To engage the traction drive, squeeze the lever to the handle.

Note: Holding down the traction-drive lever against the handle engages the traction drive to both wheels.

Speed-Selector Lever

The speed-selection lever is located on the main console panel (Figure 6).

The speed selector has 6 forward and 2 reverse settings. To change speeds, release the traction-drive lever, and shift the speed-selector lever to the desired setting. The lever locks in a notch at each speed setting.

Broom-Angle Lever

The broom-angle lever is located at the right handle (Figure 6).

The broom-angle lever controls the angle lock. The broom angle can be locked into 3 positions: straight ahead, or angled to the left or right 19°.

Specifications

Width	118 cm (46.5 inches)
Length	185.5 cm (73 inches)
Height	105.5 cm (41.5 inches)
Weight	146.5 kg (323 lb)
Engine speed (no load)	Full speed: 3600 ± 100 rpm

Attachments/Accessories

A selection of Toro approved attachments and accessories is available for use with the machine to enhance and expand its capabilities. Contact your Authorized Service Dealer or Distributor or go to www.Toro.com for a list of all approved attachments and accessories.

Operation

Fueling the Machine

Fuel tank capacity: 4.1 L (1.0 US gallon)

- For best results, use only clean, fresh (less than 30 days old), unleaded gasoline with an octane rating of 87 or higher ((R+M)/2 rating method).
- **Ethanol:** Gasoline with up to 10% ethanol (gasohol) or 15% MTBE (methyl tertiary butyl ether) by volume is acceptable. Ethanol and MTBE are not the same. Gasoline with 15% ethanol (E15) by volume is not approved for use. **Never use gasoline that contains more than 10% ethanol by volume**, such as E15 (contains 15% ethanol), E20 (contains 20% ethanol), or E85 (contains up to 85% ethanol). Using unapproved gasoline may cause performance problems and/or engine damage which may not be covered under warranty.
- **Do not** use gasoline containing methanol.
- **Do not** store fuel either in the fuel tank or fuel containers over the winter unless a fuel stabilizer is used.
- **Do not** add oil to gasoline.

Important: Do not use fuel additives other than a fuel stabilizer/conditioner. Do not use fuel stabilizers with an alcohol base such as ethanol, methanol, or isopropanol.

⚠ DANGER

In certain conditions, gasoline is extremely flammable and highly explosive. A fire or explosion from gasoline can burn you and others and can damage property.

- Fill the fuel tank outdoors, in an open area, and when the engine is cold. Wipe up any gasoline that spills.
- Do not fill the fuel tank completely full. Add gasoline to the fuel tank until the level is 6 to 13 mm (1/4 to 1/2 inch) below the bottom of the filler neck. This empty space in the tank allows the gasoline to expand.
- Never smoke when handling gasoline, and stay away from an open flame or where a spark may ignite the gasoline fumes.
- Store gasoline in an approved fuel container and keep it out of the reach of children.
- Never buy more than a 30-day supply of gasoline.

⚠ DANGER

When fueling, under certain circumstances, a static charge can develop, igniting the gasoline. A fire or explosion from gasoline can burn you and others and damage property.

- **Always place gasoline containers on the ground and away from your vehicle before filling.**
- **Do not fill gasoline containers inside a vehicle or on a truck or trailer bed because interior carpets or plastic truck bed liners may insulate the container and slow the loss of any static charge.**
- **When practical, remove gasoline-powered equipment from the truck or trailer and refuel the equipment with its wheels on the ground.**
- **If this is not possible, then refuel such equipment on a truck or trailer from a portable container, not from a gasoline dispenser nozzle.**
- **If you must use a gasoline dispenser nozzle, keep the nozzle in contact with the rim of the fuel tank or container opening at all times until fueling is complete.**

Adding Fuel to the Fuel Tank

1. Clean around the fuel-tank cap (Figure 7).

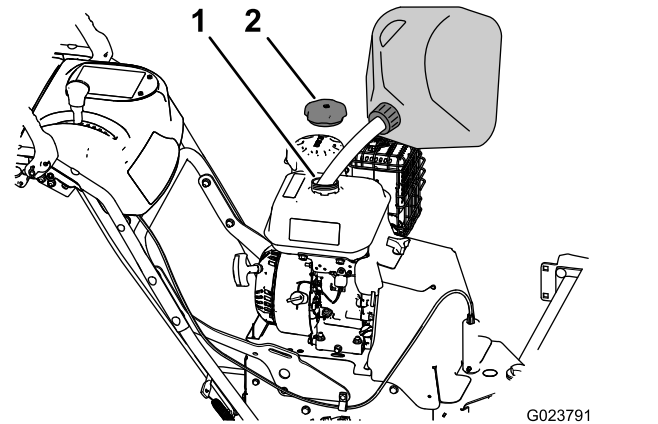

Figure 7

1. Filler neck
2. Fuel-tank cap

2. Remove the cap from the fuel tank (Figure 7).
3. Fill the fuel tank with unleaded gasoline to within 6 to 13 mm (1/4 to 1/2 inch) from the top of the tank. **Do not fill into the filler neck.**

Important: Do not fill the tank more than 6 mm (1/4 inch) from the top of the tank because the gasoline must have room to expand.

4. Install the fuel-tank cap and wipe up any spilled gasoline (Figure 7).

Operating the Engine

Positioning the Air-Cleaner Cover for Cold or Warm Air Temperature

Important: Running the engine with the air-cleaner cover positioned for cold-weather operation in normal conditions can damage the engine.

The air-cleaner cover has 2 positions: the cold or normal, ambient air positions:

Adjust the air-cleaner cover as follows:

- When operating in a **cold ambient air condition** (cold air temperature and humidity)—position the air-cleaner cover with snowflake decal facing out (Figure 8).

Note: Use this position if your machine exhibits carburetor icing. Symptoms include the engine runs rough at idle or low speed, and it discharges black or white smoke in the exhaust.

- When operating in a **normal ambient air condition**—position the air-cleaner cover with sun decal facing out (Figure 8).

Note: Use this position if your machine is not exhibiting carburetor icing.

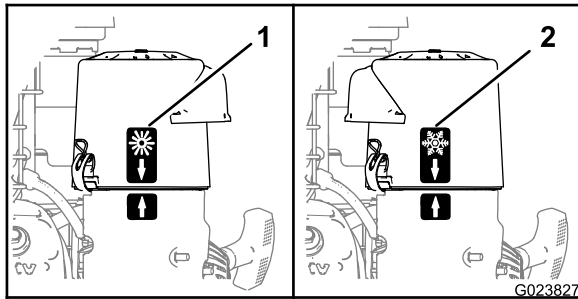

Figure 8

1. Normal ambient air position
2. Cold ambient air position

Opening the Fuel-Shutoff Valve

Move the fuel-shutoff valve located below the choke, to the right to turn on fuel (Figure 9).

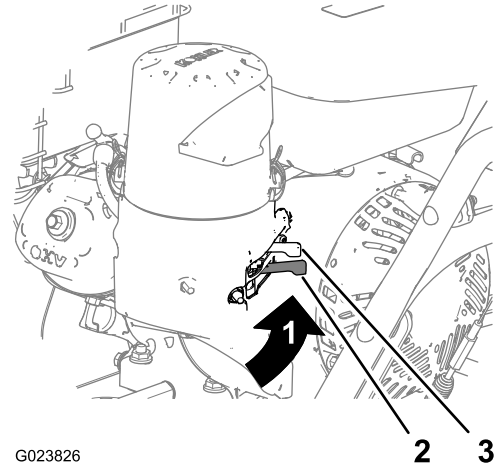

Figure 9

1. FUEL ON position
2. Fuel-shutoff valve
3. Choke

Starting the Engine

- On the right side of the engine, rotate the engine On/Off switch clockwise to the ON position (Figure 10).

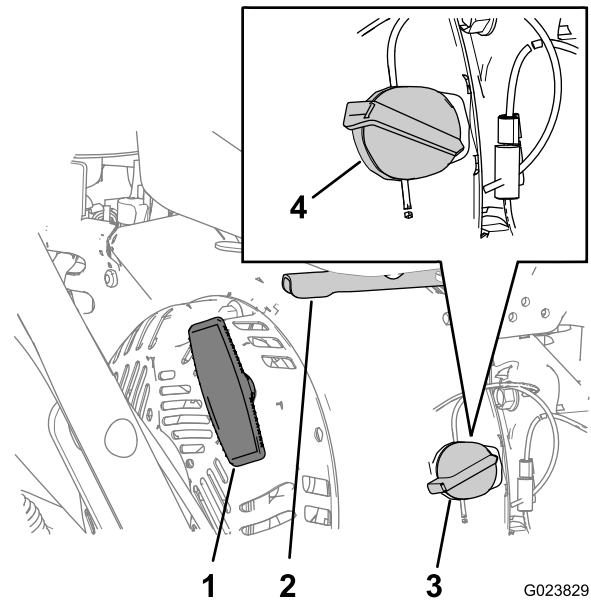

Figure 10

1. Engine-recoil handle
2. Throttle
3. Engine switch (OFF position)
4. Engine switch (ON position)

- On the rear, left side of the engine, move the choke lever to the left to the ON position. On a warm engine, leave the choke in the OFF position (Figure 9).

- Place the throttle midway between the SLOW and FAST positions located on rear, right side of the engine (Figure 10).
- Slowly pull the engine-recoil handle until you feel resistance and then stop (Figure 10).

Note: Allow the recoil handle to return and then sharply pull it straight out.

Note: Allow the rope to return slowly.

- Allow the engine to warm up for several minutes, then move the choke toward the OFF position (Figure 9).

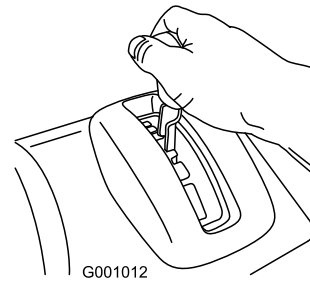

Figure 11

g001012

Stopping the Engine

- Release the broom-drive lever and the traction-drive lever.
- Place the throttle midway between the SLOW and FAST positions (Figure 10).
- Allow the engine to run for a minimum of 15 seconds, then turn the engine On/Off switch to the OFF position to stop the engine (Figure 10).
- Wait for all moving parts to stop before leaving the operating position.
- Use the fuel-shutoff valve to shut off the flow of fuel when you will not use the machine for a few days, park the machine inside a building, or transport the machine to and from the job site (Figure 9).

Note: If the ground speed is too fast, debris or snow will pile up in front of the broom causing the broom to bulldoze instead of sweep. This can damage the bristles and the drive line.

- Slowly squeeze the left traction-drive lever to the handle (Figure 12).

Note: Holding down the traction-drive lever against the handle engages the traction drive to both wheels.

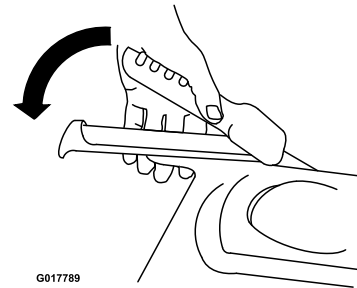

Figure 12

g017789

Driving the Machine

⚠ CAUTION

If the traction drive is not properly adjusted, the machine may move in the direction opposite of what you intended, causing injury and/or property damage.

Carefully check the traction drive and adjust it properly, if necessary.

Important: If the machine moves when the traction lever is in the released position, check the traction cable; refer to [Checking the Traction Cable \(page 23\)](#) and [Adjusting the Traction Cable \(page 23\)](#) or contact your authorized Toro dealer.

Driving Forward

- Place the speed selector lever to the desired forward position, making sure that it locks in the notch (Figure 11).

- To stop the traction drive, release the traction-drive lever.
- To move forward, engage the traction drive and slowly squeeze the left hand traction lever to the handle (Figure 13).

Note: Momentarily squeezing and releasing the left or right wheel-clutch lever allows for steering adjustments to keep the machine going in a straight line, especially in deep snow.

Note: To turn right, lift up on the right wheel-clutch lever and squeeze it toward the handle. This disengages the drive to the right wheel, while the left wheel continues driving, and the machine turns to the right.

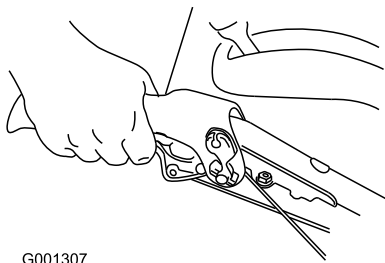

G001307

Figure 13

g001307

Note: Similarly, squeezing the left wheel-clutch lever turns the machine to the left.

Note: When you complete the turn, release the wheel-clutch lever. The drive engages both wheels (Figure 14).

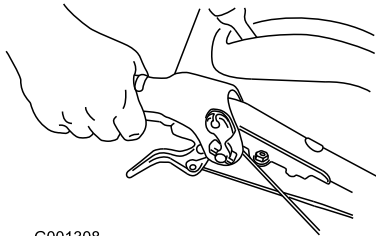

G001308

Figure 14

g001308

5. To stop the traction drive, release the traction-drive lever.

Driving the Machine Rearward

1. Place the speed-selector lever into the desired reverse-speed range, making sure that the speed selector locks in the notch.
2. To move rearward, engage the traction drive and slowly squeeze the left traction lever to the handle.

Note: Momentarily squeezing and releasing the left or right wheel-clutch lever allows for steering adjustments to keep the machine going in a straight line.

Note: To turn right, squeeze the right wheel-clutch lever toward the handle. This disengages the drive to the right wheel while the left wheel continues driving, and the machine turns to the right.

Note: Similarly, squeezing the left wheel-clutch lever turns the machine to the left.

Note: Squeezing both wheel-clutch levers simultaneously disengages the drive to both wheels. This enables you to move the machine rearward without stopping to shift it into a reverse gear. It also allows you to maneuver and transport the machine more easily when the engine is not running.

Operating the Broom

⚠ DANGER

When the machine is in operation, contact with rotating or moving parts will severely injure hands and feet.

- Before adjusting, cleaning, inspecting, troubleshooting, or repairing the machine, stop the engine and wait for all moving parts to stop. Disconnect the wire from the spark plug and keep it away from the plug to prevent someone from accidentally starting the engine.
- Stay behind the handles and away from the broom while operating the machine.
- Keep face, hands, feet, and any other part of your body or clothing away from concealed, moving, or rotating parts.

⚠ WARNING

Contact with a rotating broom can result in serious personal injury or death to the operator or bystanders.

- To remove an obstruction from the broom; refer to [Clearing a Clogged Broom \(page 16\)](#).
- Do not operate the machine if the broom drive lever is not functioning properly. Contact your authorized Toro dealer.

⚠ WARNING

The rotating broom can throw stones and other foreign objects, causing serious personal injury to the operator or to bystanders.

- Keep the working area clear and free of all objects that the broom could pick up and throw.
- Keep all children and pets away from the area of operation.

⚠ CAUTION

When the broom is engaged, it may drive the machine in the reverse direction. If the broom height is adjusted too low, the machine may move more forcefully in the reverse direction, causing injury and/or property damage.

Carefully check the broom height and adjust it properly or contact your authorized Toro dealer.

1. Set the engine throttle to the Fast position.

- Place the speed selector lever into the desired position and slowly squeeze the left hand traction drive lever.

Important: Make sure that the traction drive is engaged before operating the broom; otherwise, the broom may drive the machine in the reverse direction.

- To engage the broom, slowly squeeze the right broom lever to the handle (Figure 15).

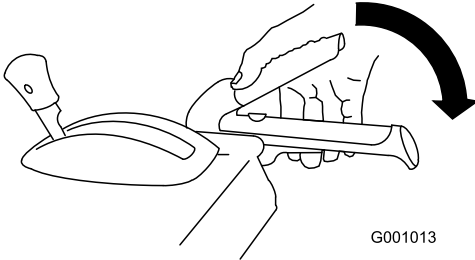

Figure 15

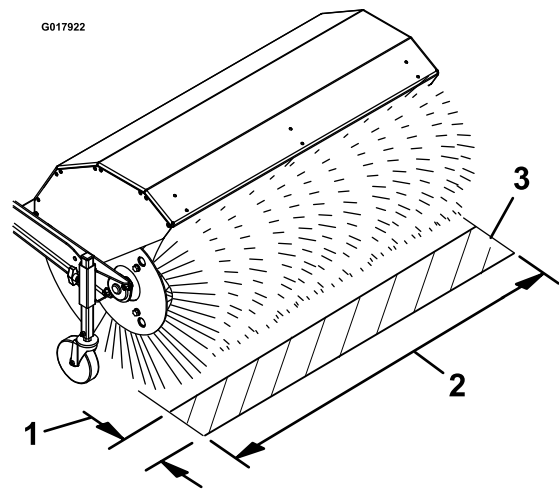

Figure 16

- 51 to 102 mm (2 to 4 inches) maximum width
- Length of broom
- Swept area

- If the engine slows down under a load or the wheels slip, shift the machine into a lower gear.
 - If the front of the machine rides up, shift the machine into a lower gear. If the front continues to ride up, lift up on the handles.
- To stop the broom, release the right lever.

- Adjust the broom height, if necessary.

Checking the Sweeping Path

A broom sweeps with the tips of its bristles. When you apply too much downward pressure, the broom no longer uses its tips; the broom is now working with the sides of the bristles. This limits the flicking action of the bristles and sweeping effectiveness, decreasing the service life of the broom.

- Drive to a flat, dusty area and stop the machine.
- With the engine running move the throttle midway between SLOW AND FAST.
- Engage the broom and allow the broom to sweep for approximately 30 seconds.
- Disengage the broom and stop the engine.
- Wait for all moving parts to stop before leaving the operating position.
- Turn the engine On/Off switch to the OFF position.
- Make sure the area swept equals the length of the broom and a maximum width of 51 to 102 mm (2 to 4 inches).

Adjusting the Broom Height

- Drive to a flat, dusty area and stop the machine.
- Disengage the broom and stop the engine.
- Wait for all moving parts to stop before leaving the operating position.
- Turn the engine On/Off switch to the OFF position.
- To adjust the broom height, remove and retain the pin from the adjuster sleeve and wheel tube of the caster (Figure 17).

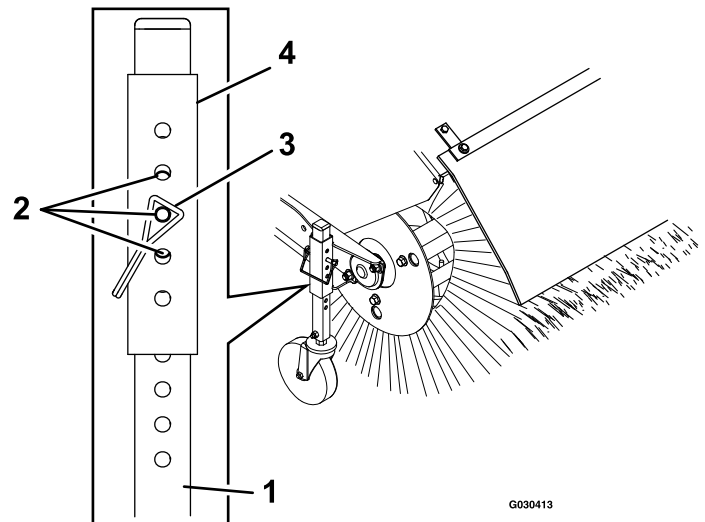

Figure 17

- Caster-wheel tube
- Positions to achieve 3 mm (1/8 inch) increments
- Pin
- Adjuster sleeve

- Raise or lower the caster wheel tube to achieve the sweep area as stated in [Checking the Sweeping Path](#) (page 15).

Note: Select any hole combination that is in alignment to place and latch the retaining pin; match the same position on the other side.

- For fine tuning adjustments, slide the adjuster sleeve 1 pin hole up or down on the caster wheel tube to adjust the broom height in 3 mm (1/8 inch) increments ([Figure 17](#)). Repeat steps 5 through 7 for the other caster wheel.
 - To raise the broom in 3 mm (1/8 inch) increments, slightly raise the adjuster sleeve and insert the pin into the next pin hole below the current hole used.
 - To lower the broom in 3 mm (1/8 inch) increments, slightly lower the adjuster sleeve and insert the pin into the next pin hole above the current hole used.
- When you attain the desired height, secure the pin on each caster wheel, and check the sweeping area.

Adjusting the Broom Side Angle

- Disengage the broom and stop the engine.
- Wait for all moving parts to stop.
- Push the lever down with the thumb of your right hand ([Figure 6](#)).
- Squeeze the left wheel-clutch lever to the handle and push the broom housing to the desired angle.

Note: The broom can rotate 19° to the right or left, or straight ahead.
- Once the broom is positioned, release the broom angle lever.
- Release the left wheel-clutch lever and make sure that the broom is locked into place.

Using the Alternate Caster Location

When working in snow, mount the casters behind the broom bristles ([Figure 18](#)).

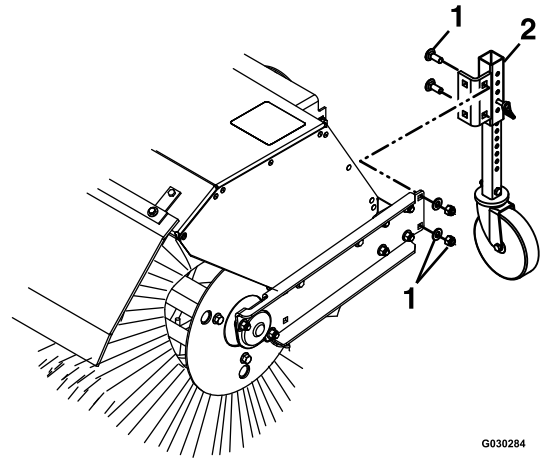

Figure 18

1. Hardware

2. Caster

Clearing a Clogged Broom

⚠ WARNING

The rotating broom could cause serious injury.

Shut off the machine and allow all rotating parts to stop before cleaning the broom.

- If the broom becomes clogged, stay in the operating position and release the left traction-drive lever. While engaging the broom, push down on the handles to raise the front of the machine a few centimeters (inches) off the pavement. Then lift the handles quickly to bump the front of the machine on the pavement. Repeat if necessary.
- If you cannot unclog the broom by bumping the front of the machine:
 - Park the machine on level ground. Stop the engine, wait for all moving parts to stop, and disconnect the spark-plug wire.
 - Sharp objects can become entangled in bristles. Use gloves and caution when removing foreign objects from the broom; do not use your hands.

Preventing Freeze-up

- In snowy and cold conditions, some controls and moving parts may freeze. Do not use excessive force when trying to operate frozen controls. If you have difficulty operating any control or part, start the engine and let it run for a few minutes.
- After using the machine, let the engine run for a few minutes to prevent moving parts from freezing. Engage the broom to clear any remaining snow from inside the housing. Stop the engine and wait for all moving parts to stop, and disconnect the spark-plug wire. Remove all ice, snow, or other debris from the machine.
- Connect the spark-plug wire. With the engine switch in the OFF position, pull the recoil-starter handle several times to prevent the recoil starter from freezing up.

Transporting the Machine

⚠ WARNING

Using ramps that are not strong enough or properly supported to load the machine onto the transport vehicle could be dangerous. The ramps could collapse, causing the machine to fall, which could cause injury.

- **Use proper ramps that are secured to the truck or trailer.**
- **Keep feet and legs out from under the machine when loading and unloading.**

Preparing to Transport the Machine

Perform the following before transporting the machine:

- Be sure that the fuel-shutoff valve is closed.
- Use a heavy-duty trailer to transport the machine. Place the machine in either a forward or reverse gear, then block the wheels.
- Securely fasten the machine to the trailer with straps, chains, cables, or ropes.
- Be sure that the trailer has all the necessary lighting and marking as required by law.

Maintenance

Note: Determine the left and right sides of the machine from the normal operating position.

Recommended Maintenance Schedule(s)

Maintenance Service Interval	Maintenance Procedure
After the first 2 hours	<ul style="list-style-type: none">• Check the traction cable.• Check the broom cable.
After the first 5 hours	<ul style="list-style-type: none">• Change the engine oil.
Before each use or daily	<ul style="list-style-type: none">• Check the engine oil level.• Check the broom-shaft shear pin.• Check for loose hardware.
Every 50 hours	<ul style="list-style-type: none">• Clean the foam pre-cleaner (more frequently in dusty conditions).• Check the tire pressure.• Check the condition of the belts.
Every 100 hours	<ul style="list-style-type: none">• Lubricate the broom-angle-lock pin.• Change the engine oil (more frequently in severe conditions).• Check the spark plug.
Every 200 hours	<ul style="list-style-type: none">• Replace the foam pre-cleaner.
Every 300 hours	<ul style="list-style-type: none">• Replace the paper air filter (more frequently in dusty conditions).
Yearly	<ul style="list-style-type: none">• Lubricate the hex shaft.• Check the traction cable.• Check the broom cable.
Yearly or before storage	<ul style="list-style-type: none">• Check the air pressure in the drive tires and inflate them to 116 to 137 kPa (17 to 20 psi).• Drain the gasoline and run the engine to dry out the fuel tank and the carburetor at the end of the season.• Have an authorized service dealer inspect and replace the traction-drive belt, if necessary.

Important: You can find more information about maintaining and servicing your machine at www.Toro.com.

Important: Refer to your engine operator's manual for additional maintenance procedures. For engine adjustments, repairs, or warranty service not covered in this manual, contact the authorized engine service dealer.

Preparing for Maintenance

1. Move the machine to a level surface.
2. Shut off the engine and allow it to cool.
3. Disconnect the spark-plug wire from the spark plug and keep the wire away from the plug, to prevent accidental starting (Figure 19).

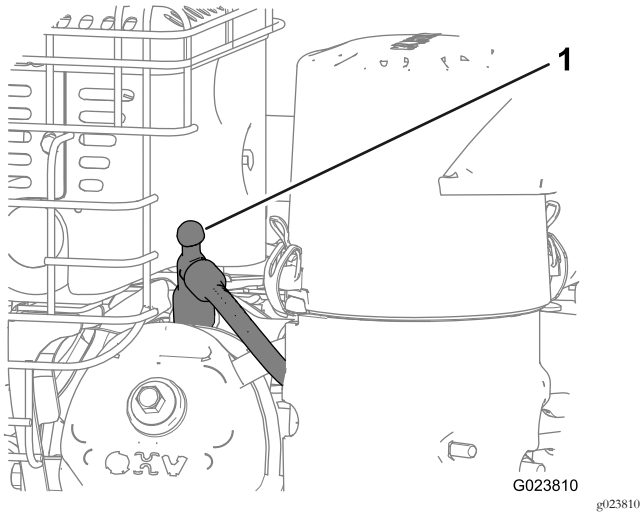

Figure 19

1. Spark-plug wire

2. Remove the belt cover and the engine shield.
3. Move the speed-selector lever to the R2 position.
4. Dip a long, clean, small-tipped paint brush in automotive engine oil and lightly lubricate the hex shaft (Figure 21).

Important: Do not get oil on the rubber wheel or the aluminum friction-drive plate as the traction drive will slip (Figure 21).

Note: Rock the machine forward and rearward to rotate the hex shaft.

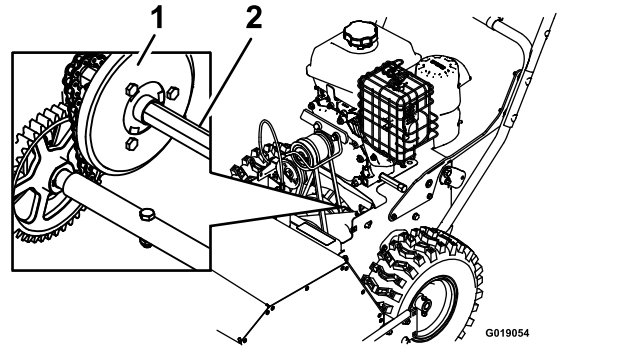

Figure 21

1. Aluminum friction-drive plate
2. Hex shaft

Lubrication

Lubricating the Broom-Angle-Lock Pin and the Hex Shaft

Service Interval: Every 100 hours

Yearly

1. Lubricate the broom-angle-lock pin fitting with No. 2 lithium grease (Figure 20).

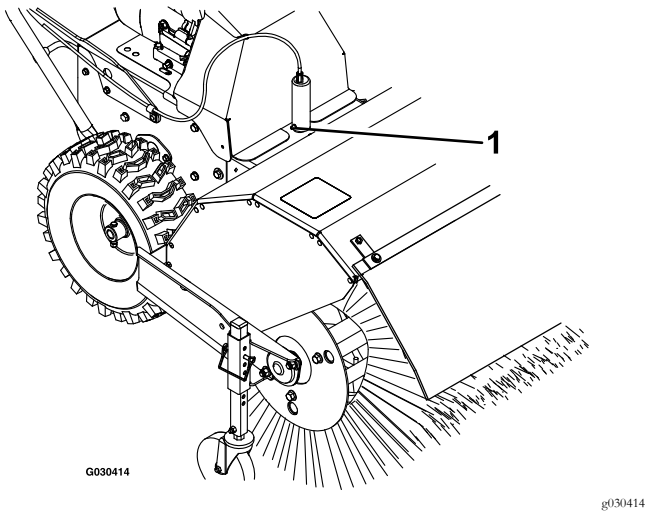

Figure 20

1. Broom-angle-lock pin

5. Move the speed selector lever to position 6.
6. Lubricate the other end of the hex shaft.
7. Move the speed selector lever forward and rearward a few times.
8. Install the belt cover and the engine shield.

Engine Maintenance

Servicing the Air Cleaner

Service Interval: Every 50 hours—Clean the foam pre-cleaner (more frequently in dusty conditions).

Every 200 hours—Replace the foam pre-cleaner.

Every 300 hours—Replace the paper air filter (more frequently in dusty conditions).

Important: Do not operate the engine without the air filter assembly; extreme engine damage may occur.

1. Release the latches on the cover for the air cleaner.
2. Remove the cover and clean it thoroughly (Figure 22).

Note: Be careful to prevent dirt and debris from falling into the base.

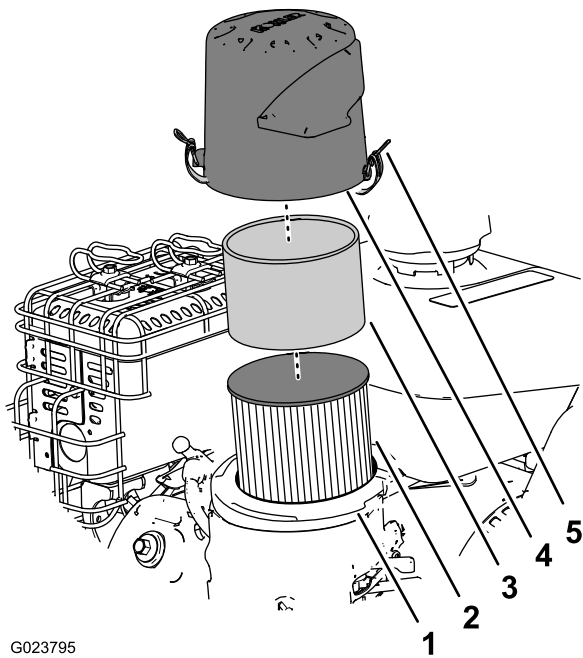

Figure 22

1. Air-filter base
2. Paper air filter
3. Foam pre-cleaner
4. Cover
5. Latch on the air-cleaner cover (2)

3. Remove the foam pre-cleaner, wash it with a mild detergent and water, and then blot it dry (Figure 22).
4. Remove and inspect the paper air filter (Figure 22); discard it if it is excessively dirty.

Important: Do not try to clean a paper filter.

5. Wipe dirt away from the base and the cover with a moist rag.

Note: Be careful to prevent dirt and debris from entering the air duct leading to the carburetor.

6. Install the foam pre-cleaner onto the paper air filter (Figure 22).

Note: Use a new paper air filter if you discarded the old one.

7. Install the air filter assembly to the air-filter base (Figure 22).
8. Align the arrow decal on the air-cleaner cover and the arrow decal on the base (Figure 23).

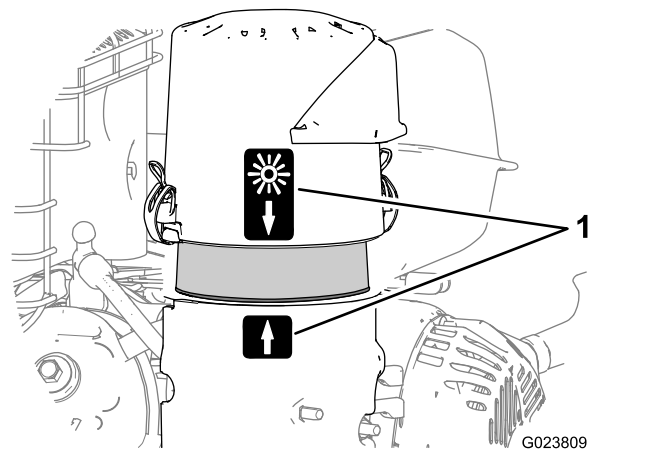

Figure 23

1. Alignment-arrow decal (normal ambient air position shown)

9. Secure the air-filter cover to the base with the latches.

Checking the Engine-Oil Level

Service Interval: Before each use or daily

Engine Oil Type: Toro 4-Cycle Premium Engine Oil

Use high-quality detergent oils (including synthetic) of API (American Petroleum Institute) service class SJ or higher. Select the viscosity based on the air temperature at time of operation as shown in the table below.

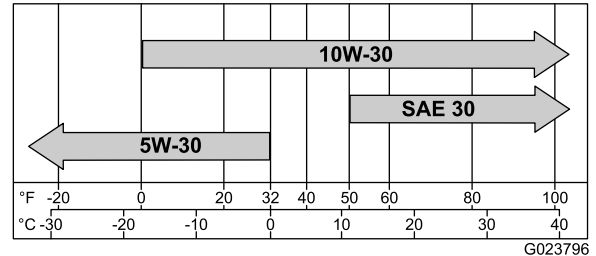

Figure 24

Check the oil level when the engine is cold.

1. Clean the area around the dipstick.
2. Remove the dipstick and read the oil level (Figure 25).

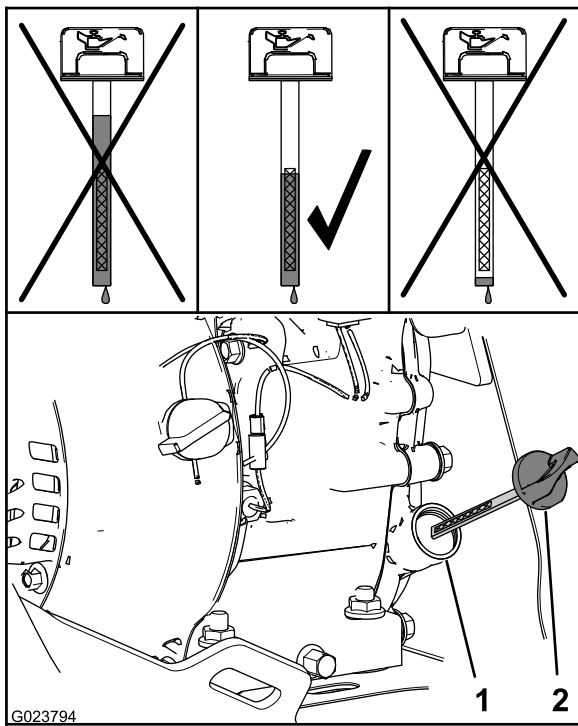

Figure 25

1. Filler neck 2. Dipstick

3. Remove the dipstick and wipe off the oil with a clean rag.
4. Insert the dipstick into the filler neck, rest it on the oil filler neck, and turn it counterclockwise until the cap drops down to lowest point of the thread leads.

Note: Do not thread the cap onto the tube.

5. Remove dipstick and check oil level.

Note: Do not operate the engine with the oil level below the Add mark or above the Full mark on the dipstick.

Note: The oil level should be at top of the indicator on the dipstick (Figure 25).

- If the oil level is low, perform the following:
 - A. Pour the specified oil into the filler neck (Figure 25).

Note: Do not overfill the engine with oil.
 - B. Repeat steps 3 through 5.
- If the oil level is high, perform the following:
 - A. Remove the cap from the drain fitting.
 - B. Drain the oil until the oil level is at the top of the indicator on dipstick; refer to steps 1 of [Changing the Engine Oil \(page 21\)](#).
 - C. Install the cap onto the drain fitting; refer to step 2 of [Changing the Engine Oil \(page 21\)](#).

6. Insert the dipstick into the filler neck and tighten the dipstick by hand.

Changing the Engine Oil

Service Interval: After the first 5 hours

Every 100 hours (more frequently in severe conditions).

Oil capacity: 0.60 L (0.63 qt)

Note: Drain the engine oil while the engine is warm.

1. Place a pan under drain fitting and remove the oil-drain cap (Figure 26).

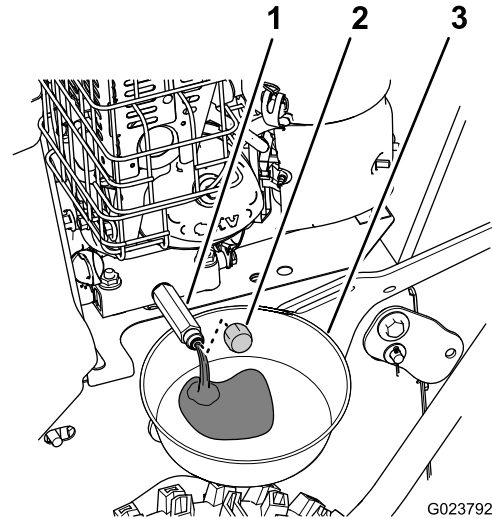

Figure 26

1. Drain fitting 3. Drain pan
2. Cap

2. Allow the oil to drain and then install the oil-drain cap.
 3. Clean around the filler neck and remove the dipstick.
 4. Fill to the specified capacity with the specified oil and replace the dipstick; refer to [Checking the Engine-Oil Level \(page 20\)](#).
- Note:** Do not overfill the engine with oil.
5. Wipe up any spilled oil.
 6. Start the engine and check for leaks.
 7. Stop the engine and check the oil level; refer to [Checking the Engine-Oil Level \(page 20\)](#).

Checking the Spark Plug

Service Interval: Every 100 hours

Spark plug type: Champion® RC12YC, Kohler® 12 132 02-S, or Kohler 25 132 14-S (RFI compliant)

Spark-plug gap: 0.76 mm (0.030 inch)

1. Disconnect the spark-plug wire from the terminal of the spark plug (Figure 19).
2. Clean the area around the base of the spark plug.
3. Remove the spark plug from the cylinder head by rotating the plug counterclockwise.
4. Examine the plug for wear and damage (Figure 27).

Important: Replace a cracked, fouled, or dirty spark plug. Do not clean the electrodes, because grit entering the cylinder can damage the engine.

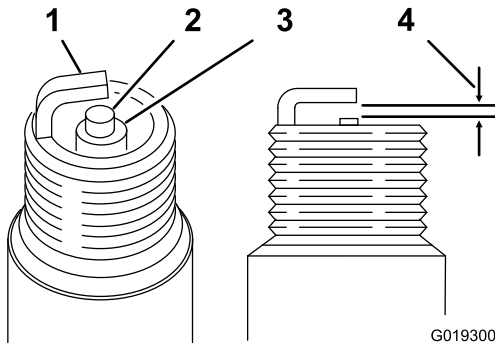

Figure 27

- | | |
|---------------------|----------------------------------------|
| 1. Ground electrode | 3. Insulator |
| 2. Center electrode | 4. Spark-plug gap 0.76 mm (0.030 inch) |

5. Check the spark-plug gap with a wire gauge (Figure 27).

Note: If necessary, adjust the gap to 0.76 mm (0.030 inch) by carefully bending the ground electrode.

6. Install the spark plug by threading it into the cylinder head and torquing the plug to 20 N-m (14 lb-ft).
7. Connect the spark-plug wire to the terminal of the spark plug.

Fuel System Maintenance

Draining the Fuel System

1. Locate the drain bolt that is in the side port of the carburetor bowl (Figure 28).

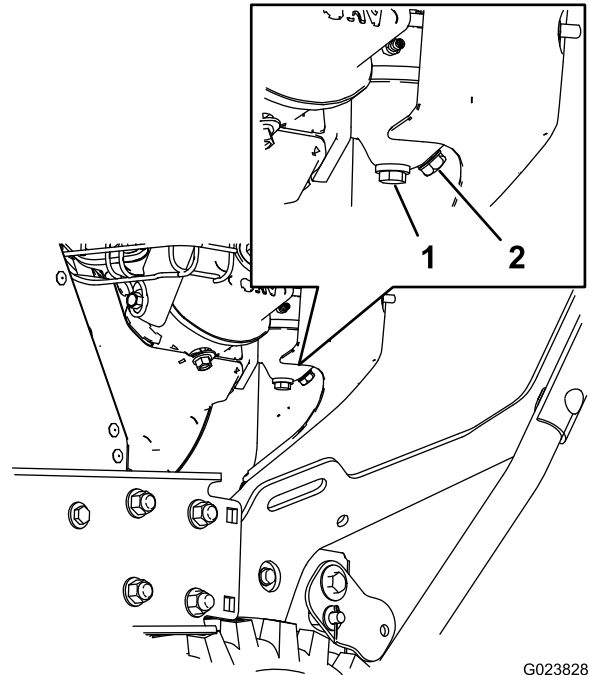

Figure 28

- | | |
|-------------------------|---------------|
| 1. Bowl-retaining screw | 2. Drain bolt |
|-------------------------|---------------|

2. Align the equipment that you will use to collect the fuel beneath the drain screw.
3. Remove the drain screw from the carburetor and allow the fuel to drain from the fuel tank and the carburetor.

Note: Do not remove the bowl-retaining screw from carburetor.

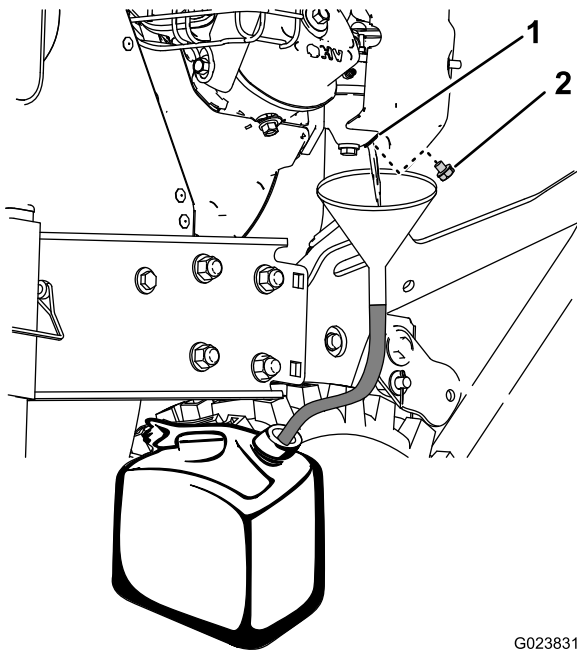

Figure 29

G023831 g023831

1. Side port of the carburetor
2. Drain bolt bowl

4. Install the drain bolt into the side port of the carburetor.

Drive System Maintenance

Checking the Tire Pressure

Service Interval: Every 50 hours

1. Turn off the engine, wait for all moving parts to stop, and leave engine switch in the OFF position.
2. Check the tire pressure in the drive tires.
3. Inflate the drive tires to 117 to 138 kPa (17 to 20 psi).

Checking the Traction Cable

Service Interval: After the first 2 hours

Yearly

1. Turn off the engine, wait for all moving parts to stop, and disconnect the spark-plug wire.
2. With the traction lever disengaged, check the pin in the elongated slot in the left side of the machine above the tire ([Figure 30](#)).

Note: There should be a gap of 6 mm (1/4 inch) from the front of the slot to the front edge of the pin ([Figure 30](#)).

Note: If adjustment is necessary, refer to [Adjusting the Traction Cable](#) (page 23).

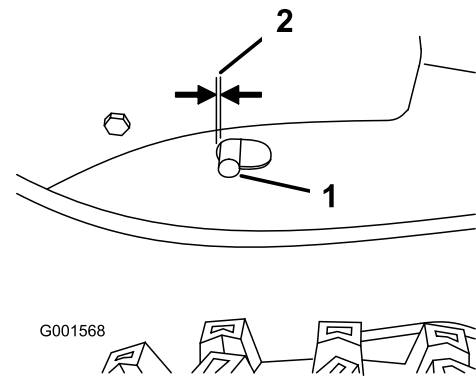

Figure 30

G001568

g001568

1. Pin
2. 6 mm (1/4 inch)

Adjusting the Traction Cable

If the machine does not drive in the forward or reverse speeds or it drives when you release the traction lever, adjust the traction cable.

With the traction lever disengaged, check the pin in the elongated slot in the left side of the machine above the tire. There should be a gap of 6 mm (1/4 inch) from the front of the slot to the front edge of the pin; refer to [Checking the Traction Cable](#) (page 23).

If the left traction cable is not properly adjusted, do the following steps:

1. Loosen the jam nut ([Figure 31](#)).
2. Loosen or tighten the turnbuckle to adjust the pin until it is the proper gap from the front edge of the slot ([Figure 31](#)).
3. Tighten the jam nut ([Figure 31](#)).

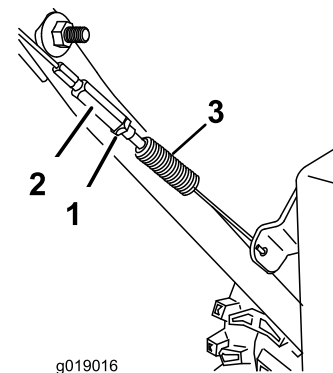

Figure 31

g019016

g019016

1. Jam nut
2. Turnbuckle

Adjusting the Wheel-Clutch Cable

1. Squeeze the lever fully, then check the gap between the bottom of the handle and the wheel-clutch lever end ([Figure 32](#)).

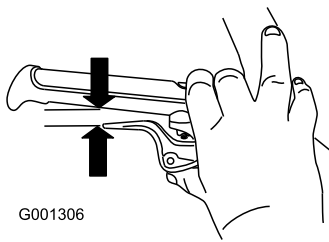

G001306

Figure 32

g001306

Note: The gap should be approximately the thickness of a pencil (6 mm or 1/4 inch). If it is greater, loosen the cable clamp nut, slide the cable jacket up slightly, tighten the cable clamp nut, and check the gap again.

2. Repeat for the other cable (Figure 32).

Broom Maintenance

Checking the Broom-Shaft Shear Pin

Service Interval: Before each use or daily

1. Move the machine to a level surface.
2. Turn off the engine, wait for all moving parts to stop, and disconnect the spark-plug wire.
3. Check the shear pin located on the broom shaft on either side of the gearbox.

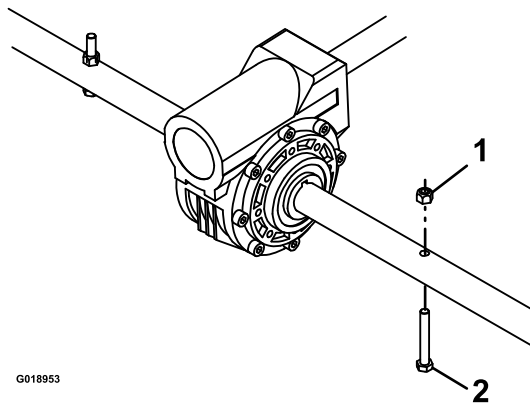

G018953

Figure 33

g019073

1. Nut
2. Shear pin

4. If the shear pin is damaged, remove the pin, replace it, and secure the it with a nut.

Replacing Worn or Damaged Broom Segments

Service Interval: As required.

1. Raise the broom by setting the caster positions.
2. On both sides of the machine, remove and retain the carriage bolts, washers, and locknuts that secure the end bearings to the broom support.

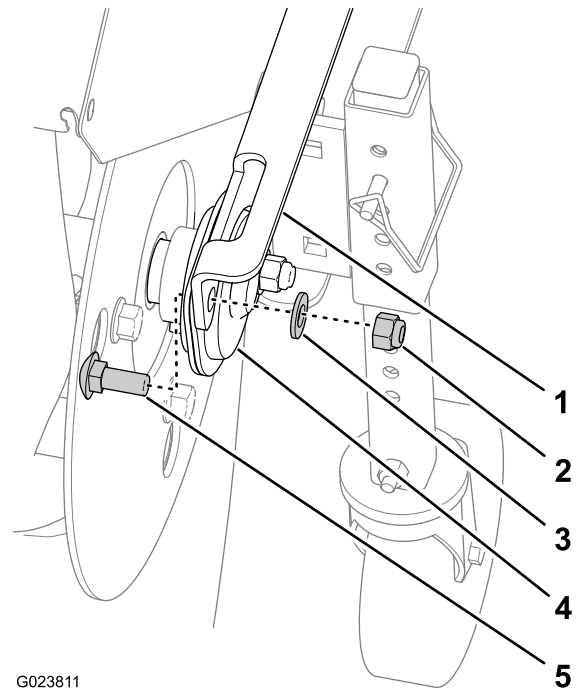

G023811

Figure 34

g023811

1. Broom support
2. Locknut
3. Washer
4. End bearing
5. Carriage bolt

3. Manually pull the power unit rearward to remove the broom assembly from the machine.
4. Support the spline shaft on either side of the gearbox.
5. Stand the broom core assembly on end so that the end retainer plate faces upward (Figure 35).

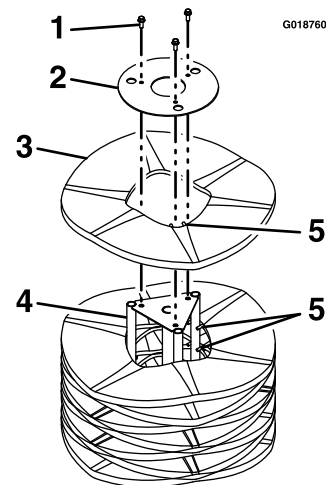

G018760

Figure 35

g018760

1. Hardware
2. End-retainer plate
3. Broom segment
4. Support shaft
5. Alignment fingers

6. Remove and retain the hardware from the end-retainer plate (Figure 35).

7. Remove the damaged broom segment(s).
8. Install the new segment(s) by staggering the metal ring alignment fingers as shown in [Figure 35](#).

Important: You may damage the broom assembly if you do not properly install the broom segments.

9. Install the broom assembly onto the machine.

Important: Make sure that the bearing setscrews are tightened before operating the broom.

Checking the Broom Cable

Service Interval: After the first 2 hours

Yearly

1. Turn off the engine, wait for all moving parts to stop, and disconnect the spark-plug wire.
2. Remove the belt cover and engine shield.
3. With the broom lever disengaged, ensure the gap between the broom-clutch assembly and the tab is 3.2 mm (1/8 inch).

Note: If the broom is not properly adjusted, refer to [Adjusting the Broom Drive](#) (page 25).

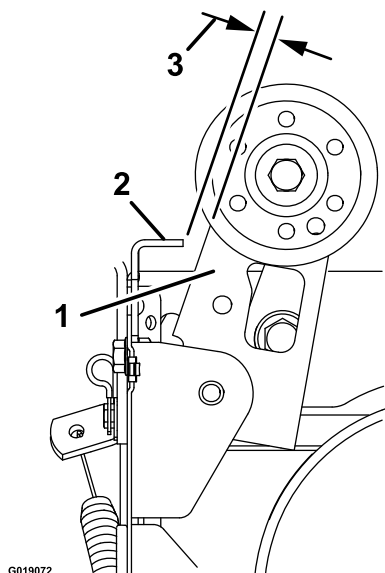

Figure 36

- | | |
|--------------------------|----------------------|
| 1. Broom-clutch assembly | 3. 3.2 mm (1/8 inch) |
| 2. Tab | |

Adjusting the Broom Drive

If the broom cable is not properly adjusted; refer to [Checking the Broom Cable](#) (page 25), and then perform the following steps:

1. Loosen the jam nut ([Figure 37](#)).

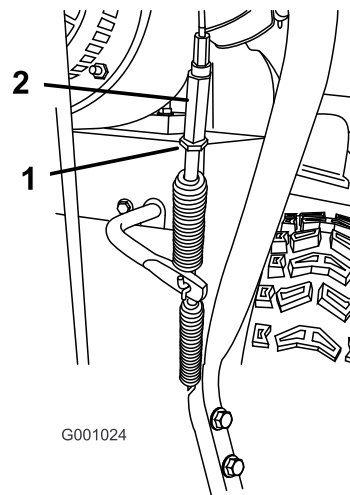

Figure 37

- | | |
|------------|---------------|
| 1. Jam nut | 2. Turnbuckle |
|------------|---------------|
-
2. Loosen or tighten the turnbuckle that adjusts the tension on the cable ([Figure 37](#)).
 3. Adjust the turnbuckle until the gap between the broom clutch assembly and the tab is 3.2 mm (1/8 inch) ([Figure 36](#)).
 4. Tighten the jam nut.
 5. If the broom cable is properly adjusted but a problem remains, contact your Authorized Toro Service Dealer.

Maintaining the Belts

Checking the Condition of the Belts

Service Interval: Every 50 hours

1. Remove the knob and washer that secures the engine cover and the belt cover to the machine (Figure 38).

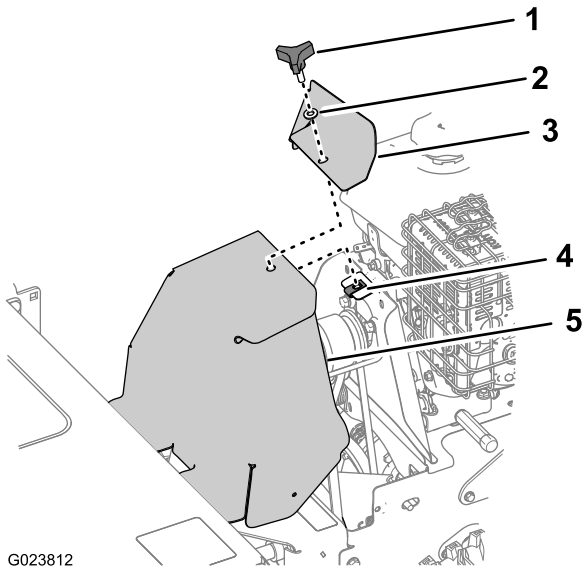

Figure 38

- | | |
|-----------------|---------------|
| 1. Knob | 4. Plate nut |
| 2. Washer | 5. Belt cover |
| 3. Engine cover | |

2. Check the 2 belts for damage or wear.

Note: Replace any damaged or excessively worn belt(s).

3. Align the belt cover and the engine cover to the machine and the plate nut (Figure 38).
4. Secure the belt cover and the engine cover to the machine with the knob and washer (Figure 38).

Removing the Broom-Drive Belt

1. Remove the engine cover and the belt cover from the machine; refer to step 1 of [Checking the Condition of the Belts](#) (page 26).
2. Remove the 2 bolts and 2 washers that secure the belt guide to the machine, and remove the belt guide and the spacer (Figure 39).

Note: The spacer is located between the engine and the pulley shield.

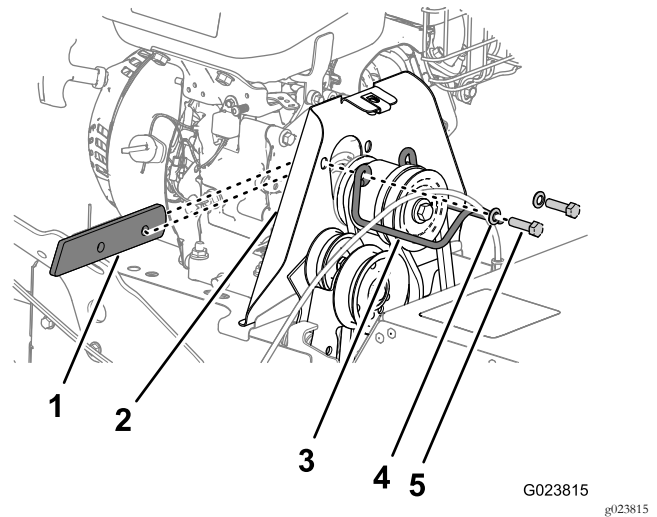

Figure 39

- | | |
|------------------|-----------|
| 1. Spacer | 4. Washer |
| 2. Pulley shield | 5. Bolt |
| 3. Belt guide | |

3. Slip the belt forward over the forward groove of the engine pulley (Figure 40).

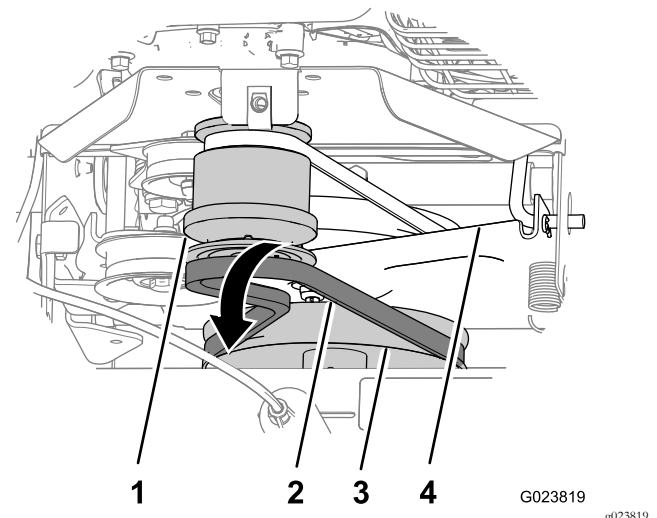

Figure 40

- | | |
|---------------------|-----------------------------|
| 1. Engine pulley | 3. Broom-gearbox pulley |
| 2. Broom drive belt | 4. Traction-control bracket |

4. Slip the belt off of the broom-gearbox pulley, move the belt rearward between the pulley and the traction-control bracket, and remove the belt from the machine (Figure 40).

Installing the Broom-Drive Belt

1. Align the replacement belt between the pulley and the traction-control bracket (Figure 40).
2. Slip the belt onto the groove at the bottom of the broom-gearbox pulley (Figure 40).

- Slip the belt onto the forward groove of the engine pulley (Figure 40).

Note: Ensure that the belt is not twisted.

- Align the spacer between the engine and the pulley shined and align the holes in the spacer, engine, and shield (Figure 39).
- Secure the pulley guide to the machine with the bolts and washers (Figure 39) that you removed in step 2 of Removing the Broom-Drive Belt (page 26).

Removing the Traction Belt

- Remove the broom-drive belt; refer to Removing the Broom-Drive Belt (page 26).
- Remove the hairpin from the traction-control rod (Figure 41).

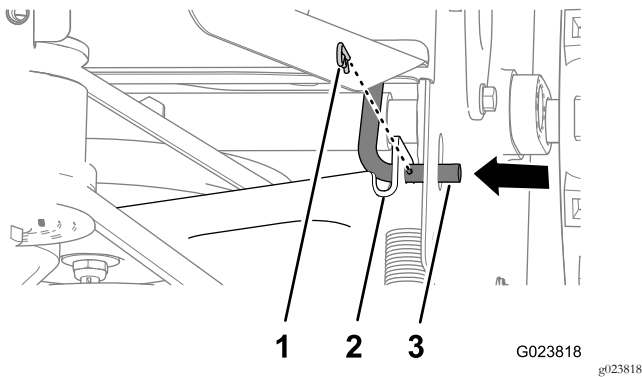

Figure 41

- Hairpin
- Traction-control rod
- Traction-control bracket

- Remove traction-control rod from the traction-control bracket by moving the rod inward (Figure 41).
- Pivot the traction-control bracket and traction pulley forward (Figure 42).

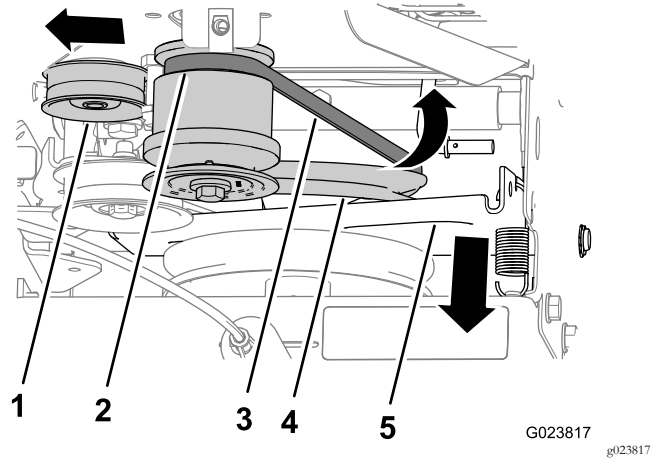

Figure 42

- Tension pulley
- Rear groove (engine pulley)
- Traction belt
- Traction pulley
- Traction-control bracket

- Pull the tension pulley outward (Figure 42).
- Slip the traction belt out of the groove of the traction pulley and up between the pulley and the friction wheel (Figure 43).

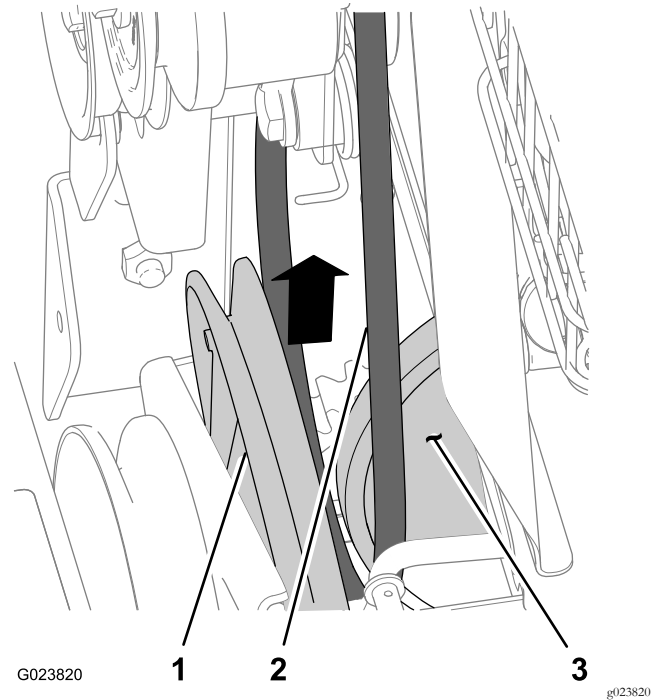

Figure 43

- Traction pulley
- Belt
- Friction wheel

- Slip the belt off the rear groove of the engine pulley and remove the belt from the machine (Figure 42).

Installing the Traction Belt

1. Align the traction belt between the friction wheel and the traction pulley (Figure 43).
2. Align the belt into the groove at the bottom of the traction pulley (Figure 42).
3. Pull the tension pulley outward (Figure 42).
4. Align the belt into the rear groove of the engine pulley (Figure 42).

Note: Release the tension pulley.

5. Move the traction-control bracket rearward and align the hole in the bracket with the traction-control rod (Figure 41).
6. Slip the rod through the bracket and secure the rod with the hairpin (Figure 41).
7. Install the broom-drive belt; refer to [Installing the Broom-Drive Belt](#) (page 26).
8. Install the engine cover and the belt cover; refer to step 1 of [Checking the Condition of the Belts](#) (page 26).

Maintaining the Chassis

Checking for Loose Hardware

Service Interval: Before each use or daily

1. Visually inspect the machine for any loose missing hardware or any other possible problem.
2. Tighten all loose hardware before operating the machine.
3. Replace all missing hardware before operating the machine.

Storage

▲ WARNING

Gasoline fumes are highly flammable, explosive, and dangerous if inhaled. If you store the machine in an area with an open flame, the gasoline fumes may ignite and cause an explosion.

- Do not store the machine in a house (living area), basement, or any other area where ignition sources may be present, such as hot water and space heaters, clothes dryers, furnaces, and other like appliances.
- Do not tip the machine backward with fuel in the tank; otherwise, fuel may leak out of the machine.

Preparing the Machine for Storage

1. Support the frame, so the bristles are not touching the ground.
Note: The bristles will become deformed and the broom will be out of alignment if the bristles are touching the ground for an extended period of time.
2. Keep the broom away from sunlight, weather, and temperature changes to prevent brittleness.
3. Thoroughly clean the broom and ensure that it is free of all caustic chemicals and/or residue.
4. On the last refueling of the year, add fuel stabilizer to fresh fuel.
5. Add the treated fuel to the machine and run the engine for 10 minutes.
6. Drain the fuel from the fuel system; refer to [Draining the Fuel System \(page 22\)](#).
7. Run the machine until the engine stops from running out of fuel.
8. Prime the engine and start it again.
9. Allow the engine to run until it stops.
10. Allow it to cool.
11. Disconnect the spark-plug wire.
12. Remove the spark plug, add 30 ml (1 oz) of engine oil through the spark-plug hole, and pull the starter rope **slowly** several times.
13. Loosely install the spark plug.
14. Dispose of any unused fuel properly. Recycle it according to local codes, or use it in your automobile.

Note: Do not store stabilized fuel for more than 90 days.

15. Clean the machine thoroughly.
16. Touch up chipped surfaces with paint available from an Authorized Toro Service Dealer. Sand affected areas before painting, and use a rust preventative to prevent the metal parts from rusting.
17. Tighten all loose screws, bolts, and locknuts. Repair or replace any damaged parts.
18. Cover the machine and store it in a clean, dry place out of the reach of children. Allow the engine to cool before storing it in any enclosure.

Removing the Machine from Storage

1. Remove the spark plug and spin the engine rapidly using the starter to blow the excess oil from the cylinder.
2. Install the spark plug by hand and then torque it to 20.4 N-m (15 ft-lb).
3. Connect the spark-plug wire.
4. Perform the annual maintenance procedures as given in the Recommended Maintenance Schedule; refer to [Maintenance \(page 18\)](#).

Troubleshooting

Problem	Possible Cause	Corrective Action
The engine does not start, starts hard, or fails to keep running.	<ol style="list-style-type: none"> 1. The fuel tank is empty. 2. The fuel-shutoff valve is closed. 3. The throttle and choke are not in the correct position. 4. There is dirt in fuel valve. 5. The fuel-cap vent is blocked. 6. Dirt, water, or stale fuel is in the fuel system. 7. The air cleaner is dirty. 8. The spark plug is faulty. 9. The spark-plug wire is not connected. 	<ol style="list-style-type: none"> 1. Fill the fuel tank. 2. Open the fuel-shutoff valve. 3. Be sure the throttle control is midway between the Slow and Fast positions, and the choke is in the On position for a cold engine or the Off position for a warm engine. 4. Clean the fuel-valve screen and cup. 5. Clean the fuel-cap vent. 6. Contact an authorized engine service dealer. 7. Clean or replace the air cleaner element. 8. Clean, adjust or replace the spark plug. 9. Check the spark-plug wire connection.
The engine loses power.	<ol style="list-style-type: none"> 1. The engine load is excessive. 2. The air cleaner is dirty. 3. The oil level in the crankcase is incorrect. 4. There is dirt in fuel tank filter. 5. Dirt, water, or stale fuel is in the fuel system. 	<ol style="list-style-type: none"> 1. Reduce the ground speed or adjust the broom. 2. Clean or replace the air cleaner element. 3. Check the oil level in the crankcase. 4. Clean the fuel-tank filter. 5. Contact an authorized engine service dealer.
The broom does not clean the surface.	<ol style="list-style-type: none"> 1. The broom height is incorrect . 2. The tire pressure in the drive tires is not correct. 3. You are cleaning too much debris at one time. 	<ol style="list-style-type: none"> 1. Adjust the broom height. 2. Adjust the tire pressure in the drive tires. 3. Slow down and clear smaller areas of debris.
The broom does not rotate.	<ol style="list-style-type: none"> 1. The broom is clogged. 2. The broom drive lever is not engaged. 3. The broom drive belt is slipping. 4. The belt is broken. 5. The shear pin is broken. 	<ol style="list-style-type: none"> 1. Unclog the broom. 2. Engage the broom drive lever. 3. Adjust or replace the belt. 4. Replace the belt. 5. Replace the shear pin.
The machine pulls left or right.	<ol style="list-style-type: none"> 1. The tire pressure in the drive tires is not correct. 	<ol style="list-style-type: none"> 1. Adjust the tire pressure in the drive tires.
The machine does not drive.	<ol style="list-style-type: none"> 1. The drive belt is worn, loose or broken. 2. The drive belt is off a pulley. 	<ol style="list-style-type: none"> 1. Install a new belt. 2. Replace or adjust the belt.
There is abnormal vibration.	<ol style="list-style-type: none"> 1. The broom assembly is loose or damaged. 2. The engine mounting bolts are loose. 3. The engine pulley or idler pulley is loose. 4. The engine pulley is damaged. 5. The belt is damaged. 	<ol style="list-style-type: none"> 1. Tighten the hardware, replace the broom assembly, or contact an Authorized Toro Service dealer. 2. Tighten the engine-mounting bolts. 3. Tighten the appropriate pulley. 4. Contact an Authorized Toro Service dealer. 5. Install a new belt.
The broom does not stop when the drive lever is released.	<ol style="list-style-type: none"> 1. The broom-drive belt is out of adjustment. 	<ol style="list-style-type: none"> 1. Check the broom-drive adjustment.

Problem	Possible Cause	Corrective Action
The broom wears out prematurely.	1. You are using the incorrect broom height.	1. Adjust the broom height.
The speed selector is difficult to move or frozen in place.	1. The hex shaft needs lubrication.	1. Lubricate the hex shaft.

Notes:

Notes:

Notes:

European Privacy Notice

The Information Toro Collects

Toro Warranty Company (Toro) respects your privacy. In order to process your warranty claim and contact you in the event of a product recall, we ask you to share certain personal information with us, either directly or through your local Toro company or dealer.

The Toro warranty system is hosted on servers located within the United States where privacy law may not provide the same protection as applies in your country.

BY SHARING YOUR PERSONAL INFORMATION WITH US, YOU ARE CONSENTING TO THE PROCESSING OF YOUR PERSONAL INFORMATION AS DESCRIBED IN THIS PRIVACY NOTICE.

The Way Toro Uses Information

Toro may use your personal information to process warranty claims, to contact you in the event of a product recall and for any other purpose which we tell you about. Toro may share your information with Toro's affiliates, dealers or other business partners in connection with any of these activities. We will not sell your personal information to any other company. We reserve the right to disclose personal information in order to comply with applicable laws and with requests by the appropriate authorities, to operate our systems properly or for our own protection or that of other users.

Retention of your Personal Information

We will keep your personal information as long as we need it for the purposes for which it was originally collected or for other legitimate purposes (such as regulatory compliance), or as required by applicable law.

Toro's Commitment to Security of Your Personal Information

We take reasonable precautions in order to protect the security of your personal information. We also take steps to maintain the accuracy and current status of personal information.

Access and Correction of your Personal Information

If you would like to review or correct your personal information, please contact us by email at legal@toro.com.

Australian Consumer Law

Australian customers will find details relating to the Australian Consumer Law either inside the box or at your local Toro Dealer.



The Toro Warranty

A limited warranty (see warranty periods below)

Turf Renovation

Conditions and Products Covered

The Toro Company and its affiliate, Toro Warranty Company, pursuant to an agreement between them, jointly warrant your Toro Products listed below to be free from defects in materials or workmanship.

This warranty covers the cost of parts and labor, but you must pay transportation costs.

The following time periods apply from the original date of purchase:

Products	Warranty Period
Walk-Behind Aerator	1 year
• Engine ¹	2 years
Stand-On Aerator	1 year
• Battery	90 days Parts and Labor
	1 year Parts Only
• Engine ¹	2 years
Dethatcher	1 year
• Engine ¹	2 years
Turf Seeder	1 year
• Engine ¹	Honda – 2 years
	Subaru – 5 years
Stand-On Spreader Sprayer	1 year
• Battery	90 days Parts and Labor
	1 year Parts Only
• Engine ¹	5 years
Walk-Behind Rotary Broom	1 year
• Engine ¹	2 years
Brush Cutter	1 year
• Engine ¹	2 years

Where a warrantable condition exists, we will repair the Product at no cost to you including diagnosis, labor, and parts.

¹ Some engines used on Toro Products are warranted by the engine manufacturer.

Instructions for Obtaining Warranty Service

If you think that your Toro Product contains a defect in materials or workmanship, follow this procedure^{**}:

1. Contact any Authorized Servicing Outlet to arrange service at their dealership. To locate one convenient to you, access our website at www.Toro.com. Select "Where to Buy" and select "Contractor" under product type. You may also call our toll free number below.
2. Bring the product and your proof of purchase (sales receipt) to them.
3. If for any reason you are dissatisfied with the Service Outlet's analysis or with the assistance provided, contact us at:

Toro Warranty Company
8111 Lyndale Avenue South
Bloomington, MN 55420-1196
Toll Free: 888-384-9939

^{**}Toro Authorized Rental Customers who have purchased products directly from Toro and have signed the Toro Rental Customer Agreement have the ability to perform their own warranty work. Please visit Toro's Rental Portal for electronic warranty claim filing procedures or call the toll free number above.

Owner Responsibilities

You must maintain your Toro Product by following the maintenance procedures described in the *Operator's Manual*. Such routine maintenance,

whether performed by a dealer or by you, is at your expense. Parts scheduled for replacement as required maintenance ("Maintenance Parts"), are warranted for the period of time up to the scheduled replacement time for that part. Failure to perform required maintenance and adjustments can be grounds for disallowing a warranty claim.

Items and Conditions Not Covered

Not all product failures or malfunctions that occur during the warranty period are defects in materials or workmanship. This express warranty does not cover the following:

- Product failures which result from installation and use of add-on, modified, or unapproved accessories
- Failure to perform required maintenance and/or adjustments
- Repairs necessary due to failure to follow recommended fuel procedure (consult *Operator's Manual* for more details)
 - Removing contaminants from the fuel system is not covered
 - Use of old fuel (more than one month old) or fuel which contains more than 10% ethanol or more than 15% MTBE
 - Failure to drain the fuel system prior to any period of non-use over one month
- Product failures which result from operating the product in an abusive, negligent, or reckless manner
- Parts subject to consumption through use unless found to be defective. Examples of parts which are consumed, include, belts, cutters, clutches, blades, teeth, spark plugs, tires, filters, etc.
- Failures caused by outside influence include, weather, storage, contamination, lubricants, additives, or chemicals, etc.
- Normal "wear and tear" items includes painted surfaces and scratched decals, etc.
- Any component covered by a separate manufacturer's warranty
- Pickup and delivery charges

General Conditions

Repair by an Authorized Servicing Outlet or Self-Service as an Authorized Rental Customer is your sole remedy under the warranty.

Neither The Toro Company nor Toro Warranty Company is liable for indirect, incidental or consequential damages in connection with the use of the Toro Products covered by this warranty, including any cost or expense of providing substitute equipment or service during reasonable periods of malfunction or non-use pending completion of repairs under this warranty. All implied warranties of merchantability and fitness for use are limited to the duration of this express warranty. Some states do not allow exclusions of incidental or consequential damages, or limitations on how long an implied warranty lasts, so the above exclusions and limitations may not apply to you.

This warranty gives you specific legal rights, and you may also have other rights which vary from state to state.

Except for the engine warranty coverage and the Emissions warranty referenced below, if applicable, there is no other express warranty. The Emissions Control System on your Product may be covered by a separate warranty meeting requirements established by the U.S. Environmental Protection Agency (EPA) or the California Air Resources Board (CARB). Refer to the California Emission Control Warranty Statement supplied with your Product or contained in the engine manufacturer's documentation for details.

Countries Other than the United States or Canada

Customers who have purchased Toro products outside the United States or Canada should contact their Toro Distributor (Dealer) to obtain guarantee policies for your country, province, or state. If for any reason you are dissatisfied with your Distributor's service or have difficulty obtaining guarantee information, contact the Toro importer. If all other remedies fail, you may contact us at Toro Warranty Company.

Australian Consumer Law: Australian customers will find details relating to the Australian Consumer Law either inside the box or at your local Toro Dealer.