



Count on it.

Operator's Manual

Reelmaster® 3100-D Traction Unit

Model No. 03170—Serial No. 40000000 and Up

Model No. 03171—Serial No. 40000000 and Up



This product complies with all relevant European directives; for details, please see the separate product specific Declaration of Conformity (DOC) sheet.

▲ WARNING

**CALIFORNIA
Proposition 65 Warning**

This product contains a chemical or chemicals known to the State of California to cause cancer, birth defects, or reproductive harm.

Diesel engine exhaust and some of its constituents are known to the State of California to cause cancer, birth defects, and other reproductive harm.

It is a violation of California Public Resource Code Section 4442 or 4443 to use or operate the engine on any forest-covered, brush-covered, or grass-covered land unless the engine is equipped with a spark arrester, as defined in Section 4442, maintained in effective working order or the engine is constructed, equipped, and maintained for the prevention of fire.

This spark ignition system complies with Canadian ICES-002

The enclosed engine owner's manual is supplied for information regarding the US Environmental Protection Agency (EPA) and the California Emission Control Regulation of emission systems, maintenance, and warranty. Replacements may be ordered through the engine manufacturer.

Introduction

This machine is a ride-on, reel-blade lawn mower intended to be used by professional operators in commercial applications. It is designed primarily for cutting grass on well-maintained lawns in parks, golf courses, sports fields, and on commercial grounds. It is not designed for cutting brush, mowing grass and other growth alongside highways, or for agricultural uses.

Read this information carefully to learn how to operate and maintain your product properly and to avoid injury and product damage. You are responsible for operating the product properly and safely.

You may contact Toro directly at www.Toro.com for product and accessory information, help finding a dealer, or to register your product.

Whenever you need service, genuine Toro parts, or additional information, contact an Authorized Service Dealer or Toro Customer Service and have the model and serial numbers of your product ready. [Figure 1](#) identifies the location of the

model and serial numbers on the product. Write the numbers in the space provided.

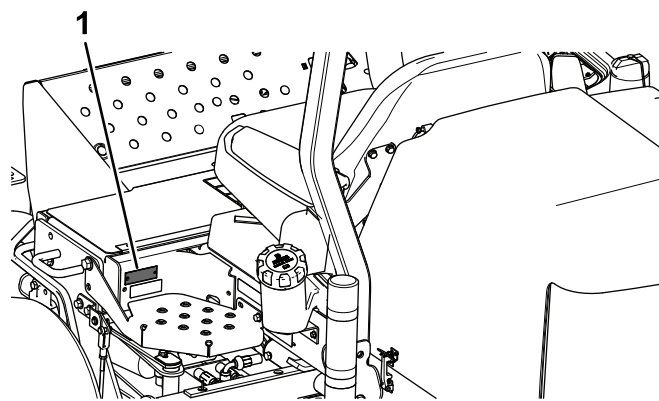

Figure 1

1. Model and serial number location

Model No. _____

Serial No. _____

This manual identifies potential hazards and has safety messages identified by the safety-alert symbol ([Figure 2](#)), which signals a hazard that may cause serious injury or death if you do not follow the recommended precautions.



Figure 2

1. Safety-alert symbol

This manual uses 2 words to highlight information.

Important calls attention to special mechanical information and **Note** emphasizes general information worthy of special attention.

Contents

Safety	4	Servicing the Fuel Tank	50
General Safety.....	4	Inspecting the Fuel Lines and Connections.....	50
Safe Operating Practices.....	4	Draining the Water Separator	50
Toro Riding Mower Safety	6	Changing the Fuel Filter Canister.....	50
Safety and Instructional Decals	7	Bleeding Air from the Injectors	50
Setup	14	Electrical System Maintenance	51
1 Installing the Wheels	15	Caring for the Battery.....	51
2 Installing the Steering Wheel.....	15	Storing the Battery.....	52
3 Activating, Charging, and Connecting the Battery	15	Checking the Fuses.....	52
4 Checking the Angle Indicator.....	17	Drive System Maintenance	52
5 Installing the CE Decal.....	17	Adjusting the Traction Drive for Neutral.....	52
6 Installing the Hood Latch (CE Only).....	17	Cooling System Maintenance	53
7 Installing the Exhaust Guard (CE Only)	19	Cleaning the Engine Cooling System	53
8 Installing the Roll Bar	19	Brake Maintenance	53
9 Installing the Front Lift Arms	20	Adjusting the Parking Brake.....	53
10 Installing the Carrier Frames to the Cutting Units.....	21	Belt Maintenance	54
11 Mounting the Cutting Units	22	Servicing the Engine Belts	54
12 Mounting the Cutting Unit Drive Motors	23	Controls System Maintenance	55
13 Adjusting the Lift Arms	24	Adjusting the Throttle.....	55
14 Installing the Tipper Roller Kit (Optional).....	25	Hydraulic System Maintenance	55
Product Overview	26	Changing the Hydraulic Fluid.....	55
Controls	26	Changing the Hydraulic Filter.....	56
Specifications	28	Checking the Hydraulic Lines and Hoses.....	56
Attachments/Accessories.....	28	Miscellaneous Maintenance	57
Operation	29	Backlapping the Cutting Units.....	57
Think Safety First.....	29	Storage	58
Checking the Engine-Oil Level.....	29	Preparation for Seasonal Storage	58
Filling the Fuel Tank	30		
Checking the Cooling System.....	30		
Checking the Hydraulic System	31		
Checking the Tire Pressure	32		
Checking the Reel-to-Backknife Contact	32		
Torquing the Wheel Nuts	32		
Starting and Shutting Off the Engine.....	32		
Bleeding the Fuel System.....	33		
Checking the Interlock System	34		
Identifying the Tie-Down Points	34		
Hauling the Machine.....	34		
Towing the Machine	34		
Using the Standard Control Module (SCM)	34		
Operating Tips	37		
Maintenance	42		
Recommended Maintenance Schedule(s)	42		
Daily Maintenance Checklist.....	43		
Service Interval Chart	44		
Pre-Maintenance Procedures	45		
Removing the Hood	45		
Lubrication	45		
Greasing the Bearings And Bushings.....	45		
Checking the Sealed Bearings	48		
Engine Maintenance	48		
Servicing the Air Cleaner.....	48		
Changing the Engine Oil and the Filter	49		
Fuel System Maintenance	50		

Safety

This machine has been designed in accordance with EN ISO 5395:2013 and ANSI B71.4-2012.

General Safety

This product is capable of amputating hands and feet and of throwing objects. Always follow all safety instructions to avoid serious personal injury.

Using this product for purposes other than its intended use could prove dangerous to you and bystanders.

- Read and understand the contents of this *Operator's Manual* before starting the engine.
- Do not put your hands or feet near moving components of the machine.
- Do not operate the machine without all guards and other safety protective devices in place and working on the machine.
- Keep clear of any discharge opening. Keep bystanders and pets a safe distance away from the machine.
- Keep children out of the operating area. Never allow children to operate the machine.
- Stop the machine and shut off the engine before servicing, fueling, or unclogging the machine.
- Avoid sudden starts and stops, holes, dropoffs, and hidden hazards in the terrain.
- For braking, move the traction pedal to the neutral position or to the direction opposite the travel direction.

Improperly using or maintaining this machine can result in injury. To reduce the potential for injury, comply with these safety instructions and always pay attention to the safety-alert symbol, which means Caution, Warning, or Danger—personal safety instruction. Failure to comply with these instructions may result in personal injury or death.

You can find additional safety information where needed throughout this *Operator's Manual*.

Safe Operating Practices

- Never allow children or people unfamiliar with these instructions to use or service the mower. Local regulations may restrict the age of the operator.
- Never mow while people, especially children, or pets are nearby.
- Become familiar with the safe operation of the equipment, operator's controls, and safety signs.
- Do not carry passengers.
- All drivers and mechanics should seek and obtain professional and practical instruction. The owner is responsible for training the users. Such instruction should

emphasize the need for care and concentration when working with ride-on machines.

- The owner/user can prevent and is responsible for accidents or injuries occurring to people or damage to property.

Preparation

- While mowing, always wear substantial, slip-resistant footwear, long pants, safety glasses, and ear protection.
- Thoroughly inspect the area where the equipment is to be used and remove all objects which may be thrown by the machine.
- Evaluate the terrain to determine what accessories and attachments are needed to properly and safely perform the job. Only use accessories and attachments approved by the manufacturer.
- Check that the operator's presence controls, safety switches, and shields are attached and functioning properly. Do not operate the machine unless they are functioning properly.

Safe Handling of Fuels

- To avoid personal injury or property damage, use extreme care in handling fuel. Fuel is extremely flammable and the vapors are explosive.
- Extinguish all cigarettes, cigars, pipes, and other sources of ignition.
- Use only an approved fuel container.
- Never remove the fuel cap or add fuel with the engine running.
- Allow engine to cool before refueling.
- Never refuel the machine indoors.
- Never store the machine or fuel container where there is an open flame, spark, or pilot light, such as on a water heater or on other appliances.
- Never fill containers inside a vehicle or on a truck or trailer bed with a plastic liner. Always place containers on the ground, away from your vehicle before filling.
- Remove equipment from the truck or trailer and refuel it on the ground. If this is not possible, then refuel such equipment with a portable container rather than from a fuel-dispenser nozzle.
- Keep the nozzle in contact with the rim of the fuel tank or container opening at all times until fueling is complete. Do not use a nozzle lock-open device.
- If fuel is spilled on clothing, change clothing immediately.
- Never overfill fuel tank. Replace the fuel cap and tighten it securely.

Operation

- Do not operate the engine in a confined space.
- Mow only in daylight or in good artificial light.

- Before attempting to start the engine, disengage all blade attachment clutches, shift into neutral, and engage the parking brake.
- Stay alert for holes in the terrain and other hidden hazards.
- Watch out for traffic when crossing or near roadways.
- Stop the blades rotating before crossing surfaces other than grass.
- Never operate the machine with damaged guards, shields, or without safety protective devices in place. Make sure that all interlocks are attached, adjusted properly, and functioning properly.
- Do not change the engine governor settings or overspeed the engine. Operating the engine at excessive speed may increase the hazard of personal injury.
- Before leaving the operator's position, do the following:
 - Park the machine on level ground.
 - Shut off and lower the cutting units.
 - Engage the parking brake.
 - Shut off the engine and remove the key.
- Disengage drive to attachments when transporting or not in use.
- Shut off the engine and disengage drive to attachment for the following:
 - Before refuelling
 - Before removing the grass catcher/catchers
 - Before making a height adjustment unless you can make the adjustment from the operator's position
 - Before clearing blockages
 - Before checking, cleaning or working on the mower
 - After striking a foreign object or if an abnormal vibration occurs. Inspect the mower for damage and make repairs before restarting and operating the equipment
- Reduce the engine speed setting during engine run-out.
- Keep your hands and feet away from the cutting units.
- Look behind and down before backing up to be sure of a clear path.
- Slow down and use caution when making turns and crossing roads and sidewalks. Stop the cutting units if not mowing.
- Do not operate the mower if tired, ill, or under the influence of alcohol or drugs.
- Lightning can cause severe injury or death. If lightning is seen in the area, do not operate the machine; seek shelter.
- Use care when loading or unloading the machine into a trailer or truck.
- Use care when approaching blind corners, shrubs, trees, or other objects that may obscure vision.

Rollover Protection System (ROPS) Safety

- **Do not** remove the ROPS from the machine.
- Ensure that the seat belt is attached and that you can release it quickly in an emergency.
- Always wear your seat belt if your machine has a fixed roll bar.
- Check carefully for overhead obstructions and do not contact them.
- Keep the ROPS in safe operating condition by thoroughly inspecting it periodically for damage and keeping all the mounting fasteners tight.
- Replace a damaged ROPS. Do not repair or alter it.

Slope Safety

- This triplex mower has a unique drive system for superior traction on hills.
- The uphill wheel does not spin out and limit traction like conventional triplex mowers.
- If you operate the machine on a side hill that is too steep, rollover will occur before losing traction.
- Use extreme caution on hills, slopes, and rough terrain.
 - Do not operate on any side hill until your supervisor has completed a site survey as outlined in the *Operator's Manual*.
 - When possible, mow up and down a hill, rather than across it. Do not turn on hills.
 - Operator must be skilled and trained in slope operation.
 - Avoid wet or loose turf conditions that may cause the machine to slide.
 - On side hills, shift the cutting units uphill (if so equipped).
- Slow down the machine and use extra care on hillsides. Travel in the recommended direction on hillsides. Turf conditions can affect the stability of the machine.
- Avoid starting, stopping, or turning the machine on a slope. If the tires lose traction, disengage the blade(s) and proceed slowly straight down the slope.
- Do not turn the machine sharply. Use care when reversing the machine.
- When operating the machine on a slope, always keep all cutting units lowered.
- Avoid turning the machine on slopes. If you must turn, turn slowly and gradually downhill, if possible.
- Use extra care while operating the machine with attachments; they can affect the stability of the machine. Follow the recommendations for using the machine on a slope in this *Operator's Manual*.
- Remember that there is no such thing as a safe slope. Travel on grass slopes requires particular care. Do the following to guard against overturning:

- Do not stop or start suddenly when going up or downhill.
- Keep machine speeds low on slopes and during tight turns.
- Stay alert for humps and hollows and other hidden hazards.
- Never mow across the face of the slope, unless the mower is designed for this purpose.
- You cannot regain control of a ride-on machine by applying the brake. The main reasons for loss of control are as follows:
 - Insufficient wheel grip
 - Being driven too fast
 - Inadequate braking
 - The type of machine is unsuitable for the task
 - Lack of awareness of the effect of ground conditions, especially slopes
 - Incorrect hitching and load distribution

Maintenance and Storage

- Keep all nuts, bolts and screws tight to be sure that the equipment is in safe working condition.
- Never store the equipment with fuel in the tank inside a building, where fumes may reach an open flame or spark.
- Allow the engine to cool before storing in any enclosure.
- To reduce the fire hazard, keep the engine, silencer/muffler, battery compartment and fuel storage area free of grass, leaves, or excessive grease.
- Check the grass catcher frequently for wear or deterioration.
- Keep all parts in good working condition and all hardware and hydraulic fittings tightened. Replace all worn or damaged parts and decals.
- If the fuel tank must be drained, do this outdoors.
- Be careful during adjustment of the machine to prevent entrapment of the fingers between moving blades and fixed parts of the machine.
- On multi-cylinder/multi-reel machines, take care as rotating one cylinder/reel can cause other cylinders/reels to rotate.
- Disengage drives, lower the cutting units, engage the parking brake, shut off the engine, and remove the key from the ignition. Wait for all movement to stop before adjusting, cleaning, or repairing the machine.
- Clean grass and debris from cutting units, drives, silencers/mufflers, and engine to help prevent fires. Clean up oil or fuel spills.
- Use jack stands to support components when required.
- Carefully release pressure from components with stored energy.

- Disconnect battery before making any repairs. Disconnect the negative terminal first and the positive last. Connect positive first and negative last.
- Use care when checking the cylinders/reels. Wear gloves and use caution when servicing them.
- Keep your hands and feet away from moving parts. If possible, do not make adjustments with the engine running.
- Charge batteries in an open, well-ventilated area, away from spark and flames. Unplug the charger before connecting or disconnecting from battery. Wear protective clothing and use insulated tools.

Hauling

- Use care when loading or unloading the machine into a trailer or truck.
- Use full-width ramps for loading machine into trailer or truck.
- Tie the machine down securely using straps, chains, cable, or ropes. Both front and rear straps should be directed down and outward from the machine.

Toro Riding Mower Safety

The following list contains safety information specific to Toro products or other safety information that you must know that is not included in the CEN, ISO, or ANSI standard.

This product is capable of amputating hands and feet and of throwing objects. Always follow all safety instructions to avoid serious injury or death.

Use of this product for purposes other than its intended use could prove dangerous to you and bystanders.

⚠ DANGER

Engine exhaust contains carbon monoxide, which is an odorless, deadly poison that can kill you.

Do not operate the engine in a confined space, where dangerous carbon monoxide and other exhaust gasses can collect.

- Know how to shut off the engine quickly.
- Wear substantial slip-resistant footwear and long pants. Tie back long hair and do not wear jewelry.
- Handle fuel carefully. Wipe up any spills.
- Check the safety-interlock switches daily for proper operation. If a switch should fail, replace the switch before operating the machine.
- Before starting the engine, sit on the seat.
- Using the machine demands attention. To prevent loss of control:

- Reduce speed when making sharp turns. Avoid sudden stops and starts.
- When near or crossing roads, always yield the right-of-way.
- When operating a machine with ROPS (rollover-protection system), never remove the roll bar and always use the seat belt.
- Raise the cutting units when driving from one work area to another.
- Do not touch the engine, silencer/muffler, or exhaust pipe while the engine is running or soon after it has stopped, because these areas could be hot enough to cause burns.
- If the engine stalls or loses headway and cannot make it to the top of a slope, do not turn the machine around. Always back slowly, straight down the slope.
- When a person or pet appears unexpectedly in or near the mowing area, stop mowing. Do not resume mowing until the area is cleared.

Use paper or cardboard, not your hands, to search for leaks. Hydraulic fluid escaping under pressure can have sufficient force to penetrate the skin and cause serious injury. Seek immediate medical attention if fluid is injected into skin.

- Before disconnecting or performing any work on the hydraulic system, all pressure in the system must be relieved by stopping the engine and lowering the cutting units and attachments to the ground.
- Check all fuel lines for tightness and wear on a regular basis. Tighten or repair them as needed.
- If the engine must be running to perform a maintenance adjustment, keep your hands, feet, clothing, and any parts of the body away from the cutting units, attachments, and any moving parts. Keep everyone away.
- To ensure safety and accuracy, have your Toro Distributor check the maximum engine speed with a tachometer.
- For major repairs, warranty work, updates to systems, or assistance, contact your Toro Distributor.
- To ensure optimum performance and continued safety certification of the machine, use only genuine Toro replacement parts and accessories. Replacement parts and accessories made by other manufacturers could be dangerous, and such use could void the product warranty.

Maintenance and Storage

- Make sure that all hydraulic line connectors are tight and all hydraulic hoses and lines are in good condition before applying pressure to the system.
- Keep your body and hands away from pin-hole leaks or nozzles that eject hydraulic fluid under high pressure.

Safety and Instructional Decals



Safety decals and instructions are easily visible to the operator and are located near any area of potential danger. Replace any decal that is damaged or missing.

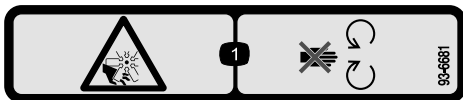

93-6681

decal93-6681

1. Cutting/dismemberment—hazard, fan-stay away from moving parts.



93-7276

decal93-7276

1. Explosion hazard—wear eye protection.
2. Caustic liquid/chemical burn hazard—to perform first aid, flush with water.
3. Fire hazard—no fire, open flames, or smoking.
4. Poison hazard—keep children a safe distance away from the battery.



93-6688

decal93-6688

1. Warning—read the *Operator's Manual* before performing maintenance.
2. Cutting hazard of hand or foot—shut off the engine and wait for all moving parts to stop.

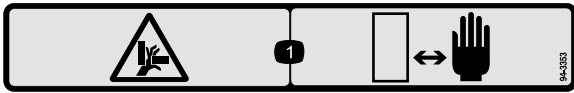

94-3353

decal94-3353

1. Crushing hazard of hand—keep your hands a safe distance away.

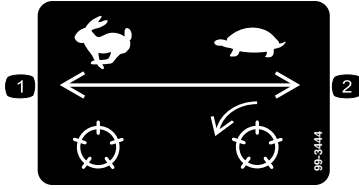

99-3444

decal99-3444

1. Transport speed—fast
2. Mowing speed—slow



110-0806

decal110-0806



117-2718

decal117-2718

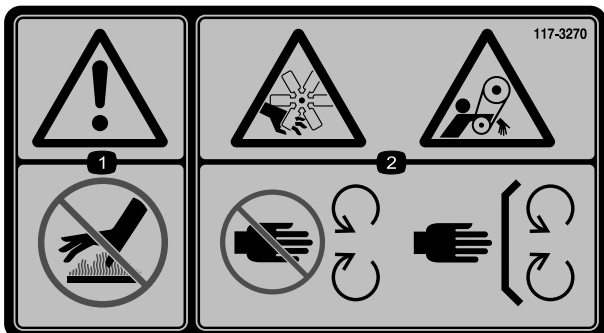

117-3270

decal117-3270

1. Warning—do not touch the hot surface.
2. Cutting/dismemberment hazard, hand; entanglement hazard, belt—stay away from moving parts, keep all guards and shields in place.

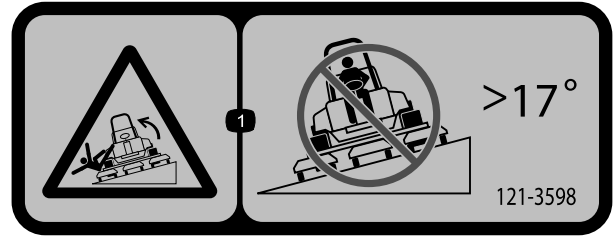

121-3598

decal121-3598

CE only

1. Tipping hazard—do not drive across slopes greater than 17 degrees.

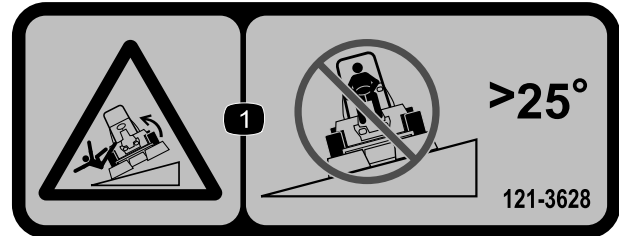

121-3628

decal121-3628

Non-CE only

1. Tipping hazard—do not drive across slopes greater than 25 degrees.

REELMASTER 3100-D

QUICK REFERENCE AID

CHECK/SERVICE (DAILY)

1. OIL LEVEL, ENGINE
2. ENGINE OIL DRAIN
(3/4" OR 19mm SOCKET)
3. OIL LEVEL, HYDRAULIC TANK
4. COOLANT LEVEL, RADIATOR
5. FUEL/WATER SEPARATOR
6. AIR CLEANER
7. RADIATOR SCREEN
8. PARKING BRAKE
9. TIRE PRESSURE (14-18 psi)
10. BATTERY
11. BELTS (FAN, ALTERNATOR, HYDRAULIC PUMP)
12. REEL SPEED & BACKLAP CONTROL
GREASING - SEE OPERATOR'S MANUAL

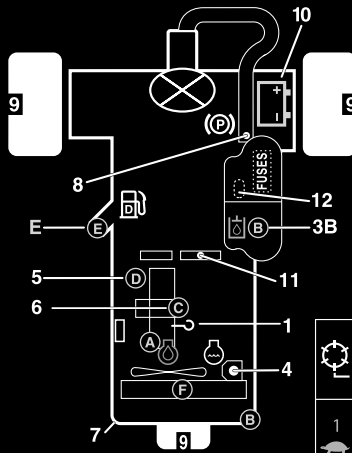

FUSES

MAX
15A

MAX
15A
OPTIONAL LIGHT

SYSTEM
10A
GAUGES
SCM PTO

2A
SCM

START
10A

FLUID SPECIFICATIONS/CHANGE INTERVALS

SEE OPERATOR'S MANUAL FOR INITIAL CHANGES.	FLUID TYPE	CAPACITY	CHANGE INTERVAL		FILTER PART NO.
			FLUID	FILTER	
A. ENGINE OIL	SAE 15W-40 CH-4	4.0 QTS.*	150 HRS.	150 HRS.	108-3841
B. HYD. CIRCUIT OIL	ISO VG 46/68	6 GAL.*	400 HRS.	200 HRS.	54-0110
C. AIR CLEANER				200 HRS.	108-3811
D. WATER SEPARATOR				400 HRS.	110-9049
E. FUEL TANK	NO. 2-DIESEL	7.5 GALS.	DRAIN AND FLUSH, 2 YRS.		
F. COOLANT	50/50 ETHYLENE GLYCOL/WATER	6 QTS.	DRAIN AND FLUSH, 2 YRS.		

*INCLUDING FILTER

		5 mph 8 kph	6 mph 10 kph	5 mph 8 kph	6 mph 10 kph	5 mph 8 kph	6 mph 10 kph
1	2 1/2" (64mm)	3	3	3	3		
	2 1/2" (60mm)	3	4	3	3		
	2 1/2" (57mm)	3	4	3	3		
	2 1/2" (54mm)	3	4	3	3		
	2" (51mm)	3	4	3	3		
	1 1/2" (48mm)	4	5	3	3		
	1 1/2" (44mm)	4	5	3	3		
	1 1/2" (41mm)	5	6	3	3		
	1 1/2" (38mm)	5	7	3	4		
	1 1/2" (35mm)	5	8	3	4		
	1 1/2" (32mm)	6	9	4	4		
	1 1/2" (29mm)	8	9	4	5		
	1" (25mm)	9	9	5	6		
	3/4" (22mm)	9	9	5	7		
9	3/4" (19mm)	9	9	7	9	6	7
	3/4" (16mm)	9	9	9	9	7	7
	3/4" (13mm)	9	9	9	9	8	8
	3/4" (10mm)	9	9	9	9	9	9

121-3607

121-3607

dca1121-3607

1. Read the *Operator's Manual* for more information on fuses, height of cut, and maintenance.

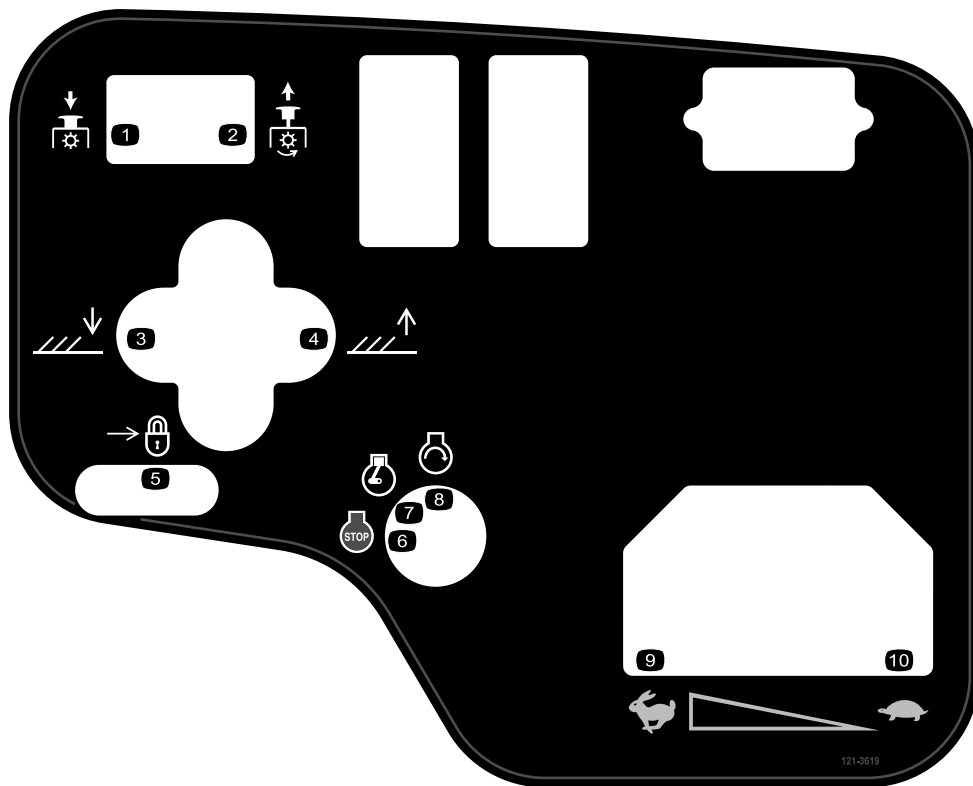

121-3619

Model 03170 only

decal121-3619

1. Push down to disengage the cutting units
2. Pull up to engage the cutting units.
3. Lower the cutting units.
4. Raise the cutting units.
5. Lock
6. Engine—stop
7. Engine—run
8. Engine—start
9. Fast
10. Slow

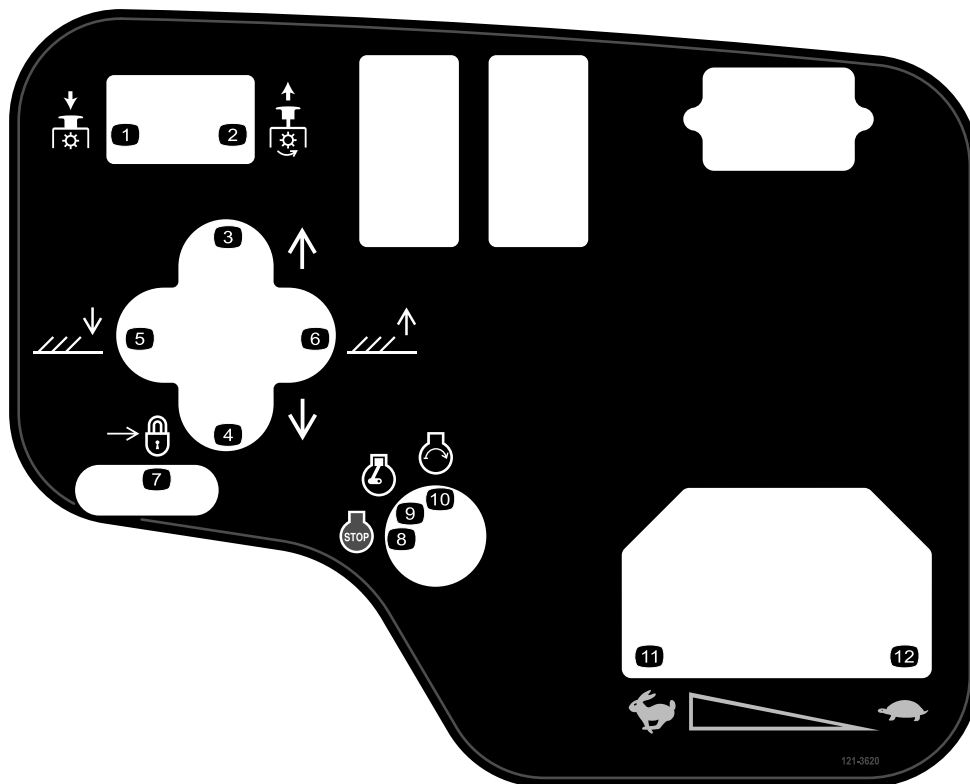

121-3620

Model 03171 only

decal121-3620

- | | |
|---|------------------|
| 1. Push down to disengage the cutting units | 7. Lock |
| 2. Pull up to engage the cutting units. | 8. Engine—stop |
| 3. Move the cutting units right. | 9. Engine—run |
| 4. Move the cutting units left. | 10. Engine—start |
| 5. Lower the cutting units. | 11. Fast |
| 6. Raise the cutting units. | 12. Slow |

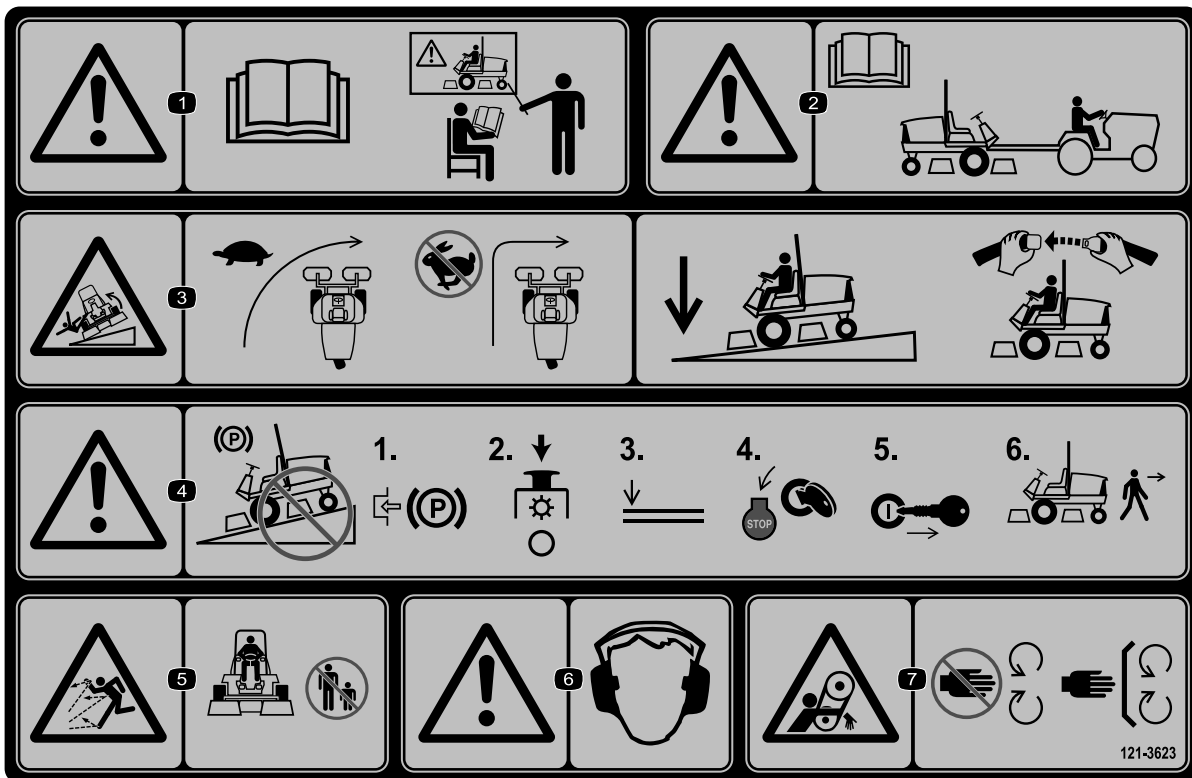

decal121-3623

121-3623

1. Warning—read the *Operator's Manual*; do not operate the machine unless you have received training.
2. Warning—read the *Operator's Manual* before towing the machine.
3. Tipping hazard—slow the machine before turning; when driving on slopes, keep the cutting units lowered and your seatbelt fastened.
4. Warning—do not park on slopes; engage the parking brake, stop the cutting units, lower the attachments, shut off the engine, and remove the key from the ignition before leaving the machine.
5. Thrown object hazard—keep bystanders away from the machine.
6. Warning—wear hearing protection.
7. Entanglement hazard—keep away from moving parts; keep all guards and shields in place.



Battery Symbols

Some or all of these symbols are on your battery

- | | |
|--|---|
| 1. Explosion hazard | 6. Keep bystanders a safe distance away from the battery. |
| 2. No fire, open flame, or smoking | 7. Wear eye protection; explosive gases can cause blindness and other injuries. |
| 3. Caustic liquid/chemical burn hazard | 8. Battery acid can cause blindness or severe burns. |
| 4. Wear eye protection. | 9. Flush eyes immediately with water and get medical help fast. |
| 5. Read the <i>Operator's Manual</i> . | 10. Contains lead; do not discard |
-

Setup

Loose Parts

Use the chart below to verify that all parts have been shipped.

Procedure	Description	Qty.	Use
1	Front wheel assemblies	2	Install the wheels.
	Rear wheel assembly	1	
2	Steering wheel	1	Install the steering wheel.
	Steering-wheel cap	1	
	Large washer	1	
	Jam nut	1	
	Screw	1	
3	Electrolyte	A/R	Activate, charge, and connect the battery.
4	Inclinometer	1	Check the angle indicator.
5	Warning decal (121-3598)	1	Install the CE decal (if required).
6	Lock bracket	1	Install the hood latch (CE).
	Rivet	2	
	Washer	1	
	Screw (1/4 x 2 inches)	1	
	Locknut (1/4 inch)	1	
7	Exhaust guard	1	Install the exhaust guard (CE).
	Self-tapping screw	4	
8	Roll-bar assembly	1	Install the roll bar.
	Flange-head bolts	4	
	Locknuts	4	
	Hose clamp	1	
9	Lift arms	2	Install the front lift arms. (Parts supplied in the Lift Arm Kit.)
	Pivot rod	2	
	Bolt (5/16 x 7/8 inch)	2	
10	No parts required	–	Install the carrier frames to the cutting units.
11	No parts required	–	Mount the cutting units.
12	No parts required	–	Mount the cutting unit drive motors.
13	No parts required	–	Adjust the lift arms.
14	Tipper roller kit (not included)	1	Install the optional tipper roller kit.

Media and Additional Parts

Description	Qty.	Use
Ignition key	2	Start the engine.
Operator's Manual Engine operator's manual	1 1	Read before operating the machine.
Operator training material	1	View before operating the machine.
Pre-delivery checklist	1	Check to ensure that the machine has been properly set up.
Certificate of compliance	1	Ensure CE compliance.

Note: Determine the left and right sides of the machine from the normal operating position.

1

Installing the Wheels

Parts needed for this procedure:

2	Front wheel assemblies
1	Rear wheel assembly

Procedure

1. Mount a wheel assembly onto each wheel hub (valve stem outward).

Important: The rear tire has a narrower rim than the front tires.

2. Install lug nuts and torque to 61 to 88 N·m (45 to 65 ft-lb).

2

Installing the Steering Wheel

Parts needed for this procedure:

1	Steering wheel
1	Steering-wheel cap
1	Large washer
1	Jam nut
1	Screw

Procedure

1. Slide the steering wheel onto the steering shaft (Figure 3).

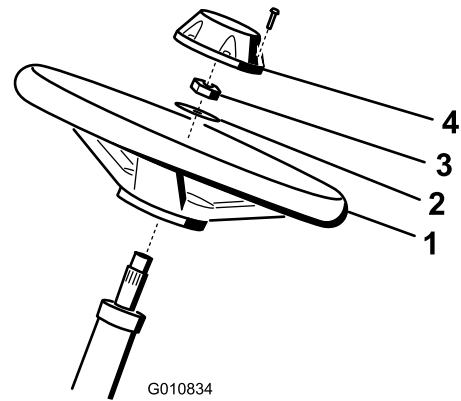

Figure 3

1. Steering wheel
 2. Washer
 3. Jam nut
 4. Cap
2. Slide the washer onto the steering shaft (Figure 3).
 3. Secure the steering wheel to the shaft with a jam nut and tighten it to 27 to 35 N·m (20 to 26 ft-lb) (Figure 3).
 4. Install the cap to the steering wheel and secure it with a screw (Figure 3).

3

Activating, Charging, and Connecting the Battery

Parts needed for this procedure:

A/R	Electrolyte
-----	-------------

Procedure

WARNING

CALIFORNIA Proposition 65 Warning

Battery posts, terminals, and related accessories contain lead and lead compounds, chemicals known to the State of California to cause cancer and reproductive harm.
Wash hands after handling.

Note: If the battery is not filled with electrolyte or activated, bulk electrolyte with 1.260 specific gravity must be purchased from a local battery supply outlet and added to the battery.

⚠ DANGER

Battery electrolyte contains sulfuric acid which is a deadly poison and causes severe burns.

- Do not drink electrolyte and avoid contact with skin, eyes, or clothing. Wear safety glasses to shield your eyes and rubber gloves to protect your hands.
 - Fill the battery where clean water is always available for flushing the skin.
1. Purchase bulk electrolyte with 1.260 specific gravity from a local battery supply outlet.
 2. Open the hood.
 3. Remove the battery cover (Figure 4).

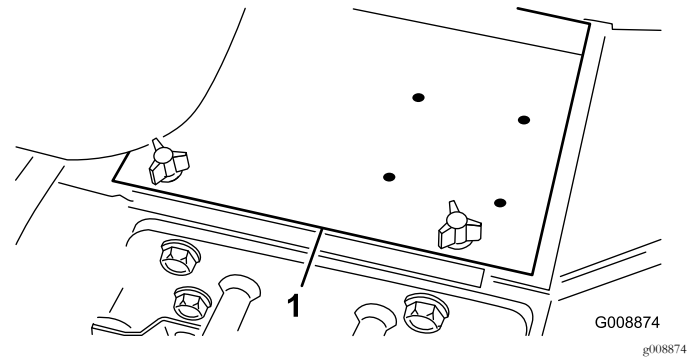

Figure 4

1. Battery cover
4. Remove the filler caps from the battery and slowly fill each cell until electrolyte is just above the plates.
5. Install the filler caps and connect a 3 to 4 A battery charger to the battery posts. Charge the battery at a rate of 3 to 4 A for 4 to 8 hours.
6. When the battery is charged, disconnect the charger from the electrical outlet and battery posts.
7. Remove the filler caps. Slowly add electrolyte to each cell until the level is up to the fill ring. Install the filler caps.
8. Install the positive cable (red) to the positive (+) terminal and the negative cable (black) to the negative (-) terminal of the battery and secure them with bolts and nuts (Figure 5). Make sure that the positive (+) terminal is all of the way onto the post and the cable is positioned snug to the battery. The cable must not contact the battery cover.

⚠ WARNING

Charging the battery produces gasses that can explode.

- Keep sparks and flames away from battery.
- Never smoke near the battery.

Important: Do not overfill the battery. Electrolyte will overflow onto other parts of the machine and severe corrosion and deterioration will result.

⚠ WARNING

Incorrect battery cable routing could damage the tractor and cables causing sparks. Sparks can cause the battery gasses to explode, resulting in personal injury.

- Always disconnect the negative (black) battery cable before disconnecting the positive (red) cable.
- Always connect the positive (red) battery cable before connecting the negative (black) cable.

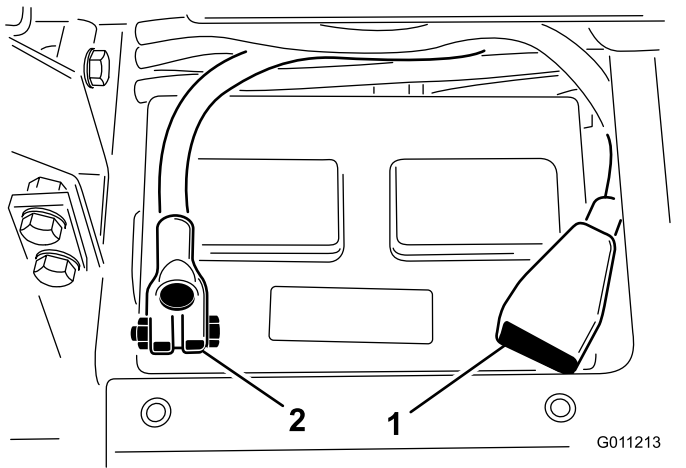

Figure 5

1. Positive (+) battery cable
2. Negative (-) battery cable

Important: If the battery is ever removed, make sure that the battery clamp bolts are installed with the bolt heads positioned on the bottom side and the nuts on the top side. If the clamp bolts are reversed, they may interfere with the hydraulic tubes when shifting the cutting units.

9. Coat both battery connections with Grafo 112X (skin over) grease, Toro Part No. 505-47, petroleum jelly, or light grease to prevent corrosion.
10. Slide the rubber boot over the positive terminal to prevent a possible short from occurring.
11. Install the battery cover.

4

Checking the Angle Indicator

Parts needed for this procedure:

1	Inclinometer
---	--------------

Procedure

⚠ DANGER

To reduce risk of injury or death due to rollover, do not operate the machine on side hills steeper than 25°.

1. Park the machine on a flat, level surface.
2. Verify that the machine is level by placing a hand held inclinometer (supplied with the machine) on the frame cross rail, by the fuel tank (Figure 6). The inclinometer should read zero degrees when viewed from the operator's position.

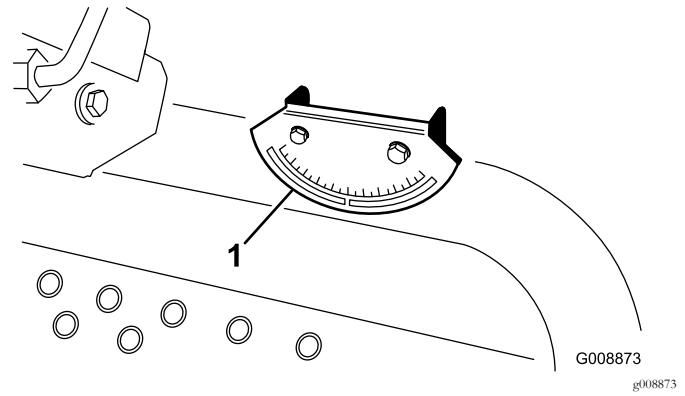

Figure 6

1. Angle indicator

3. If the inclinometer does not read zero degrees, move the machine to a location where a zero degree reading is obtained. The angle indicator, mounted on the machine, should now read zero degrees as well.
4. If the angle indicator does not read zero degrees, loosen the 2 screws and nuts securing the angle indicator to the mounting bracket, adjust the indicator to obtain a zero degree reading, and tighten the bolts.

5

Installing the CE Decal

Parts needed for this procedure:

1	Warning decal (121-3598)
---	--------------------------

Procedure

If this machine will be used for CE, affix the CE decal over the corresponding non-CE decal.

6

Installing the Hood Latch (CE Only)

Parts needed for this procedure:

1	Lock bracket
2	Rivet
1	Washer
1	Screw (1/4 x 2 inches)
1	Locknut (1/4 inch)

Procedure

1. Unhook the hood latch from the hood-latch bracket.
2. Remove the rivets (2) securing the hood-latch bracket to the hood (Figure 7). Remove the hood-latch bracket from the hood.

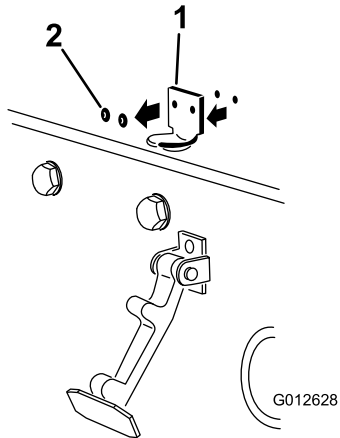

Figure 7

1. Hood-latch bracket
2. Rivets

3. While aligning the mounting holes, position the CE lock bracket and the hood-latch bracket onto the hood. The lock bracket must be against the hood (Figure 8). Do not remove the bolt and nut assembly from the lock bracket arm.

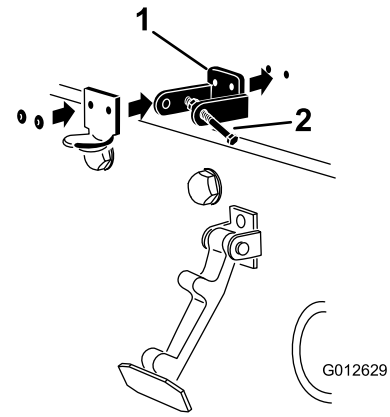

Figure 8

1. CE lock bracket
2. Bolt and nut assembly

4. Align the washers with the holes on the inside of the hood.
5. Rivet the brackets and the washers to the hood (Figure 8).
6. Hook the latch onto the hood-latch bracket (Figure 9).

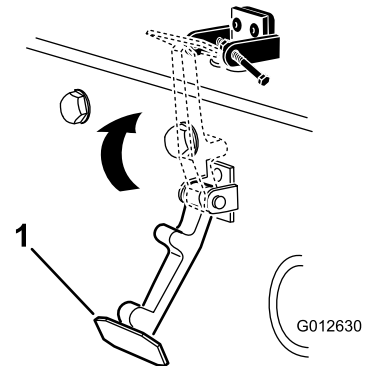

Figure 9

1. Hood latch

7. Screw the bolt into the other arm of hood-lock bracket to lock the latch in position (Figure 10).

Note: Tighten the bolt securely but do not tighten the nut.

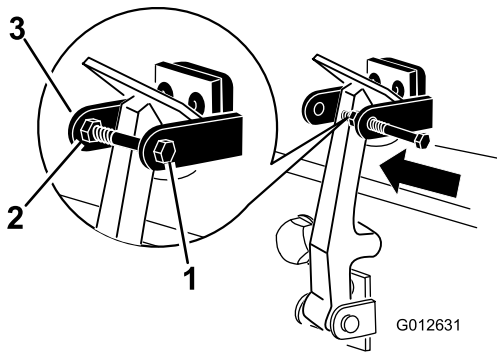

Figure 10

g012631

- 1. Bolt
- 2. Nut
- 3. Arm of hood-lock bracket

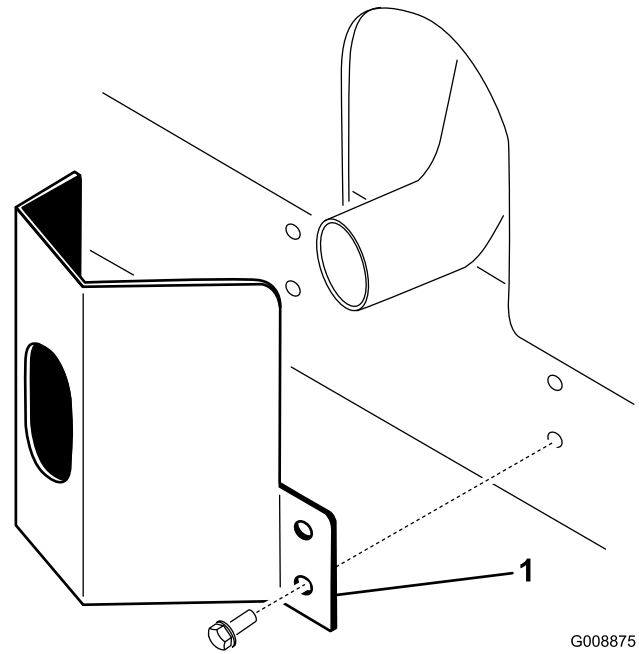

Figure 11

G008875
g008875

- 1. Exhaust guard
- 2. Secure the exhaust guard to the frame with 4 self-tapping screws (Figure 11).

7

Installing the Exhaust Guard (CE Only)

Parts needed for this procedure:

1	Exhaust guard
4	Self-tapping screw

Procedure

1. Position the exhaust guard around the muffler while aligning the mounting holes with the holes in the frame (Figure 11).

8

Installing the Roll Bar

Parts needed for this procedure:

1	Roll-bar assembly
4	Flange-head bolts
4	Locknuts
1	Hose clamp

Procedure

Important: Never weld or modify a rollover protection system (ROPS). Replace a damaged ROPS; do not repair or revise it.

1. Lower the roll bar onto the traction unit mounting brackets, aligning the mounting holes. Ensure that the vent tube on the roll bar is on the left side of the machine (Figure 12).

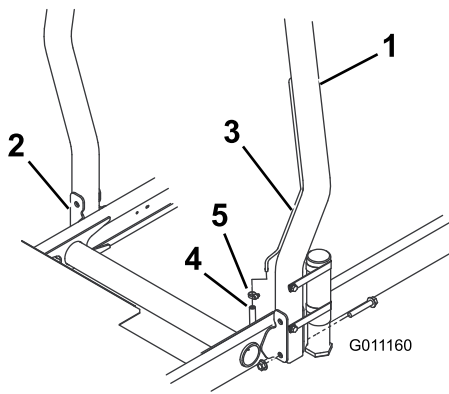

Figure 12

- 1. ROPS
- 2. Mounting bracket
- 3. Vent tube
- 4. Fuel line vent tube hose
- 5. Hose clamp

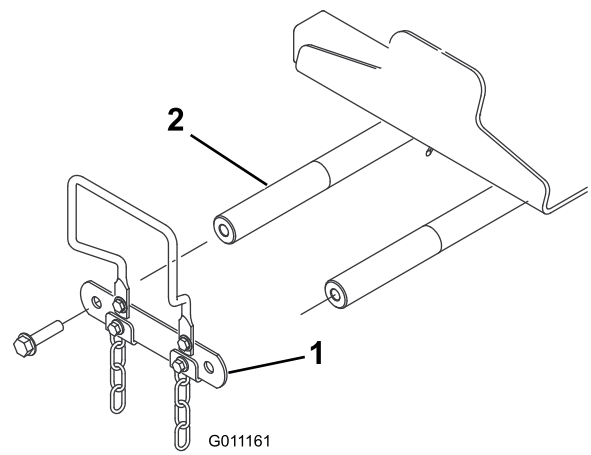

Figure 13

- 1. Lift arm pivot shaft link
- 2. Lift arm pivot shaft

2. Secure each side of the roll bar to the mounting brackets with 2 flange head bolts and locknuts (Figure 12). Torque the fasteners to 81 N·m (60 ft-lb).
3. Secure the fuel line vent hose to the vent tube on the roll bar with the hose clamp.

CAUTION

Starting the engine with the fuel line vent hose disconnected from the vent tube will cause fuel will flow from the hose, increasing the risk of fire or explosion. A fire or explosion from fuel can burn you and others and can cause property damage.

Connect the fuel line vent hose to the vent tube prior to starting the engine.

2. Insert a pivot rod into each lift arm and align the mounting holes (Figure 14).

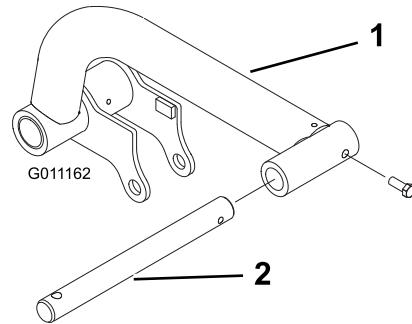

Figure 14

- 1. Lift arm
- 2. Pivot rod

3. Secure the pivot rods to the lift arms with 2 bolts (5/16 x 7/8 inch).
4. Insert the lift arms onto the lift arm pivot shafts (Figure 15), and secure each with a lift arm pivot shaft link and bolts previously removed.

Note: Torque the bolts to 95 N·m (70 ft-lb).

9

Installing the Front Lift Arms

Parts needed for this procedure:

2	Lift arms
2	Pivot rod
2	Bolt (5/16 x 7/8 inch)

Procedure

1. Remove the 2 bolts that secure the lift arm pivot shaft link to the lift arm pivot shafts, and remove and retain the pivot shaft link and bolts (Figure 13).

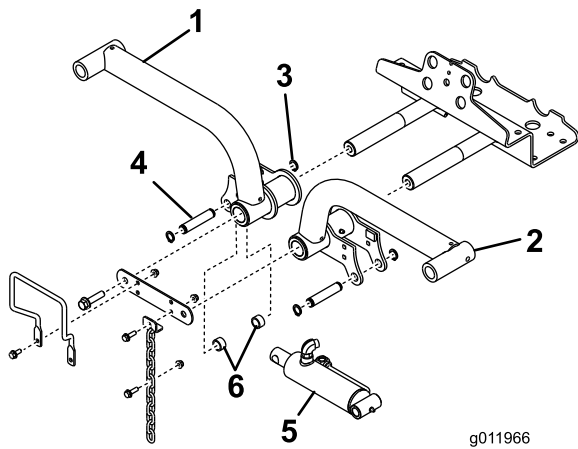

Figure 15

- | | |
|--------------------|------------------|
| 1. Lift arm, right | 4. Lift cylinder |
| 2. Retaining ring | 5. Spacers (2) |
| 3. Lift arm, left | 6. Mounting pin |

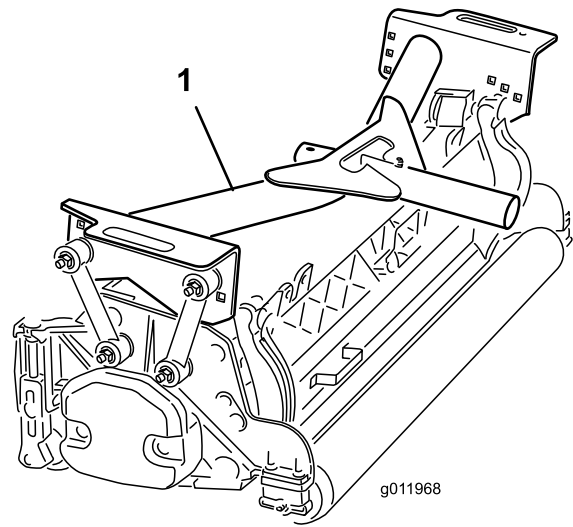

Figure 16

1. Front carrier frame

5. Remove the rear retaining rings securing the mounting pins to each end of the lift cylinder.
6. Secure the right end of the lift cylinder to the right lift arm with a pin and 2 spacers (Figure 15). Secure it with a retaining ring.
7. Secure the left end of the lift cylinder to the left lift arm with a pin. Secure it with a retaining ring.

3. Secure the mounting links to the **front** carrier frames as follows:
 - Secure the front mounting links to the middle carrier frame holes with a bolt (3/8 x 2-1/4 inch), 2 flat washers, and a locknut, as shown in Figure 17. Position a washer on each side of the link when mounting. Torque the fasteners to 42 N·m (31 ft-lb).
 - Secure the rear mounting links to the middle carrier frame holes with a bolt (3/8 x 2-1/4 inch), 2 flat washers, and a locknut, as shown in Figure 17. Position a washer on each side of the link when mounting. Torque the fasteners to 42 N·m (31 ft-lb).

10

Installing the Carrier Frames to the Cutting Units

No Parts Required

Procedure

1. Remove the cutting units from the cartons. Adjust them as described in the cutting unit operator's manual.
2. Position a front carrier frame (Figure 16) onto each front cutting unit.

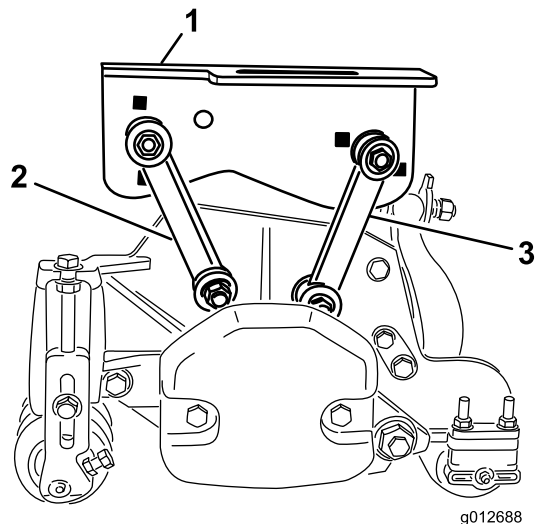

Figure 17

1. Front carrier frame
2. Front mounting link
3. Rear mounting link

- Position the rear carrier frame (Figure 18) onto the rear cutting unit.

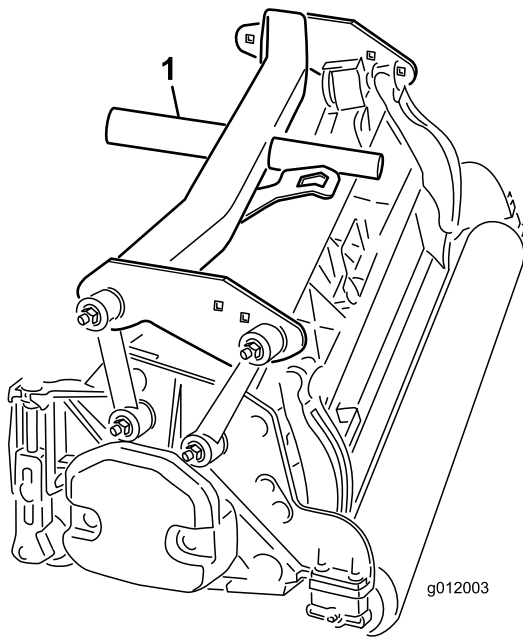

Figure 18

- Rear carrier frame

- Secure the mounting links to the **rear** carrier frame as follows:
 - Secure the front mounting links to the carrier frame holes with a bolt (3/8 x 2-1/4 inch), 2 flat washers, and a locknut, as shown in Figure 19. Position a washer on each side of the link when mounting. Torque the fasteners to 42 N·m (31 ft-lb).
 - Secure the rear mounting links to the rear carrier frame holes with a bolt (3/8 x 2-1/4 inch), 2 flat washers, and a locknut, as shown in Figure 19. Position a washer on each side of the link when mounting. Torque the fasteners to 42 N·m (31 ft-lb).

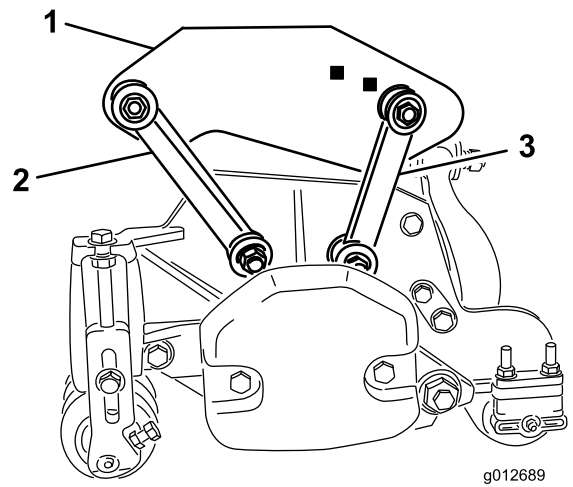

Figure 19

- Rear carrier frame
- Front mounting link
- Rear mounting link

11

Mounting the Cutting Units

No Parts Required

Procedure

- Slide a thrust washer onto each front lift arm pivot rod.
- Slide the cutting unit carrier frame onto the pivot rod and secure it with a lynch pin (Figure 20).

Note: On rear cutting unit, position the thrust washer between the rear of the carrier frame and the lynch pin.

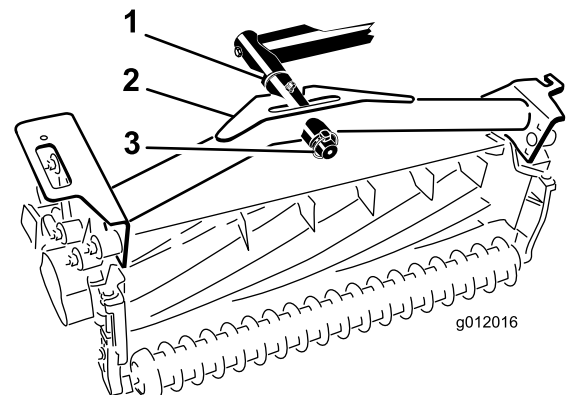

Figure 20

- Thrust washer
- Carrier frame
- Lynch pin

- Grease all the lift arm and carrier frame pivot points.

Important: Ensure that the hoses are free of twists or sharp bends and that the rear cutting unit hoses are routed as show in (Figure 21). Raise the cutting units and shift them to the left (Model 03171). The rear cutting unit hoses must not contact traction cable bracket. Reposition the fittings and/or hoses, if necessary.

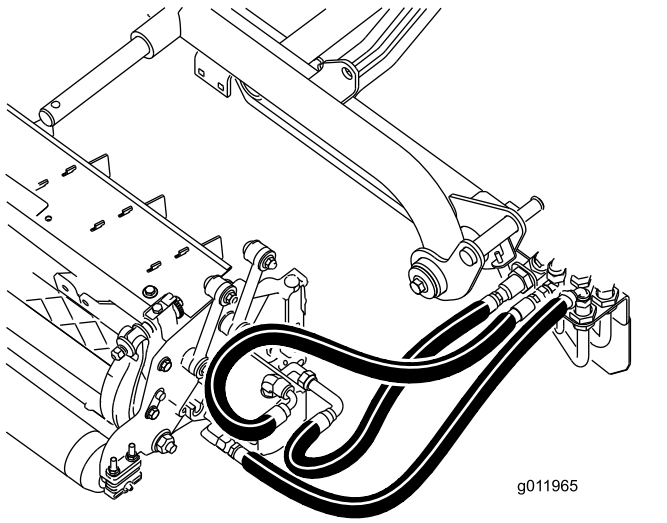

Figure 21

- Route a tipper chain up through the slot on the end of each carrier frame. Secure the tipper chain to the top of the carrier frame with a bolt, a washer, and a locknut (Figure 22).

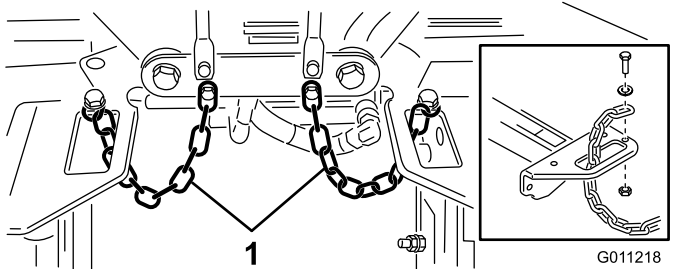

Figure 22

- Tipper chain

12

Mounting the Cutting Unit Drive Motors

No Parts Required

Procedure

- Position the cutting units in front of the lift arm pivot rods.
- Remove the weight and O-ring (Figure 23) from the inside end of the right cutting unit.

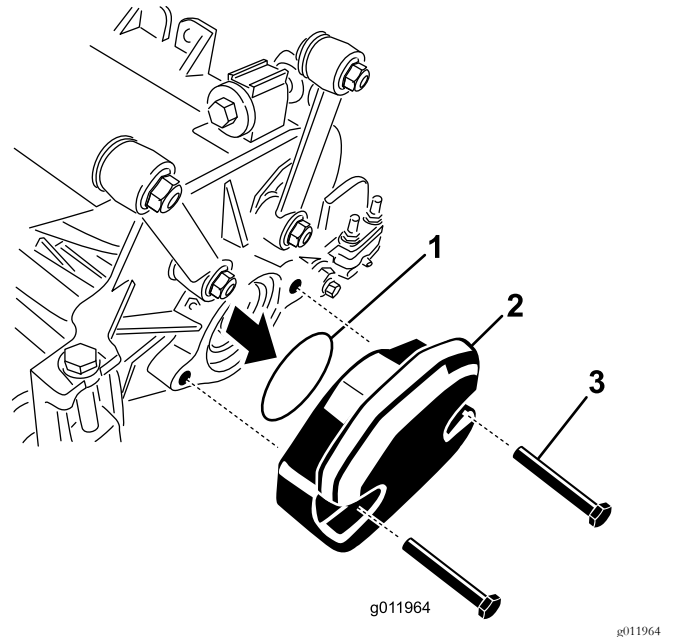

Figure 23

- O-ring
- Weight
- Mounting bolts

- Remove the plug from the bearing housing on the outside end of the right cutting unit and install the weights and gasket.
- Remove the shipping plug from the bearing housings on the remaining cutting units.
- Insert the O-ring (supplied with the cutting unit) on the flange of the drive motor (Figure 24).

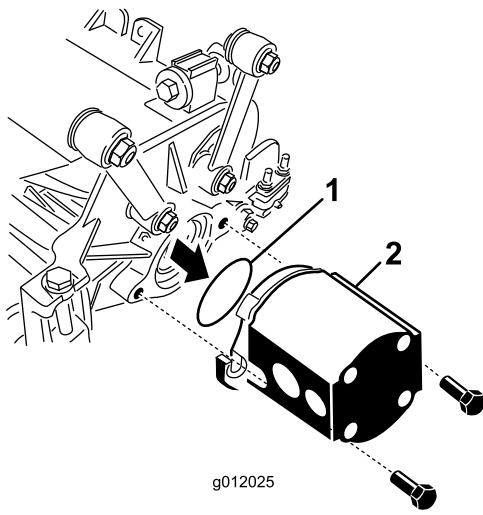

Figure 24

- 1. O-ring
- 2. Reel motor

6. Mount the motor to the drive end of the cutting unit, and secure it with 2 cap screws provided with cutting unit (Figure 24).

13

Adjusting the Lift Arms

No Parts Required

Procedure

1. Start the engine, raise the lift arms, and check to ensure that the clearance between each lift arm and the floor plate bracket is 5 to 8 mm (0.18 to 0.32 inches) (Figure 25).

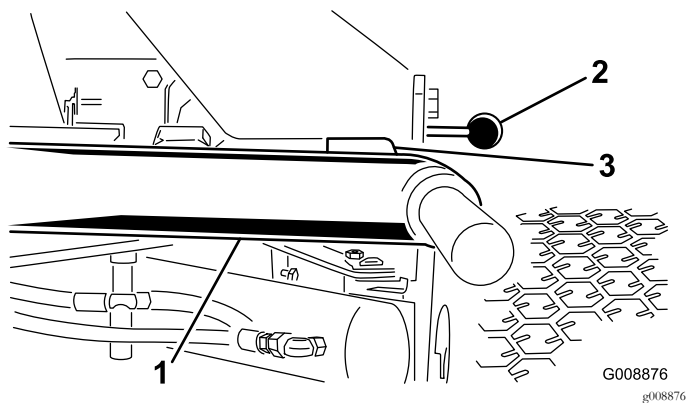

Figure 25

Cutting units removed for clarity

- 1. Lift arm
- 2. Floor plate bracket
- 3. Clearance

Note: If the clearance is not in this range, adjust the cylinder as follows:

- A. Back off the stop bolts and adjust the cylinder to attain the clearance (Figure 26).

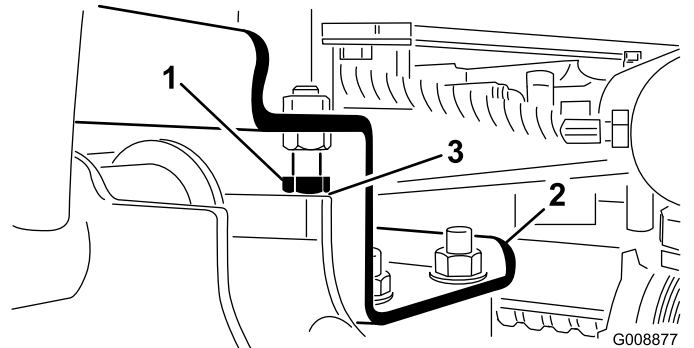

Figure 26

- 1. Stop bolt
- 2. Lift arm
- 3. Clearance

- B. Back off the jam nut on the cylinder (Figure 27).

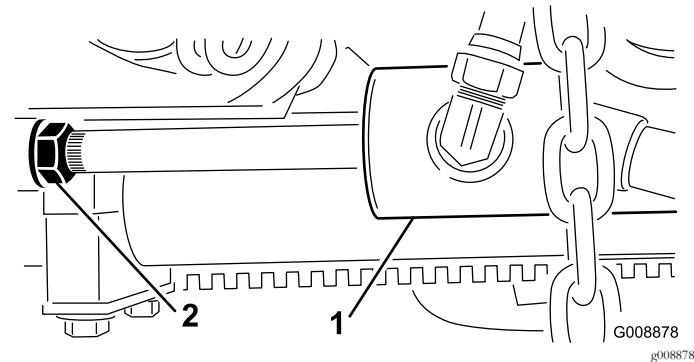

Figure 27

- 1. Front cylinder
- 2. Jam nut

- C. Remove the pin from the rod end and rotate the clevis.
- D. Install the pin and check the clearance.
- E. Repeat steps A through D if necessary.
- F. Tighten the clevis jam nut.

Note: If the rear lift arm clunks during transport, reduce the clearance.

2. Check to ensure that the clearance between each lift arm and stop bolt is 0.13 to 1.02 mm (0.005 to 0.040 inches) (Figure 26).

Note: If the clearance is not in this range, adjust the stop bolts to attain clearance.

3. Start the engine, raise the lift arms, and check to ensure that the clearance between the wear strap on the top of the rear cutting unit wear bar and the bumper strap is 0.51 to 2.54 mm (0.02 to 0.10 inches) as shown in Figure 28.

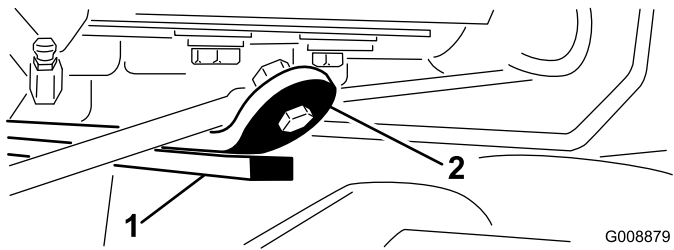

Figure 28

1. Wear bar 2. Bumper strap

If the clearance is not in this range, adjust the rear cylinder as follows:

- A. Lower the cutting units and back off the jam nut on the cylinder (Figure 29).

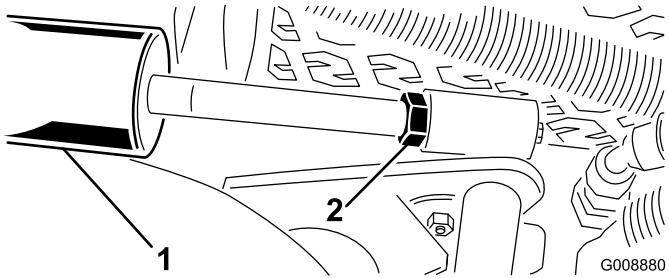

Figure 29

1. Rear cylinder 2. Adjusting nut

- B. Grasp the cylinder rod close to the nut with a pliers and rag and rotate the rod.
 C. Raise the cutting units and check the clearance.
 D. Repeat steps A through C if necessary.
 E. Tighten the clevis jam nut.

Important: Lack of clearance at the front stops or the rear wear bar could damage the lift arms.

14

Installing the Tipper Roller Kit (Optional)

Parts needed for this procedure:

1	Tipper roller kit (not included)
---	----------------------------------

Procedure

When cutting in higher heights of cut, it is recommended that the Tipper Roller Kit be installed.

1. Raise the cutting units all the way up.

2. Locate the frame bracket above the center cutting unit (Figure 30).
 3. While pressing down on the front roller of the center cutting unit, determine which holes on the tipper bracket align with the frame bracket holes to attain the same roller contact when the tipper bracket is installed (Figure 30).

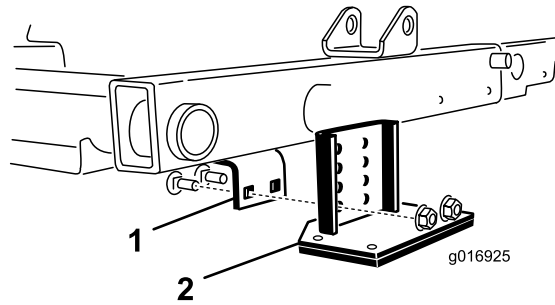

Figure 30

1. Frame bracket 2. Tipper bracket

4. Lower the cutting units and mount the tipper bracket to the frame with the 2 carriage bolts and 2 nuts supplied with the kit (Figure 30).

Product Overview

Controls

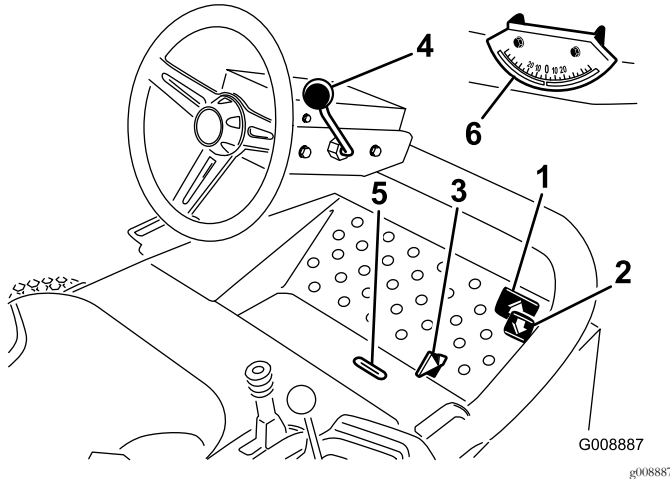

Figure 31

- | | |
|---------------------------|------------------------|
| 1. Forward traction pedal | 4. Tilt steering lever |
| 2. Reverse traction pedal | 5. Indicator slot |
| 3. Mow/transport slide | 6. Angle indicator |

Traction Pedals

Press the traction forward pedal (Figure 31) to move forward. Press the traction reverse pedal (Figure 31) to move backward or to assist in stopping when moving forward. Also, allow the pedal to move or move it to the NEUTRAL position to stop the machine.

Mow/Transport Slide

Using your heel, move the mow/transport slide (Figure 31) to the left to transport and to the right to mow. **The cutting units operate only in the mow position.**

Important: The mow speed is set at the factory to 9.7 km/h (6 mph). It can be increased or decreased by adjusting the speed stop screw (Figure 32).

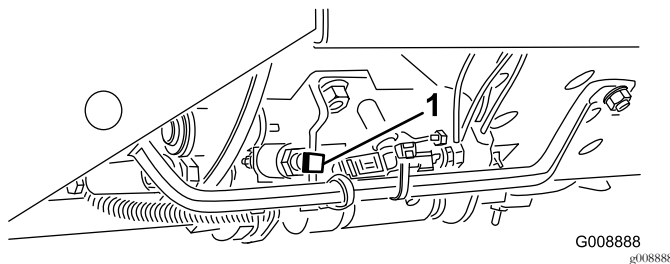

Figure 32

1. Speed stop screw

Tilt Steering Lever

Pull the tilt steering lever (Figure 31) back to adjust the steering wheel to the desired position, then push the lever forward to tighten.

Indicator Slot

The slot in the operator platform (Figure 31) indicates when the cutting units are in the center position.

Angle Indicator

The angle indicator (Figure 31) indicates the side hill angle of the machine in degrees.

Ignition Switch

The ignition switch (Figure 33), which is used to start, stop, and preheat the engine, has 3 positions: OFF, ON/PREHEAT, and START. Rotate the key to the ON/PREHEAT position until the glow plug indicator light goes out (approximately 7 seconds); then rotate the key to the START position to engage the starter motor. Release the key when the engine starts. The key automatically moves to the ON/RUN position. To shut off the engine, rotate the key to the OFF position and remove the key from the switch to prevent accidental starting.

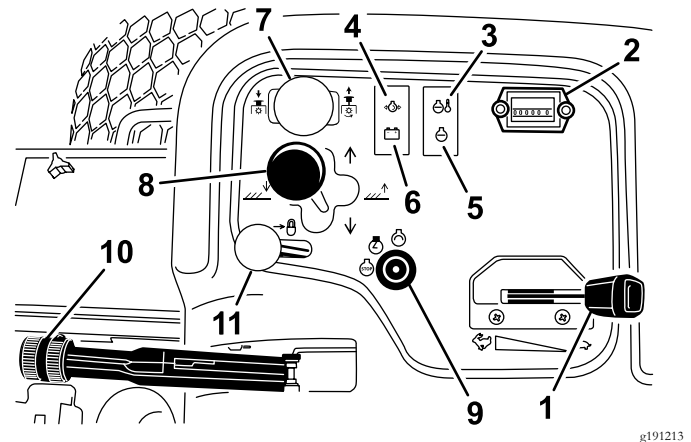

Figure 33

- | | |
|------------------------------|------------------------------|
| 1. Throttle | 7. Cutting-unit drive switch |
| 2. Hour meter | 8. Cutting-unit shift lever |
| 3. Temperature light | 9. Ignition switch |
| 4. Oil-pressure light | 10. Parking brake |
| 5. Glow-plug indicator light | 11. Lift lever lock |
| 6. Alternator light | |

Throttle

Move the throttle (Figure 33) forward to increase the engine speed and rearward to decrease the engine speed.

Cutting Unit Drive Switch

The cutting unit drive switch (Figure 33) has 2 positions: ENGAGE and DISENGAGE. The rocker switch operates a solenoid valve on the valve bank to drive the cutting units.

Hour Meter

The hour meter (Figure 33) indicates the total hours of machine operation. The hour meter starts to function whenever the key switch is on.

Cutting Unit Shift Lever

To lower the cutting units to the ground, move the cutting unit shift lever (Figure 33) forward. The cutting units do not drop unless the engine is running, and they do not operate in the raised position. To raise the cutting units, pull the shift lever rearward to the RAISE position.

Move the lever to the right or left to move the cutting units in the same direction. This should only be done when the cutting units are raised or if they are on the ground and the machine is moving (Model 03171 only).

Note: The lever does not have to be held in the forward position while the cutting units are lowered.

⚠ DANGER

Shifting the cutting units downhill decreases machine stability. This could cause a rollover, which may result in personal injury or death.

Shift the cutting units uphill while on a side hill.

Engine Coolant Temperature Warning Light

The temperature warning light (Figure 33) glows if the engine coolant temperature is high. If you do not stop the traction unit and the coolant temperature rises another 10°F, the engine shuts off.

Oil Pressure Warning Light

The oil pressure warning light (Figure 33) glows if the engine oil pressure drops below a safe level.

Alternator Light

The alternator light (Figure 33) should be off when the engine is running. If it is on, check and repair the charging system as needed.

Glow Plug Indicator

The glow plug indicator light (Figure 33) glows when the glow plugs are operating.

Parking Brake

Whenever the engine is shut off, engage the parking brake (Figure 33) to prevent accidental movement of the machine. To engage the parking brake, pull up on the lever. The engine stops if you press the traction pedal with the parking brake engaged.

Lift Lever Lock

Move the lift lever lock (Figure 33) rearward to prevent the cutting units from dropping.

Reel Speed Control

The reel speed control is located under the console cover (Figure 34). To obtain the desired clip rate (reel speed), rotate the reel speed control knob to the appropriate height-of-cut setting and mower speed. Refer to [Selecting the Clip Rate \(Reel Speed\)](#) (page 39).

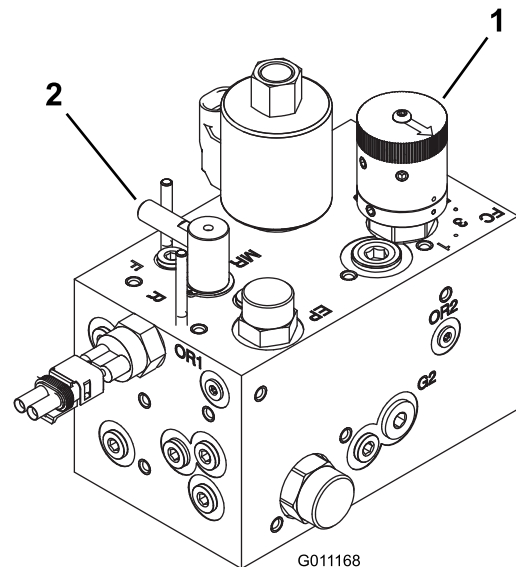

Figure 34

1. Reel speed control
2. Backlap control

Backlap Control

The backlap control is located under the console cover (Figure 34). Rotate the knob to R for backlapping and to F for mowing. Do not change the knob position while the reels are rotating.

Fuel Gauge

The fuel gauge (Figure 35) registers the amount of fuel in the tank.

parts. When it comes to reliability, Toro delivers replacement parts designed to the exact engineering specification of our equipment. For peace of mind, insist on Toro genuine parts.

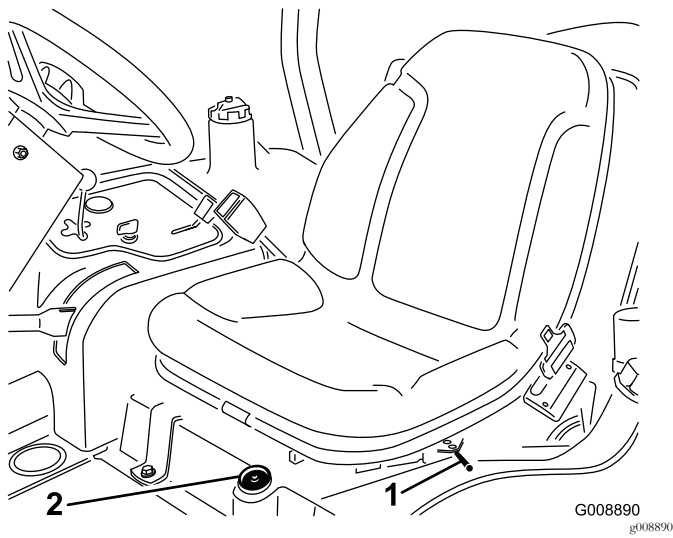

Figure 35

1. Fore and aft lever
2. Fuel gauge

Fore and Aft Seat Adjustments

Move the lever (Figure 35) on the side of the seat outward, slide the seat to the desired position, and release the lever to lock the seat into position.

Specifications

Note: Specifications and design are subject to change without notice.

Transport width	203 cm (80 inches) in 183 cm (72 inches) width of cut 234 cm (92 inches) in 216 cm (85 inches) width of cut
Width of cut	183 cm (72 inches) or 216 cm (85 inches)
Length	248 cm (93 inch)
Height	193 cm (76 inches) with ROPS
Net weight*	844 kg (1,860 lb)
Fuel tank capacity	28 L (7.5 US gallons).
Ground speed	Mow: 0 to 10 km/h (0 to 6 mph); Transport: 0 to 14 km/h (0 to 9 mph). Reverse: 0 to 6 km/h (0 to 4 mph)
* With cutting units and fluids	

Attachments/Accessories

A selection of Toro approved attachments and accessories is available for use with the machine to enhance and expand its capabilities. Contact your Authorized Service Dealer or Distributor or go to www.Toro.com for a list of all approved attachments and accessories.

To best protect your investment and maintain optimal performance of your Toro equipment, count on Toro genuine

Operation

Note: Determine the left and right sides of the machine from the normal operating position.

Think Safety First

Carefully read all safety instructions and symbols in the safety section. Knowing this information could help you or bystanders avoid injury.

▲ DANGER

Operating on wet grass or steep slopes can cause sliding and loss of control.

Wheels dropping over edges can cause rollovers, which may result in serious injury, death, or drowning.

Read and follow the rollover protection instructions and warnings.

To avoid loss of control and possibility of rollover:

- Do not operate near drop-offs or near water.
- Do not operate on slopes greater than specified for your machine model.
- Reduce speed and use extreme caution on slopes.
- Avoid sudden turns or rapid speed changes.

▲ CAUTION

This machine produces sound levels that can cause hearing loss through extended periods of exposure.

Wear hearing protection when operating this machine.

Wear protective equipment for your eyes, ears, hands, feet, and head.

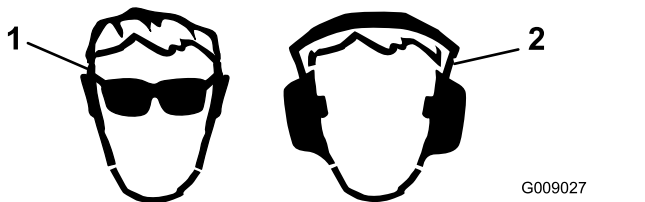

Figure 36

1. Wear eye protection.
2. Wear hearing protection.

Checking the Engine-Oil Level

Service Interval: Before each use or daily

The engine is shipped with oil in the crankcase; however, the oil level must be checked before and after the engine is first started.

The crankcase capacity is approximately 3.8 L (4.0 US qt) with the filter.

Use high-quality engine oil that meets the following specifications:

- API Classification Level Required: CH-4, CI-4 or higher.
- Preferred oil: SAE 15W-40 (above -17°C (0°F))
- Alternate oil: SAE 10W-30 or 5W-30 (all temperatures)

Note: Toro Premium Engine oil is available from a distributor in either 15W-40 or 10W-30 viscosity. See the parts catalog for part numbers.

Note: The best time to check the engine oil is when the engine is cool before it has been started for the day. If it has already been run, allow the oil to drain back down to the sump for at least 10 minutes before checking. If the oil level is at or below the Add mark on the dipstick, add oil to bring the oil level to the Full mark. **Do not overfill.** If the oil level is between the Full and Add marks, you do not need to add oil.

1. Park the machine on a level surface, lower the cutting units, shut off the engine, engage the parking brake, and remove the key from the ignition switch.
2. Remove the dipstick (Figure 37) and wipe it with a clean rag.

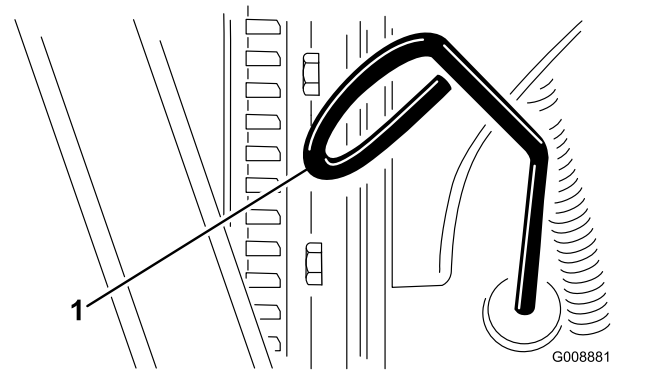

Figure 37

1. Dipstick
3. Push the dipstick down into the dipstick tube and ensure that it is seated fully, then pull the dipstick out and check the oil level.
4. If the oil level is low, remove the oil-fill cap (Figure 38) and gradually add small quantities of oil, checking the level frequently, until the level reaches the Full mark on the dipstick.

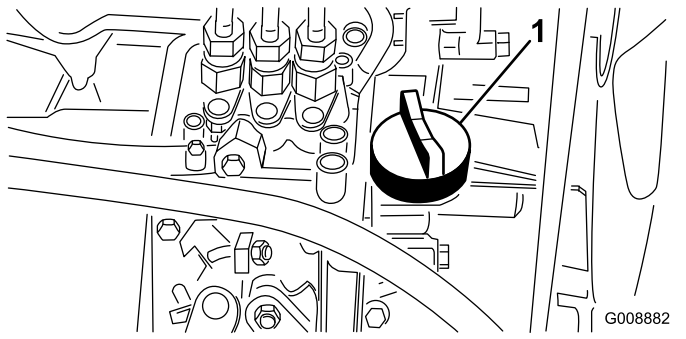

Figure 38

1. Oil-fill cap

5. Install the oil-fill cap and close the hood.

Important: Keep the engine-oil level between the upper and lower limits on the oil gauge. Engine failure may occur as a result of overfilling or underfilling the engine oil.

Filling the Fuel Tank

⚠ DANGER

Under certain conditions, diesel fuel and fuel vapors are highly flammable and explosive. A fire or explosion from fuel can burn you and others and can cause property damage.

- Use a funnel and fill the fuel tank outdoors, in an open area, when the engine is off and is cold. Wipe up any fuel that spills.
- Do not fill the fuel tank completely full. Add fuel to the fuel tank until the level is 6 to 13 mm (1/4 to 1/2 inch) below the bottom of the filler neck. This empty space in the tank allows the fuel to expand.
- Never smoke when handling fuel, and stay away from an open flame or where fuel fumes may be ignited by a spark.
- Store fuel in a clean, safety-approved container and keep the cap in place.

Use only clean, fresh diesel fuel or biodiesel fuels with low (<500 ppm) or ultra low (<15 ppm) sulfur content. The minimum cetane rating should be 40. Purchase fuel in quantities that can be used within 180 days to ensure fuel freshness.

The fuel tank capacity is approximately 28 L (7.5 US gallons).

Use summer-grade diesel fuel (No. 2-D) at temperatures above -7°C (20°F) and winter-grade (No. 1-D or No. 1-D/2-D blend) below that temperature. Using winter-grade fuel at lower temperatures provides a lower flash point and cold flow characteristics, which eases starting and reduces plugging of the fuel filter.

Using summer-grade fuel above -7°C (20°F) contributes toward longer fuel pump life and increased power compared to winter grade fuel.

Biodiesel Ready

This machine can also use a biodiesel blended fuel of up to B20 (20% biodiesel, 80% petrodiesel). The petrodiesel portion should be low or ultra low sulfur. Observe the following precautions:

- The biodiesel portion of the fuel must meet specification ASTM D6751 or EN14214.
- The blended fuel composition should meet ASTM D975 or EN590.
- Painted surfaces may be damaged by biodiesel blends.
- Use B5 (biodiesel content of 5%) or lesser blends in cold weather.
- Monitor seals, hoses, gaskets in contact with fuel as they may be degraded over time.
- Fuel filter plugging may be expected for a time after converting to biodiesel blends.
- Contact a distributor for more information on biodiesel blended fuel.

1. Clean the area around the fuel-tank cap ([Figure 39](#)).

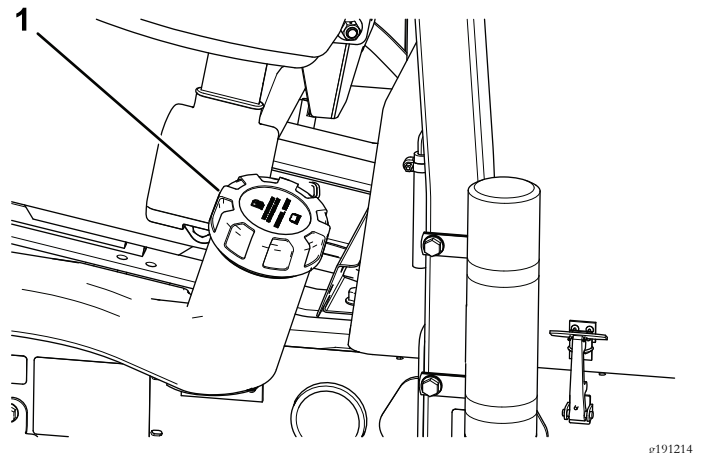

Figure 39

1. Fuel-tank cap

2. Remove the fuel-tank cap.
3. Fill the tank to the bottom of the filler neck.

Note: Do not overfill the fuel tank.

4. Install the cap.
5. Wipe up any fuel that may have spilled.

Checking the Cooling System

Service Interval: Before each use or daily

Clean debris off the radiator daily ([Figure 40](#)). Clean the radiator hourly if conditions are extremely dusty and dirty; refer to [Cleaning the Engine Cooling System](#) (page 53).

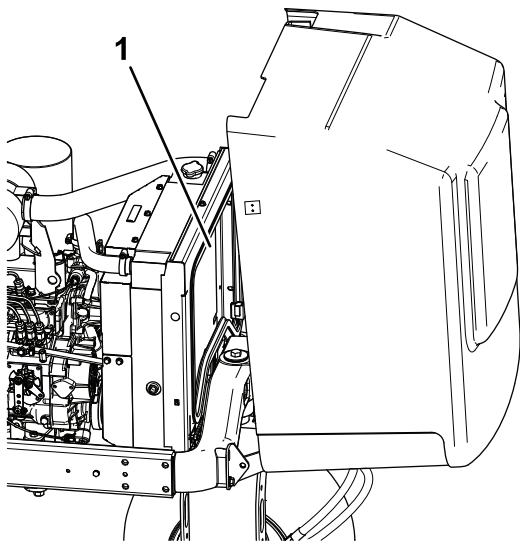

Figure 40

g190823

1. Radiator

The cooling system is filled with a 50/50 solution of water and permanent ethylene glycol antifreeze. Check the coolant level at the beginning of each day before starting the engine.

The capacity of the cooling system is approximately 5.7 L (6 US qt).

CAUTION

If the engine has been running, the pressurized, hot coolant can escape and cause burns.

- Do not open the radiator cap when the engine is running.
- Use a rag when opening the radiator cap, and open the cap slowly to allow steam to escape.

1. Check the coolant level in the expansion tank (Figure 41).

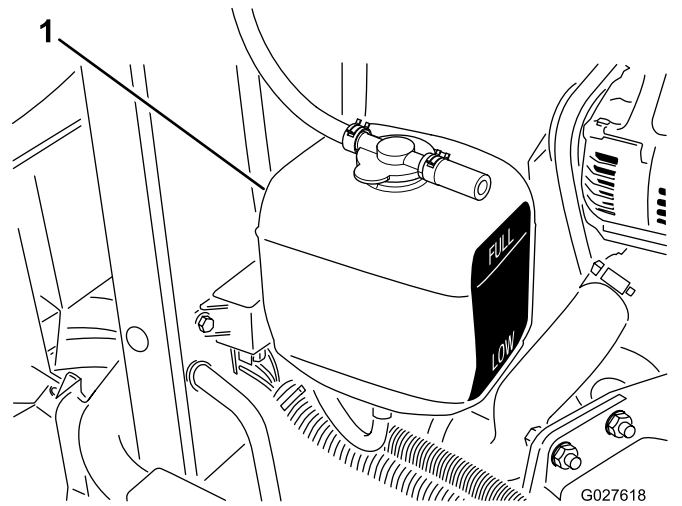

Figure 41

G027618

g027618

1. Expansion tank

Note: With a cold engine, the coolant level should be approximately midway between the marks on the side of the tank.

2. If the coolant level is low, remove the expansion tank cap and replenish the system. **Do not overfill.**
3. Install the expansion tank cap.

Checking the Hydraulic System

Service Interval: Before each use or daily—Check the level of the hydraulic fluid.

The hydraulic-fluid tank is filled at the factory with approximately 13.2 L (3.5 US gallons) of high-quality hydraulic fluid. **Check the level of the hydraulic fluid before the engine is first started and daily thereafter.**

The best time to check the hydraulic fluid is when the fluid is cold. The machine should be in its transport configuration. If the fluid level is below the Add mark on the dipstick, add fluid to bring the fluid level to the middle of the acceptable range. Do not overfill the tank. If the oil level is between the Full and the Add marks, no fluid addition is required.

The recommended replacement fluid is **Toro Premium All Season Hydraulic Fluid** (Available in 5-gallon pails or 55-gallon drums. Refer to the parts catalog or a Toro distributor for part numbers.)

Alternative fluids: If the Toro fluid is not available, other conventional, petroleum-based fluids may be used, provided that they meet all the following material properties and industry specifications. Check with your oil supplier to see whether the fluid meets these specifications.

Note: Toro will not assume responsibility for damage caused by improper substitutions, so use only products

from reputable manufacturers who will stand behind their recommendation.

High Viscosity Index/Low Pour Point Antiwear Hydraulic Fluid, ISO VG 46 Multigrade

Material Properties:

Viscosity, ASTM D445	cSt @ 40°C (104°F) 44 to 48 cSt @ 100°C (212°F) 7.9 to 9.1
Viscosity index, ASTM D2270	140 or higher (high viscosity index indicates a multiweight fluid)
Pour point, ASTM D97	-36.7°C to -45°C (-34°F to -49°F)
FZG, fail stage	11 or better
Water content (new fluid)	500 ppm (maximum)

Industry Specifications:

Vickers I-286-S, Vickers M-2950-S, Denison HF-0, Vickers 35 VQ 25 (Eaton ATS373-C)

The proper hydraulic fluids must be specified for mobile machinery (as opposed to industrial plant usage), multiweight-type, with ZnDTP or ZDDP anti-wear additive package (not an ashless-type fluid).

Important: Many hydraulic fluids are almost colorless, making it difficult to spot leaks. A red dye additive for the hydraulic system fluid is available in 20 ml (2/3 fl oz) bottles. One bottle is sufficient for 15 to 22 L (4 to 6 US gallons) of hydraulic fluid. Order Part No. 44-2500 from your Authorized Toro Distributor.

1. Park the machine on a level surface, lower the cutting units, shut off the engine, engage the parking brake, and remove the key from the ignition switch.
2. Clean the area around the filler neck and cap of the hydraulic-fluid tank (Figure 42) and remove the cap.

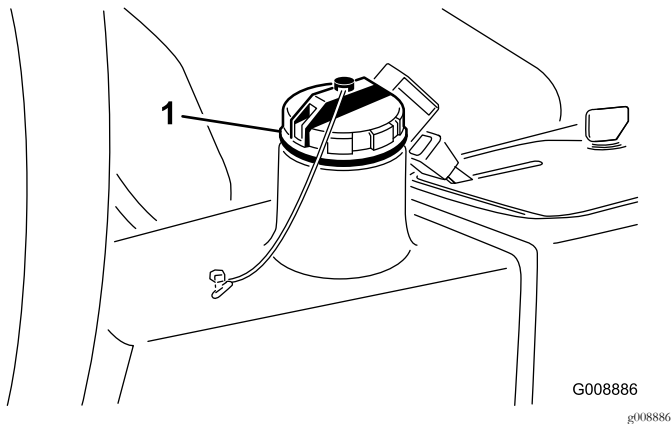

Figure 42

1. Hydraulic-fluid tank cap

3. Remove the dipstick from the filler neck and wipe it with a clean rag.
4. Insert the dipstick into the filler neck; then remove it and check the fluid level.

Note: The fluid level should be within 6 mm (1/4 inch) of the mark on the dipstick.

5. If the level is low, add the appropriate fluid to raise the level to the full mark.
6. Install the dipstick and cap onto the filler neck.

Checking the Tire Pressure

Service Interval: Before each use or daily

The tires are over-inflated for shipping. Therefore, release some of the air to reduce the pressure. The proper air pressure in the tires is 97 to 124 kPa (14 to 18 psi).

Note: Maintain the recommended pressure in all tires to ensure a good quality of cut and proper machine performance.

⚠ DANGER

Low tire pressure decreases machine side hill stability. This could cause a rollover, which may result in personal injury or death.

Do not under-inflate the tires.

Checking the Reel-to-Bedknife Contact

Service Interval: Before each use or daily

Check the reel-to-bedknife contact even if the quality of cut had been acceptable previously. There must be light contact across the full length of the reel and bedknife; refer to Adjusting Reel to Bedknife in the cutting unit operator's manual.

Torquing the Wheel Nuts

Service Interval: After the first hour

After the first 10 hours

Every 200 hours

Torque the wheel nuts to 61 to 88 N·m (45 to 65 ft-lb).

⚠ WARNING

Failure to maintain proper torque of the wheel nuts could result in personal injury.

Ensure that the wheel nuts are torqued to 61 to 88 N·m (45 to 65 ft-lb).

Starting and Shutting Off the Engine

You may need to bleed the fuel system if any of the following situations have occurred; refer to [Bleeding the Fuel System \(page 33\)](#):

- It is the initial startup of a new engine.
- The engine has ceased running due to lack of fuel.
- Maintenance has been performed upon the fuel system components; e.g., filter replaced, etc.

Starting the Engine

1. Ensure that the parking brake is engaged and the reel drive switch is in the DISENGAGE position.
2. Remove your foot from the traction pedal and ensure that the pedal is in the neutral position.
3. Move the throttle lever to the 1/2 throttle position.
4. Insert the key into the switch and rotate it to the ON/PREHEAT position until the glow plug indicator light goes out (approximately 7 seconds); then rotate the key to the START position to engage the starter motor. Release the key when the engine starts.

Note: The key moves automatically to the ON/RUN position.

Important: To prevent overheating of the starter motor, do not engage the starter longer than 15 seconds. After 10 seconds of continuous cranking, wait 60 seconds before engaging the starter motor again.

5. When the engine is started for the first time or after an overhaul of the engine, operate the machine in forward and reverse for 1 to 2 minutes. Also operate the lift lever and cutting unit drive switch to ensure proper operation of all parts.

Note: Turn the steering wheel to the left and right to check the steering response, then shut the engine off and check for oil leaks, loose parts, and any other noticeable malfunctions.

⚠ CAUTION

Checking for oil leaks, loose parts, and other malfunctions could result in injury.

Shut off the engine and wait for all moving parts to stop before checking for oil leaks, loose parts, and other malfunctions.

Shutting Off the Engine

Move the throttle control to the IDLE position, move the reel drive switch to DISENGAGE, and rotate the starter key to OFF.

Note: Remove the key from the switch to prevent accidental starting.

Bleeding the Fuel System

1. Park the machine on a level surface, lower the cutting units, shut off the engine, engage the parking brake, and remove the key from the ignition switch.

2. Ensure that the fuel tank is at least half full.
3. Unlatch and raise the hood.

⚠ DANGER

Under certain conditions, diesel fuel and fuel vapors are highly flammable and explosive. A fire or explosion from fuel can burn you and others and can cause property damage.

- Use a funnel and fill the fuel tank outdoors, in an open area, when the engine is off and is cold. Wipe up any spilled fuel.
- Do not fill the fuel tank completely full. Add fuel to the fuel tank until the level is 6 to 13 mm (1/4 to 1/2 inch) below the bottom of the filler neck. This empty space in the tank allows the fuel to expand.
- Never smoke when handling fuel, and stay away from an open flame or where fuel fumes may be ignited by a spark.
- Store fuel in a clean, safety-approved container and keep the cap in place.

4. Open the air bleed screw on the fuel-injection pump (Figure 43).

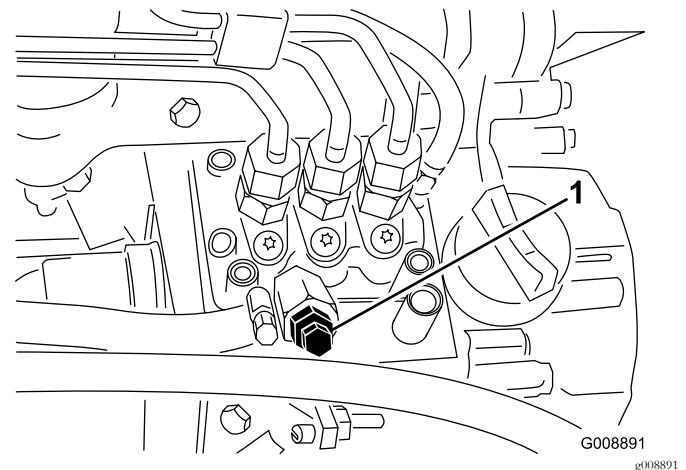

Figure 43

1. Fuel-injection pump bleed screw

5. Turn the key in the ignition switch to the ON position. The electric fuel pump begins operation, thereby forcing air out around the air bleed screw.

Note: Leave the key in the ON position until a solid stream of fuel flows out around the screw.

6. Tighten the screw and turn the key to off.

Note: Normally the engine should start after following the bleeding procedures above. However, if the engine does not start, air may be trapped between the injection pump and the injectors; refer to [Bleeding Air from the Injectors](#) (page 50).

Checking the Interlock System

Service Interval: Before each use or daily

⚠ CAUTION

If the safety interlock switches are disconnected or damaged, the machine could operate unexpectedly, causing personal injury.

- Do not tamper with the interlock switches.
 - Check the operation of the interlock switches daily and replace any damaged switches before operating the machine.
1. Ensure that all bystanders are away from the area of operation, and keep hands and feet away from the cutting units.
 2. While sitting on the seat, the engine must not start with either the cutting unit switch engaged or the traction pedal engaged. Correct the problem if it is not operating properly.
 3. While sitting on the seat, put the traction pedal in neutral, disengage the parking brake, and set the cutting unit switch in the OFF position. The engine should start. Rise from the seat and slowly press the traction pedal, and the engine should shut off in 1 to 3 seconds. Correct the problem if it is not operating properly.

Note: The machine is equipped with an interlock switch on the parking brake. The engine shuts off if you press the traction pedal with the parking brake engaged.

Identifying the Tie-Down Points

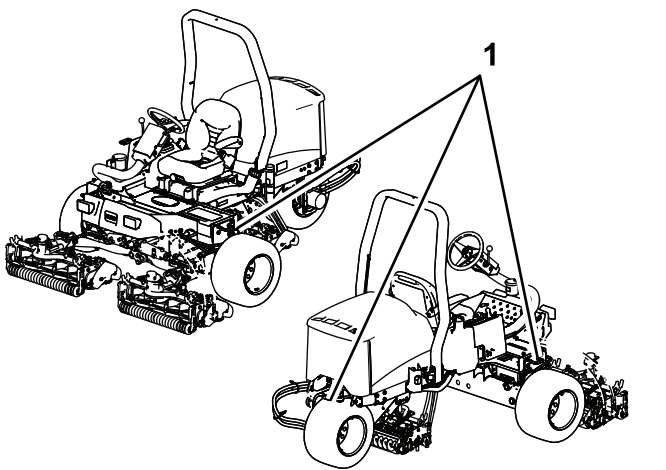

Figure 44

1. Tie-down loops

Hauling the Machine

- Use full-width ramps for loading the machine onto a trailer or truck.
- Tie the machine down securely.

Towing the Machine

In case of an emergency, the machine can be towed for a short distance; however, Toro does not recommend this as a standard procedure.

Important: Do not tow the machine faster than 3 to 4 km/h (2 to 3 mph) because it may damage the drive system. If the machine must be moved a considerable distance, transport it on a truck or trailer.

1. Locate the bypass valve on the pump (Figure 45) and rotate it 90°.

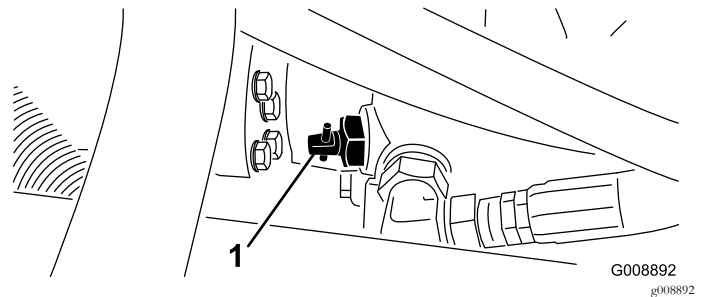

Figure 45

1. Bypass valve

2. Before starting the engine, close the bypass valve by rotating it 90° (1/4 turn). Do not start the engine while the valve is open.

Using the Standard Control Module (SCM)

The Standard Control Module is a potted electronic device produced in a one-size-fits-all configuration. The module uses solid state and mechanical components to monitor and control standard electrical features required for safe product operation.

The module monitors inputs including neutral, parking brake, PTO, start, backlap, and high temperature. The module energizes outputs including PTO, Starter, and ETR (energize to run) solenoid.

The module is divided into inputs and outputs. Inputs and outputs are identified by green LED indicators mounted on the printed circuit board.

The start circuit input is energized by 12 VDC. All other inputs are energized when the circuit is closed to ground. Each input has a LED that is illuminated when the specific circuit is energized. Use the input LEDs for switch and input circuit troubleshooting.

Output circuits are energized by an appropriate set of input conditions. The 3 outputs include PTO, ETR, and START. Output LEDs monitor relay condition indicating the presence of voltage at 1 of 3 specific output terminals.

Output circuits do not determine output device integrity, so electrical troubleshooting includes output LED inspection and conventional device and wire harness integrity testing. Measure the disconnected component impedance, the impedance through wire harness (disconnect at SCM), or by temporarily "test energizing" the specific component.

The SCM does not connect to an external computer or handheld device, cannot be re-programmed, and does not record intermittent fault troubleshooting data.

The decal on the SCM only includes symbols. Three LED output symbols are shown in the output box. All other LEDs are inputs. The chart below identifies the symbols.

product functions are listed in the left column. The symbols identify the specific circuit condition including: energized to voltage, closed to ground, and open to ground.

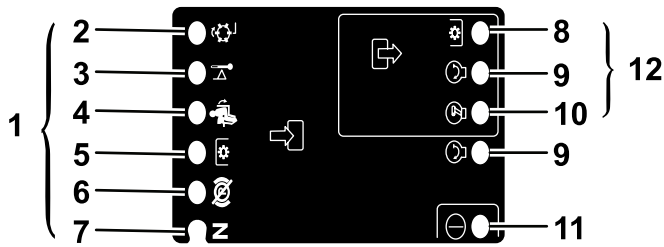

Figure 46

g190826

- | | |
|----------------------|-------------|
| 1. Inputs | 7. Neutral |
| 2. Backlap | 8. PTO |
| 3. High temperature | 9. Start |
| 4. In seat | 10. ETR |
| 5. PTO switch | 11. Power |
| 6. Parking brake off | 12. Outputs |

Here are the logical troubleshooting steps for the SCM device.

1. Determine the output fault you are trying to resolve (PTO, START, or ETR).
2. Move the key switch to the ON position and ensure that the red power LED is illuminated.
3. Move all the input switches to ensure that all LEDs change state.
4. Position the input devices at the appropriate position to achieve the appropriate output. Use the following logic chart to determine the appropriate input condition.
5. If the specific output LED is illuminated without the appropriate output function, check the output harness, connections, and component. Repair as needed.
6. If the specific output LED is not illuminated, check both fuses.
7. If the specific output LED is not illuminated and the inputs are in the appropriate condition, install a new SCM and determine if the fault disappears.

Each row (across) in the logic chart below identifies input and output requirements for each specific product function. The

INPUTS									OUTPUTS		
Function	Power ON	In Neutral	Start ON	Brake ON	PTO ON	In Seat	Hi Temp	Backlap	Start	ETR	PTO
Start	—	—	+	O	O	—	O	O	+	+	O
Run (Off Unit)	—	—	O	O	O	O	O	O	O	+	O
Run (On Unit)	—	O	O	—	O	—	O	O	O	+	O
Mow	—	O	O	—	—	—	O	O	O	+	+
Backlap	—	—	O	O	—	O	O	—	O	+	+
Hi Temp	—		O				—		O	O	O

- (–) Indicates a circuit closed to ground—LED ON.
- (O) Indicates a circuit open to ground or de-energized—LED OFF.
- (+) Indicates an energized circuit (clutch coil, solenoid, or start input)—LED ON.
- A blank indicates a circuit that is not involved with the logic.

To troubleshoot, turn on the key without starting the engine. Identify the specific function that does not work and work across the logic chart. Inspect the condition of each input LED's to ensure that it matches the logic chart.

If the input LEDs are correct, check the output LED. If the output LED is illuminated but the device is not energized, measure the available voltage at the output device, the continuity of the disconnected device, and the potential voltage on the ground circuit (floating ground). Repairs will vary depending on your findings.

Operating Tips

General Tips for Model 03171

▲ DANGER

The mower has a unique traction system that allows the machine to move forward on side hills, even if the uphill wheel should come off the ground. If this should happen, you or any bystanders could be seriously injured or killed in a rollover.

The slope angle at which the machine tips depends on many factors. Among these are mowing conditions such as wet or undulating turf, speed (especially in turns), position of the cutting units (with Sidewinder), tire pressure, and operator experience.

At side hill angles of 15 degrees or less, the risk of a rollover is low. As the slope angle increases to a recommended maximum limit of 25 degrees, the risk of a rollover increases to a moderate level. *Do not exceed a 20 degree side hill slope angle because the risk of a rollover and serious injury or death is very high.*

To determine which hills or slopes you may safely operate on, you must conduct a site survey of the mowing area. When performing this site survey, always use common sense and take into consideration the turf condition and the rollover risk. To determine which hills or slopes may be safely operated on, use the inclinometer provided with each machine. To perform a site survey, lay a 1.25 m plank (4 ft 2 x 4) on the slope surface and measure the angle of the slope. The 1.25 m plank (4 ft 2 x 4) averages the slope but does not take into consideration dips or holes, which can cause a sudden change in side hill angle. *The maximum side hill angle should not be greater than 20 degrees.*

Additionally, the machine is equipped with an angle indicator mounted on the steering tube. This indicates the side hill angle the machine is on and identifies the recommended maximum limit of 25 degrees.

- Practice operating the machine and become thoroughly familiar with it.
- Start the engine and run it at half idle until it warms up. Push the throttle lever all the way forward, lift the cutting units, disengage the parking brake, press the forward traction pedal, and carefully drive to an open area.
- Practice moving forward and in reverse, and starting and stopping the machine. To stop the machine, take your

foot off the traction pedal and let it return to neutral or press down on the reverse pedal to stop. Going down a hill, you may need to use the reverse pedal to stop.

- When driving on slopes, drive slowly to maintain steering control and avoid turns to prevent rollovers. In side hill situations you should shift the sidewinder cutting units to the uphill side to give you more stability. Conversely, shifting the cutting units to the down hill side will give you **less** stability. This should always be done **before** going on a side hill.
- When possible, mow up and down hills rather than across them. Have the cutting units lowered when going down a hill to maintain steering control. Do not attempt to turn on a hill.
- Practice driving around obstacles with the cutting units up and down. Be careful when driving between objects so that you do not damage the machine or cutting units.
- Get a feel for the reach of the cutting units so that you do not hang them up or damage them in any way.
- Do not shift the units from side to side, unless the cutting units are down and the machine is moving, or the cutting units are up in the transport position. Shifting the cutting units when they are down and the machine is not moving may damage the turf.
- Always drive slowly in rough areas.
- If a person appears in or near the operating area, stop the machine, and do not start it again until the area is cleared. The machine is designed for 1 person. Never let anyone else ride on the machine with you. This is extremely dangerous and could result in serious injury.
- Accidents can happen to anyone. The most common causes are excessive speed, sudden turns, terrain (not knowing which slopes and hills can be mowed safely), not stopping the engine before leaving the operator's seat, and drugs that impair your alertness. Cold capsules or prescription drugs may cause drowsiness, as can alcohol and other drugs. Stay alert and stay safe. Failure to do so could result in serious injury.
- Do not operate the mower if tired, ill, or under the influence of alcohol or drugs.
- The Sidewinder offers up to a maximum of 33 cm (13 inches) of overhang, allowing you to trim closer to the edge of sand traps and other obstacles, while at the same time keeping the tractor tires as far away from the edge of traps or water hazards as possible.
- If an obstacle is in the way, shift the cutting units to easily mow around it.
- When transporting the machine from 1 work area to another, raise the cutting units to the fully up position, move the mow/transport slide to the left to transport, and place the throttle in the FAST position.

General Tips for Model 03170

▲ DANGER

The mower has a unique traction system that allows the machine to move forward on side hills, even if the uphill wheel should come off the ground. If this should happen, you or any bystanders could be seriously injured or killed in a rollover.

The slope angle at which the machine tips depends on many factors. Among these are mowing conditions such as wet or undulating turf, speed (especially in turns), position of the cutting units, tire pressure, and operator experience.

At side hill angles of 20 degrees or less, the risk of a rollover is low. As the slope angle increases to a recommended maximum limit of 25 degrees, the risk of a rollover increases to a moderate level. ***Do not exceed a 25 degree side hill slope angle because the risk of a rollover and serious injury or death is very high.***

To determine which hills or slopes you may safely operate on, you must conduct a site survey of the mowing area. When performing this site survey, always use common sense and take into consideration the turf condition and the rollover risk. To determine which hills or slopes may be safely operated on, use the inclinometer provided with each machine. To perform a site survey, lay a 1.25 m plank (4 ft 2 x 4) on the slope surface and measure the angle of the slope. The 1.25 m plank (4 ft 2 x 4) averages the slope but does not take into consideration dips or holes, which can cause a sudden change in side hill angle. ***The maximum side hill angle should not be greater than 25 degrees.***

Additionally, the machine is equipped with an angle indicator mounted on the steering tube. This indicates the side hill angle the machine is on and identifies the recommended maximum limit of 25 degrees.

- When driving on slopes, drive slowly to maintain steering control and avoid turns to prevent rollovers.
 - When possible, mow up and down hills rather than across them. Have the cutting units lowered when going down a hill to maintain steering control. Do not attempt to turn on a hill.
 - Practice driving around obstacles with the cutting units up and down. Be careful when driving between objects so that you do not damage the machine or cutting units.
 - Get a feel for the reach of the cutting units so that you do not hang them up or damage them in any way.
 - Always drive slowly in rough areas.
 - If a person appears in or near the operating area, stop the machine, and do not start it again until the area is cleared. The machine is designed for 1 person. Never let anyone else ride on the machine with you. This is extremely dangerous and could result in serious injury.
 - Accidents can happen to anyone. The most common causes are excessive speed, sudden turns, terrain (not knowing which slopes and hills can be mowed safely), not stopping the engine before leaving the operator's seat, and drugs that impair your alertness. Cold capsules or prescription drugs may cause drowsiness, as can alcohol and other drugs. Stay alert and stay safe. Failure to do so could result in serious injury.
 - Do not operate the mower if tired, ill, or under the influence of alcohol or drugs.
 - When transporting the machine from 1 work area to another, raise the cutting units to the fully up position, move the mow/transport slide to the left to transport, and place the throttle in the FAST position.
- Practice operating the machine and become thoroughly familiar with it.
 - Start the engine and run it at half idle until it warms up. Push the throttle lever all the way forward, lift the cutting units, disengage the parking brake, press the forward traction pedal, and carefully drive to an open area.
 - Practice moving forward and reverse, and starting and stopping the machine. To stop the machine, take your foot off the traction pedal and let it return to neutral or press down on the reverse pedal to stop. Going down a hill, you may need to use the reverse pedal to stop.

Mowing Techniques

- To begin cutting, engage the cutting units, then approach the mowing area slowly. Once the front cutting units are over the mowing area, lower the cutting units.
- To achieve the professional straight-line cut and striping that is desirable for some applications, find a tree or other object in the distance and drive straight toward it.
- As soon as the front cutting units reach the edge of the mowing area, lift the cutting units and perform a tear drop shaped turn to quickly line you up for your next pass.
- To mow around bunkers, ponds, or other contours easily, use the Sidewinder and move the control lever left or right, depending on your mowing application. The cutting units can also be shifted to vary tire tracking.
- The cutting units tend to throw grass to the front or the rear of the machine. Front throw should be used when cutting smaller amounts of grass; thus, leaving a better after-cut appearance. To throw clippings to the front, simply close the rear shield on the cutting units.

⚠ CAUTION

To prevent personal injury or damage to the machine, do not open or close the cutting unit shields while the engine is running.

Shut off the engine and wait for all moving parts to stop before opening or closing the cutting unit shields.

- When cutting larger amounts of grass, position the shields to just below horizontal. **Do not open the shields too far or an excessive amount of clippings could build up on the frame, rear radiator screen, and engine area.**
- The cutting units are also equipped with balance weights on the non-motor end to give an even cut. You can add or remove weights if a mismatch occurs on your turf.

After Mowing

After mowing, thoroughly wash the machine with a garden hose without a nozzle to prevent excessive water pressure from prevent contamination and damage to the seals and bearings. Ensure that the radiator and oil cooler are kept free of dirt or grass clippings. After cleaning, inspect the machine for possible hydraulic fluid leaks, damage, or wear to the hydraulic and mechanical components. Check the cutting unit blades to ensure that they are sharp and that the reel-to-bedknife contact is properly adjusted.

Important: After washing the machine, move the Sidewinder mechanism from left to right several times to remove the water between the bearing blocks and the cross tube (Model 03171 only).

Selecting the Clip Rate (Reel Speed)

To achieve a consistent, high quality of cut and a uniform after-cut appearance, it is important that the reel speed be matched to the height of cut.

Important: If the reel speed is too slow, you may notice visible clip marks. If the reel speed is too fast, the cut may have a fuzzy appearance.

Adjust the clip rate (reel speed) as follows:

1. Verify the height-of-cut setting on the cutting units. Use the column of the chart listing either 5 or 8 reels, and find the height-of-cut listing nearest the actual height-of-cut setting. Look across the chart to find the number that corresponds to that height of cut.

REEL SPEED SELECTION CHART							
Height of Cut		5-Blade Reel		8-Blade Reel		11-Blade Reel	
		8 km/h (5 mph)	9.6 km/h (6 mph)	8 km/h (5 mph)	9.6 km/h (6 mph)	8 km/h (5 mph)	9.6 km/h (6 mph)
63.5 mm	2-1/2 inches	3	3	3*	3*	—	—
60.3 mm	2-3/8 inches	3	4	3*	3*	—	—
57.2 mm	2-1/4 inches	3	4	3*	3*	—	—
54.0 mm	2-1/8 inches	3	4	3*	3*	—	—
50.8 mm	2 inches	3	4	3*	3*	—	—
47.6 mm	1-7/8 inches	4	5	3*	3*	—	—
44.5 mm	1-3/4 inches	4	5	3*	3*	—	—
41.3 mm	1-5/8 inches	5	6	3*	3*	—	—
38.1 mm	1-1/2 inches	5	7	3	4	—	—
34.9 mm	1-3/8 inches	5	8	3	4	—	—
31.8 mm	1-1/4 inches	6	9	4	4	—	—
28.8 mm	1-1/8 inches	8	9*	4	5	—	—
25. mm	1 inch	9	9*	5	6	—	—
22.2 mm	7/8 inch	9*	9*	5	7	—	—
19.1 mm	3/4 inch	9*	9*	7	9	6	7
15.9 mm	5/8 inch	9*	9*	9	9*	7	7
12.7 mm	1/2 inch	9*	9*	9	9*	8	8
9.5 mm	3/8 inch	9*	9*	9	9*	9	9

* Toro does not recommend this height of cut and/or mowing speed.

Note: The higher the number, the higher the speed.

- Turn the reel speed control knob (Figure 47) to the number setting determined in Step 1.

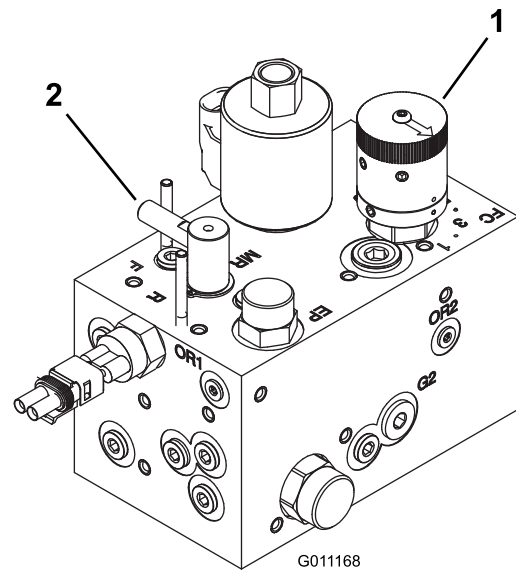

Figure 47

- Reel speed control
- Backlap control

- Operate the machine for several days, then examine the cut to ensure the quality of cut. The reel speed knob may be set 1 position on either side of the position indicated on the chart to account for differences in

grass condition, grass length removed, and personal preference.

Maintenance

Note: Determine the left and right sides of the machine from the normal operating position.

Recommended Maintenance Schedule(s)

Maintenance Service Interval	Maintenance Procedure
After the first hour	<ul style="list-style-type: none"> • Torque the wheel nuts.
After the first 10 hours	<ul style="list-style-type: none"> • Torque the wheel nuts. • Check the condition and tension of all belts. • Change the hydraulic filter.
After the first 50 hours	<ul style="list-style-type: none"> • Change the oil and the oil filter.
Before each use or daily	<ul style="list-style-type: none"> • Check the engine-oil level. • Check the engine-coolant level. • Check the level of the hydraulic fluid. • Check the tire pressure. • Check the reel-to-bedknife contact. • Check the interlock system. • Drain the water separator. • Clean the radiator and oil cooler. • Check the hydraulic lines and hoses.
Every 25 hours	<ul style="list-style-type: none"> • Check the electrolyte level. (If machine is in storage, check every 30 days.)
Every 50 hours	<ul style="list-style-type: none"> • Lubricate all bearings and bushings (lubricate all bearings and bushings daily when conditions are dusty and dirty).
Every 100 hours	<ul style="list-style-type: none"> • Check the condition and tension of all belts.
Every 150 hours	<ul style="list-style-type: none"> • Change the oil and the oil filter.
Every 200 hours	<ul style="list-style-type: none"> • Torque the wheel nuts. • Service the air cleaner (more frequently in extreme dusty or dirty conditions). • Check the parking brake adjustment. • Change the hydraulic filter.
Every 400 hours	<ul style="list-style-type: none"> • Check the fuel lines and connections. • Replace the fuel filter canister. • Change the hydraulic fluid.
Every 500 hours	<ul style="list-style-type: none"> • Grease the bearings in the rear axle.
Every 2 years	<ul style="list-style-type: none"> • Drain and clean the fuel tank. • Drain and flush the coolant system (take the machine to an Authorized Service Dealer or Distributor or refer to the Service Manual).

▲ CAUTION

If you leave the key in the ignition switch, someone could accidentally start the engine and seriously injure you or bystanders.

Remove the key from the ignition before you do any maintenance.

Daily Maintenance Checklist

Duplicate this page for routine use.

Maintenance Check Item	For the week of:						
	Mon.	Tues.	Wed.	Thurs.	Fri.	Sat.	Sun.
Check the safety interlock operation.							
Check the brake operation.							
Check the fuel level.							
Check the engine-oil level.							
Check the cooling system fluid level.							
Drain the water/fuel separator.							
Check the air filter, dust cup, and burp valve.							
Check for unusual engine noises. ²							
Check the radiator and screen for debris							
Check for unusual operating noises.							
Check the hydraulic system oil level.							
Check the hydraulic hoses for damage.							
Check for fluid leaks.							
Check the fuel level.							
Check the tire pressure.							
Check the instrument operation.							
Check the reel-to-bedknife contact adjustment.							
Check the height-of-cut adjustment.							
Lubricate all the grease fittings. ²							
Touch-up any damaged paint.							
¹ Check the glow plug and injector nozzles if starting is hard, there is excess smoke, or rough running is noted. ² Immediately after every washing, regardless of the interval listed.							

Important: Refer to your engine operator's manual for additional maintenance procedures.

Note: To obtain an electrical schematic or a hydraulic schematic for your machine, visit www.Toro.com.

Notation for Areas of Concern

Inspection performed by:		
Item	Date	Information

Service Interval Chart

REELMASTER 3100-D

QUICK REFERENCE AID

CHECK/SERVICE (DAILY)

- OIL LEVEL, ENGINE
- ENGINE OIL DRAIN (3/4" OR 19mm SOCKET)
- OIL LEVEL, HYDRAULIC TANK
- COOLANT LEVEL, RADIATOR
- FUEL/WATER SEPARATOR
- AIR CLEANER
- RADIATOR SCREEN
- PARKING BRAKE
- TIRE PRESSURE (14-18 psi)
- BATTERY
- BELTS (FAN, ALTERNATOR, HYDRAULIC PUMP)
- REEL SPEED & BACKLAP CONTROL

GREASING - SEE OPERATOR'S MANUAL

FUSES

MAIN	15A
MAX OPTIONAL LIGHT	15A
SYSTEM GAUGES SCV PTO	10A
START	10A
SCV	2A

FLUID SPECIFICATIONS/CHANGE INTERVALS

SEE OPERATOR'S MANUAL FOR INITIAL CHANGES.	FLUID TYPE	CAPACITY	CHANGE INTERVAL		FILTER PART NO.
			FLUID	FILTER	
A. ENGINE OIL	SAE 15W-40 CH-4	4.0 QTS.*	150 HRS.	150 HRS.	108-3841
B. HYD. CIRCUIT OIL	ISO VG 46/68	6 GAL.*	400 HRS.	200 HRS.	54-0110
C. AIR CLEANER				200 HRS.	108-3811
D. WATER SEPARATOR				400 HRS.	110-9049
E. FUEL TANK	NO. 2-DIESEL	7.5 GALS.	DRAIN AND FLUSH, 2 YRS.		
F. COOLANT	50/50 ETHYLENE GLYCOL/WATER	6 QTS.	DRAIN AND FLUSH, 2 YRS.		

Filter Size	5 mph / 8 kph		6 mph / 10 kph		5 mph / 8 kph		6 mph / 10 kph	
	5 mph / 8 kph	6 mph / 10 kph	5 mph / 8 kph	6 mph / 10 kph	5 mph / 8 kph	6 mph / 10 kph	5 mph / 8 kph	6 mph / 10 kph
1 1/2" (64mm)	3	3	3	3				
2 1/4" (60mm)	3	4	3	3				
2 1/2" (57mm)	3	4	3	3				
2 1/2" (54mm)	3	4	3	3				
2" (51mm)	3	4	3	3				
1 1/2" (48mm)	4	5	3	3				
1 1/2" (44mm)	4	5	3	3				
1 1/2" (41mm)	5	6	3	3				
1 1/2" (38mm)	5	7	3	4				
1 1/2" (35mm)	5	8	3	4				
1 1/2" (32mm)	6	9	4	4				
1 1/2" (29mm)	8	9	4	5				
1" (25mm)	9	9	5	6				
7/8" (22mm)	9	9	5	7				
9/16" (19mm)	9	9	7	9	6	7		
1/2" (16mm)	9	9	9	9	7	7		
1/2" (13mm)	9	9	9	9	8	8		
1/2" (10mm)	9	9	9	9	9	9		

121-3607

Figure 48

deca121-3607

Pre-Maintenance Procedures

Removing the Hood

The hood may be easily removed to ease maintenance procedures in the engine area of the machine.

1. Unlatch and raise the hood.
2. Remove the cotter pin that secures the hood pivot to the mounting brackets (Figure 49).

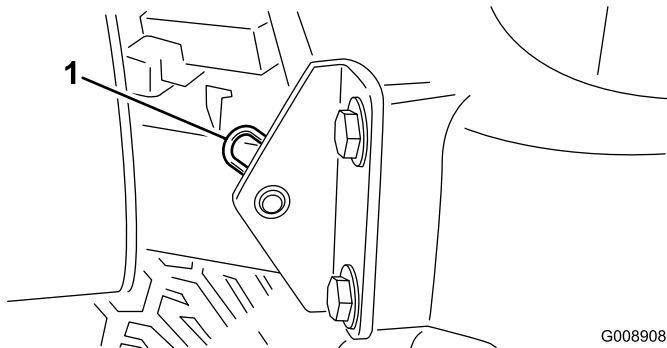

Figure 49

1. Cotter pin

3. Slide the hood to the right side, lift the other side, and pull it out of the brackets.

Note: Reverse the procedure to install the hood.

Lubrication

Greasing the Bearings And Bushings

Service Interval: Every 50 hours (lubricate all bearings and bushings daily when conditions are dusty and dirty).

Every 500 hours/Yearly (whichever comes first)

The machine has grease fittings that must be lubricated regularly with No. 2 lithium grease. Lubricate the bearings and bushings daily when the operating conditions are extremely dusty and dirty. Dusty and dirty operating conditions could cause dirt to get into the bearings and bushings, resulting in accelerated wear. Lubricate the grease fittings immediately after every washing, regardless of the interval specified.

The grease fitting locations and quantities are as follows:

- Rear cutting unit pivot (Figure 50)

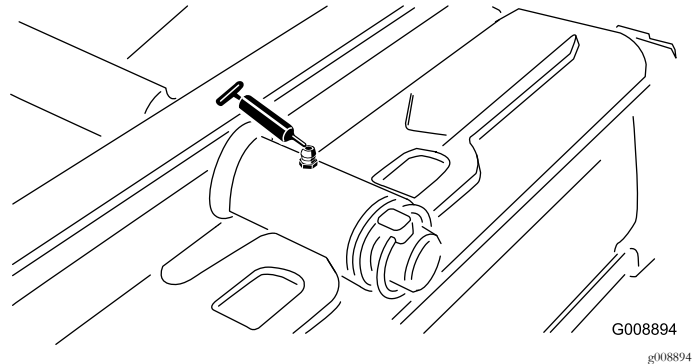

Figure 50

- Front cutting unit pivot (Figure 51)

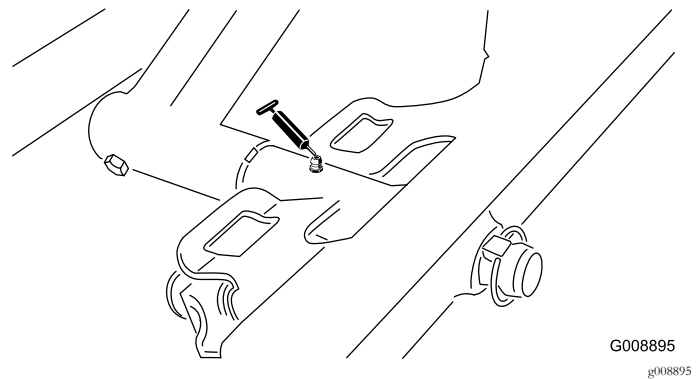

Figure 51

- SideWinder cylinder ends (2; Model 03171 only) (Figure 52)

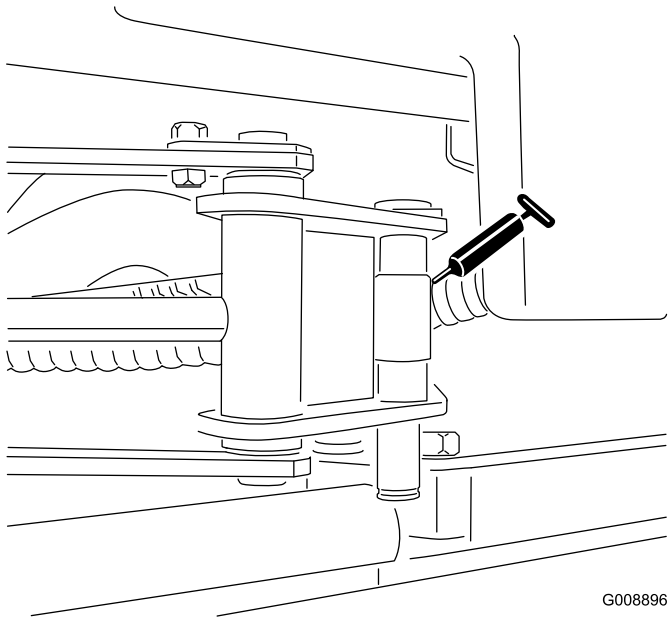

Figure 52

G008896
g008896

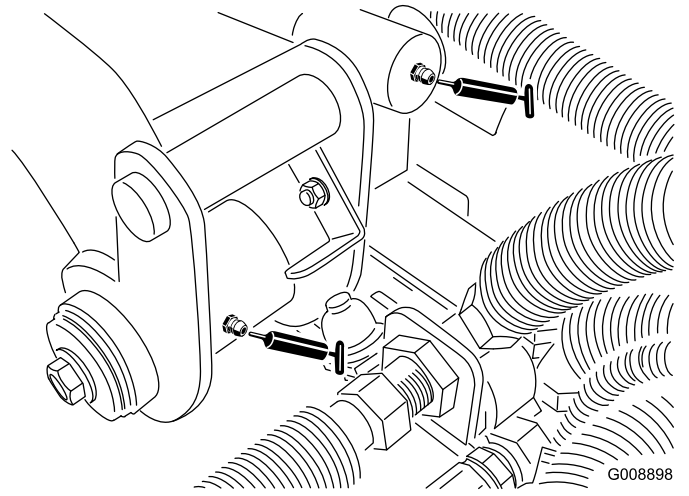

Figure 54

G008898
g008898

- Left front lift arm pivot and lift cylinder (2) (Figure 55)

- Steering pivot (Figure 53)

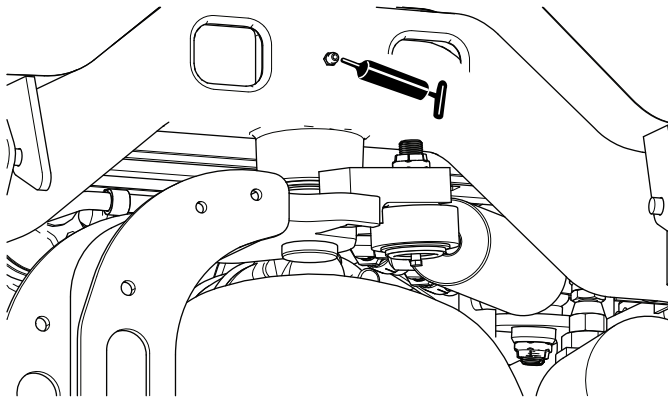

Figure 53

g190873

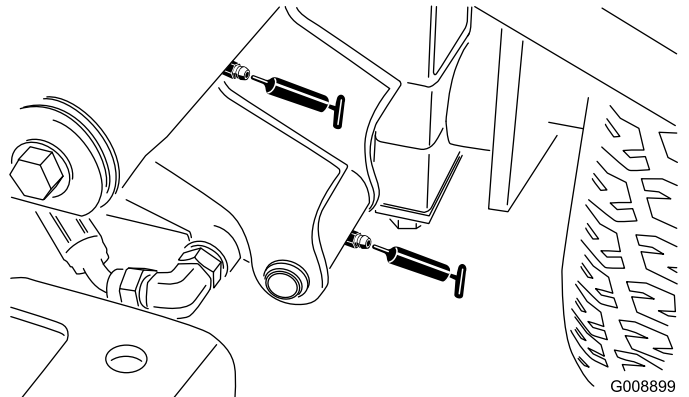

Figure 55

G008899
g008899

- Right front lift arm pivot and lift cylinder (2) (Figure 56)

- Rear lift arm pivot and lift cylinder (2) (Figure 54)

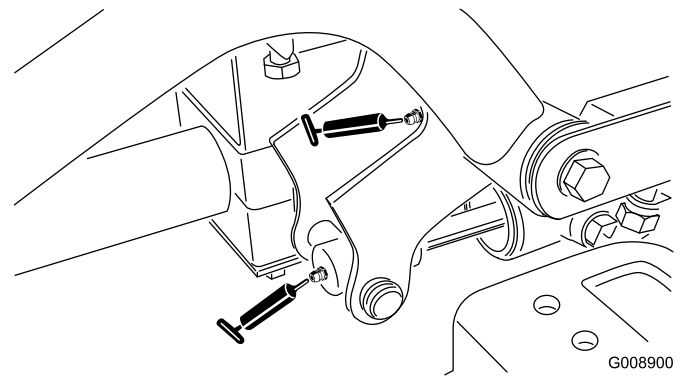
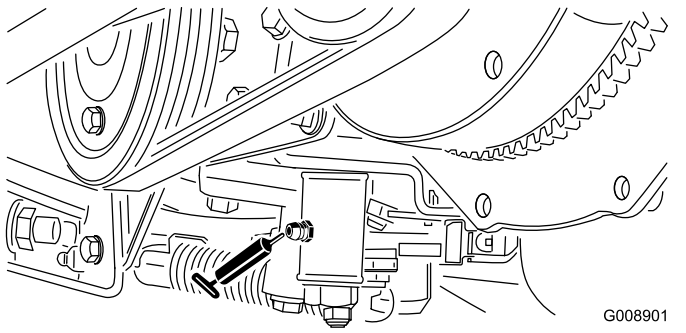

Figure 56

G008900
g008900

- Neutral adjust mechanism (Figure 57)



G008901
g008901

Figure 57

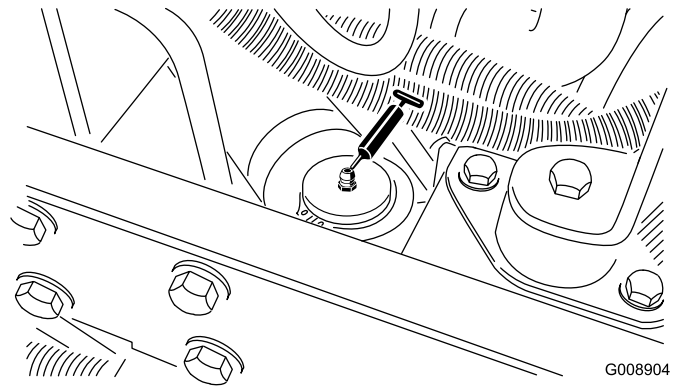

G008904
g008904

Figure 60

- Mow/transport slide (Figure 58)

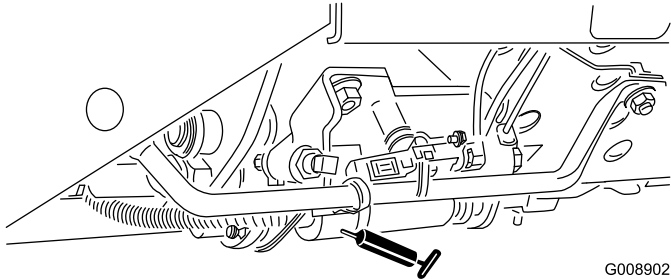

G008902
g008902

Figure 58

Note: If desired, install an additional grease fitting in the other end of the steering cylinder. Remove the tire, install the fitting, grease the fitting, remove the fitting, and install the plug (Figure 61).

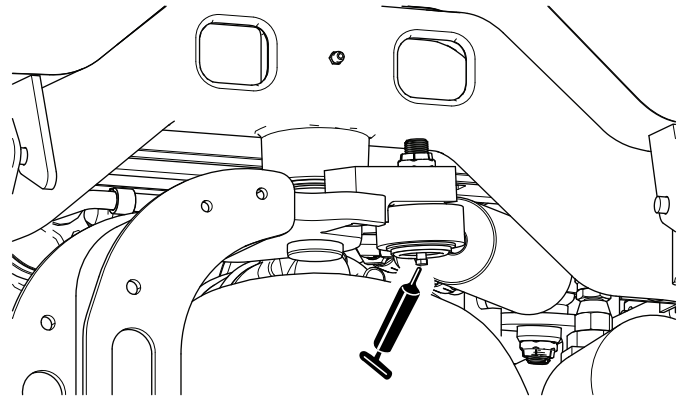

g190872

Figure 61

- Belt tension pivot (Figure 59)

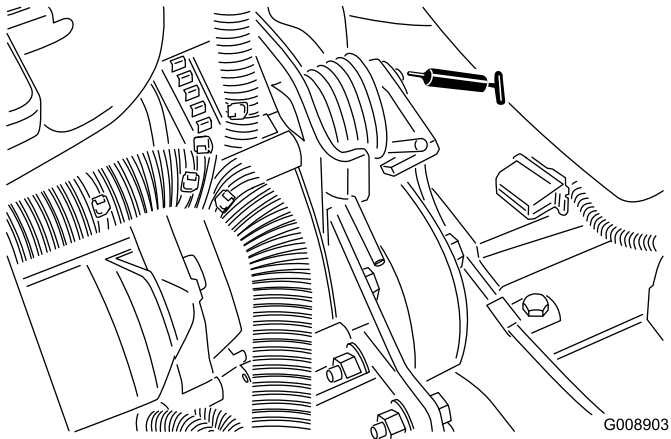

G008903
g008903

Figure 59

- Steering cylinder (Figure 60).

Checking the Sealed Bearings

Bearings rarely fail from defects in materials or workmanship. The most common reason for failure is moisture and contamination working its way past the protective seals. Bearings that are greased rely upon regular maintenance to purge harmful debris from the bearing area. **Sealed** bearings rely on an initial fill of special grease and a robust integral seal to keep contaminants and moisture out of the rolling elements.

The sealed bearings require no lubrication or short-term maintenance. This minimizes routine service required and reduces the potential of turf damage due to grease contamination. These sealed bearing packages will provide good performance and life under normal use, but periodic inspections of bearing condition and seal integrity should be conducted to avoid downtime. These bearings should be inspected seasonally and replaced if they are damaged or worn. Bearings should operate smoothly with no detrimental characteristics such as high heat, noise, looseness, or indications of corrosion (rust).

Due to the operating conditions these bearing/seal packages are subject to (i.e., sand, turf chemicals, water, impacts, etc.) they are considered normal wear items. Bearings that fail due to causes other than defects in materials or workmanship are typically not covered under the warranty.

Note: Bearing life can be negatively affected by improper wash-down procedures. Do not wash down the machine when it is still hot and avoid directing high-pressure or high-volume spray at the bearings.

Engine Maintenance

Servicing the Air Cleaner

Service Interval: Every 200 hours (more frequently in extreme dusty or dirty conditions).

- Check the air cleaner body for damage which could cause an air leak. Replace it if it is damaged. Check the whole intake system for leaks, damage, or loose hose clamps.
 - Service the air cleaner at the recommended service interval or earlier if engine performance suffers due to extremely dusty, dirty conditions. Changing the air filter before it is necessary only increases the chance of dirt entering the engine when the filter is removed.
 - Ensure that the cover is seated correctly and seals with the air-cleaner body.
1. Release the latches that secure the air-cleaner cover to the air-cleaner body (Figure 62).

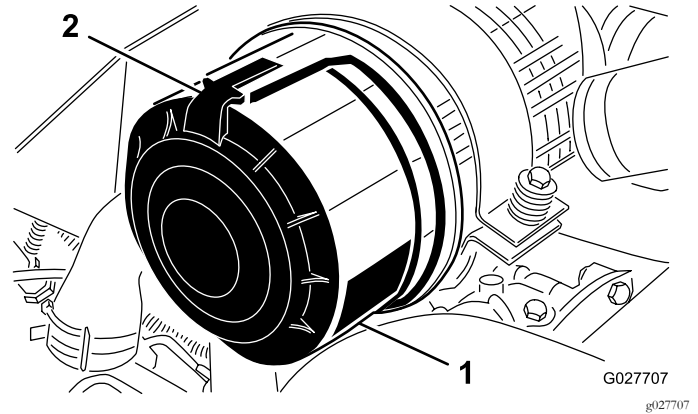

Figure 62

1. Air-cleaner cover
2. Air-cleaner latch

2. Remove the cover from the air-cleaner body.
3. Before removing the filter, use low-pressure air—276 kPa (40 psi), clean and dry—to help remove large accumulations of debris packed between the outside of primary filter and the canister. Avoid using high-pressure air which could force dirt through the filter into the intake tract. This cleaning process prevents debris from migrating into the intake when you remove the primary filter.
4. Remove and replace the primary filter (Figure 63).

Note: Cleaning the used element may damage the filter media.

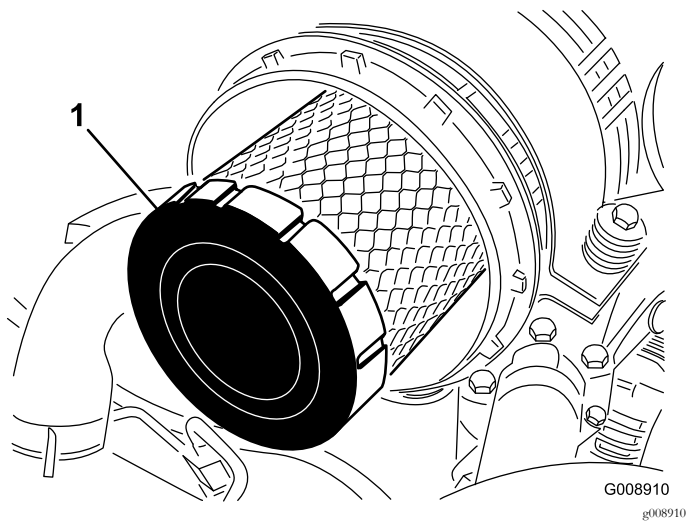

Figure 63

1. Primary filter

5. Inspect the new filter for shipping damage and check the sealing end of the filter and the body. **Do not use a damaged element.**
6. Insert the new filter by applying pressure to the outer rim of the element to seat it in the canister. **Do not apply pressure to the flexible center of the filter.**
7. Clean the dirt ejection port located in the removable cover.
8. Remove the rubber outlet valve from the cover, clean the cavity, and replace the outlet valve.
9. Install the cover orienting the rubber outlet valve in a downward position—between approximately 5 o'clock to 7 o'clock when viewed from the end.
10. Secure the cover latches.

Changing the Engine Oil and the Filter

Service Interval: After the first 50 hours

Every 150 hours

1. Remove either drain plug ([Figure 64](#)) and let the oil flow into a drain pan; when the oil stops flowing, install the drain plug.

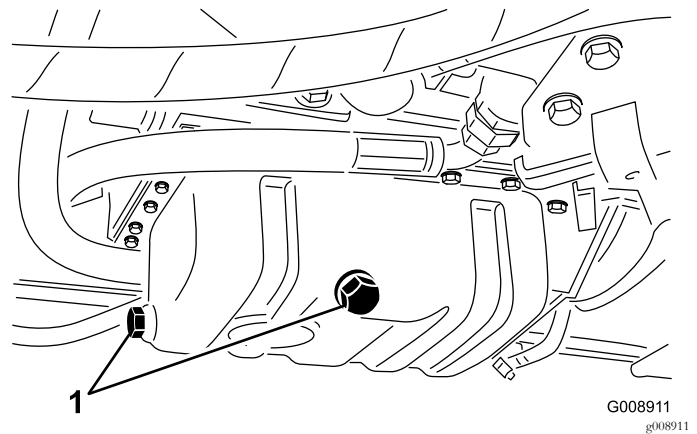

Figure 64

1. Drain plugs

2. Remove the oil filter ([Figure 65](#)).

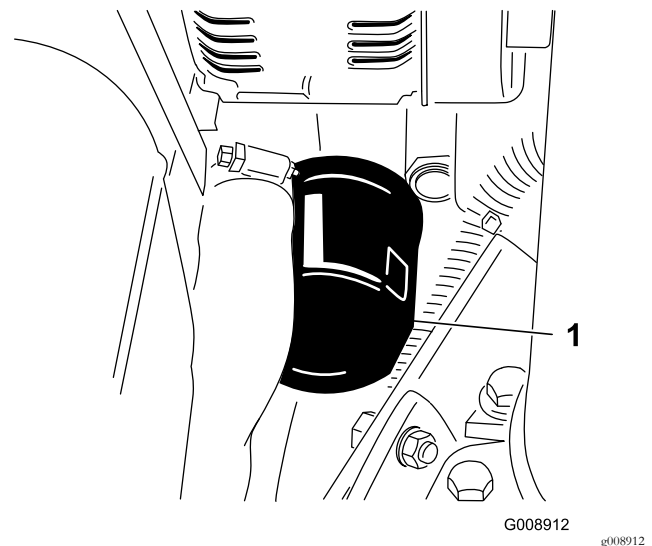

Figure 65

1. Oil filter

3. Apply a light coat of clean oil to the new filter seal and install the oil filter.

Note: Do not overtighten the filter.

4. Add oil to the crankcase; refer to [Checking the Engine-Oil Level](#) (page 29).

Fuel System Maintenance

⚠ DANGER

Under certain conditions, diesel fuel and fuel vapors are highly flammable and explosive. A fire or an explosion from fuel can burn you and others and can cause property damage.

- Use a funnel and fill the fuel tank outdoors, in an open area, when the engine is off and is cold. Wipe up any fuel that spills.
- Do not fill the fuel tank completely full. Add fuel to the fuel tank until the level is 6 to 13 mm (1/4 to 1/2 inch) below the bottom of the filler neck. This empty space in the tank allows the fuel to expand.
- Never smoke when handling fuel, and stay away from an open flame or where fuel fumes may be ignited by a spark.
- Store fuel in a clean, safety-approved container, and keep the cap in place.

Servicing the Fuel Tank

Service Interval: Every 2 years—Drain and clean the fuel tank.

Drain and clean the tank if the fuel system becomes contaminated or if the machine will be stored for an extended period of time. Use clean fuel to flush out the tank.

Inspecting the Fuel Lines and Connections

Service Interval: Every 400 hours/Yearly (whichever comes first)

Inspect the fuel lines and connections for deterioration, damage, or loose connections.

Draining the Water Separator

Service Interval: Before each use or daily

1. Place a clean container under the fuel filter.
2. Loosen the drain valve on the bottom of the filter canister ([Figure 66](#)).

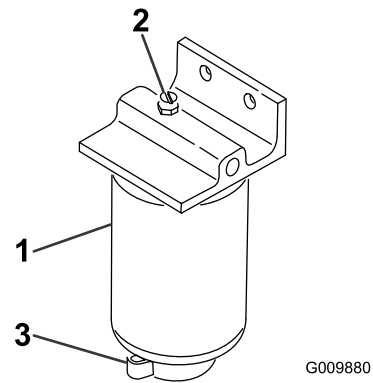

Figure 66

1. Water separator/filter canister
2. Vent plug
3. Drain valve

3. Tighten the valve after draining.

Changing the Fuel Filter Canister

Service Interval: Every 400 hours

1. Clean the area where the filter canister mounts ([Figure 66](#)).
2. Remove the filter canister and clean the mounting surface.
3. Lubricate the gasket on the filter canister with clean oil.
4. Install the filter canister by hand until the gasket contacts the mounting surface; then rotate an additional 1/2 turn.

Bleeding Air from the Injectors

Note: Perform this procedure only when the fuel system has been purged of air through normal priming procedures and the engine does not start; refer to [Bleeding the Fuel System](#) ([page 33](#)).

1. Loosen the pipe connection to the #1 nozzle and holder assembly.

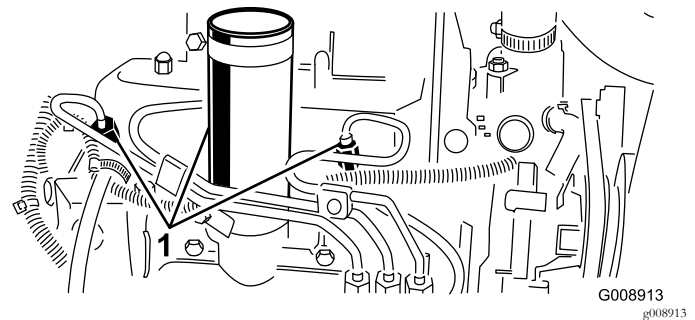

Figure 67

1. Fuel injectors

2. Move the throttle to the FAST position.
3. Turn the key in the key switch to the START position and watch the fuel flow around the connector. Turn the key to the OFF position when you see a solid flow.
4. Tighten the pipe connector securely.
5. Repeat this procedure on the remaining nozzles.

Electrical System Maintenance

Caring for the Battery

Service Interval: Every 25 hours—Check the electrolyte level. (If machine is in storage, check every 30 days.)

WARNING

CALIFORNIA Proposition 65 Warning

Battery posts, terminals, and related accessories contain lead and lead compounds, chemicals known to the State of California to cause cancer and reproductive harm.

Wash hands after handling.

The battery electrolyte level must be properly maintained and the top of the battery kept clean. If the machine is stored in a location where temperatures are extremely high, the battery will run down more rapidly than if the machine is stored in a location where temperatures are cool.

⚠ DANGER

Battery electrolyte contains sulfuric acid which is a deadly poison and causes severe burns.

- **Do not drink electrolyte and avoid contact with skin, eyes or clothing. Wear safety glasses to shield your eyes and rubber gloves to protect your hands.**
- **Fill the battery where clean water is always available for flushing the skin.**
- **Charge the battery in a well-ventilated place so that the gasses produced while charging can dissipate.**
- **Since the gases are explosive, keep open flames and electrical sparks away from the battery; do not smoke.**
- **Nausea may result if the gases are inhaled.**
- **Unplug the charger from the electrical outlet before connecting to or disconnecting the charger leads from the battery posts.**

Maintain the cell level with distilled or demineralized water. Do not fill the cells above the bottom of the split ring inside each cell. Install the filler caps with the vents pointing to the rear (toward the fuel tank).

Keep the top of the battery clean by washing it periodically with a brush dipped in ammonia or bicarbonate of soda

solution. Flush the top surface with water after cleaning. Do not remove the filler caps while cleaning.

The battery cables must be tight on the terminals to provide good electrical contact.

⚠ WARNING

Incorrect battery cable routing could damage the tractor and cables causing sparks. Sparks can cause the battery gasses to explode, resulting in personal injury.

- Always **disconnect the negative (black) battery cable before disconnecting the positive (red) cable.**
- Always **connect the positive (red) battery cable before connecting the negative (black) cable.**

If corrosion occurs at the terminals, disconnect the cables, negative (–) cable first, and scrape the clamps and terminals separately. Connect the cables, positive (+) cable first, and coat the terminals with petroleum jelly.

Important: Always disconnect the battery cables, ground cable (–) first, to prevent possible wiring damage from short outs whenever working with the electrical system.

Storing the Battery

If the machine will be stored more than 30 days, remove the battery and charge it fully. Either store it on the shelf or on the machine. Leave the cables disconnected if they are stored on the machine. Store the battery in a cool atmosphere to avoid quick deterioration of the charge in the battery. To prevent the battery from freezing, ensure that it is fully charged. The specific gravity of a fully charged battery is 1.265 to 1.299.

Checking the Fuses

The fuses are located under the console cover of the machine.

Drive System Maintenance

Adjusting the Traction Drive for Neutral

If the machine moves when the traction pedal is in the neutral position, adjust the traction cam.

1. Park the machine on a level surface, lower the cutting units, shut off the engine, engage the parking brake, and remove the key from the ignition switch.
2. Raise 1 front wheel and 1 rear wheel off the floor and place support blocks under the frame.

Note: 1 front wheel and rear wheel must be raised off the ground or the machine will move during the adjustment.

3. Loosen locknut on traction adjustment cam (Figure 68).

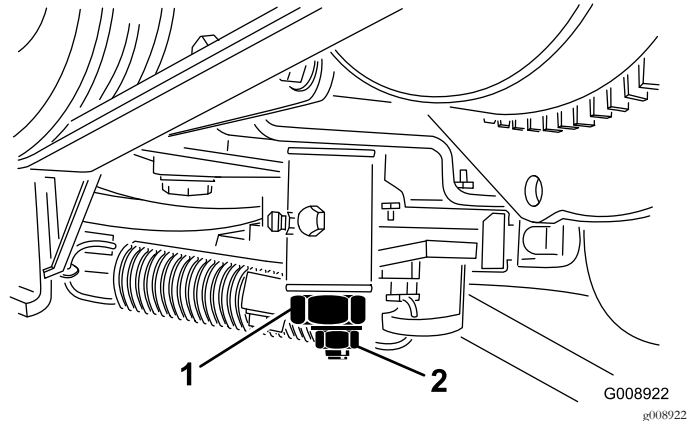

Figure 68

1. Traction adjustment cam
2. Locknut

4. Start the engine and rotate the cam hex in both directions to determine mid-position of neutral span.
5. Tighten the locknut that secures the adjustment.
6. Shut off the engine.
7. Remove the support blocks and lower the machine to the shop floor. Test drive the machine to ensure that it does not creep.

Cooling System Maintenance

Cleaning the Engine Cooling System

Service Interval: Before each use or daily

Remove debris from the oil cooler and radiator daily. Clean them more frequently in dirty conditions.

1. Park the machine on a level surface, lower the cutting units, shut off the engine, engage the parking brake, and remove the key from the ignition switch.
2. Raise the hood.
3. Clean the engine area thoroughly of all debris.
4. Remove the access panel.
5. Clean both sides of the radiator area thoroughly with water or compressed air (Figure 69).

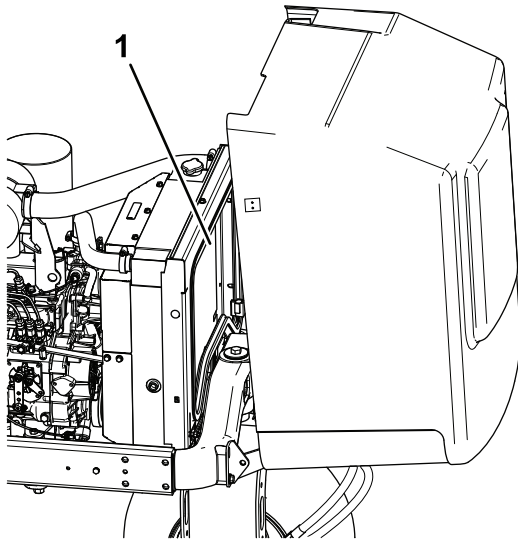

Figure 69

1. Radiator

-
6. Install the access panel and close the hood.

Brake Maintenance

Adjusting the Parking Brake

Service Interval: Every 200 hours—Check the parking brake adjustment.

1. Loosen the set screw that secures the knob to the parking brake lever (Figure 70).

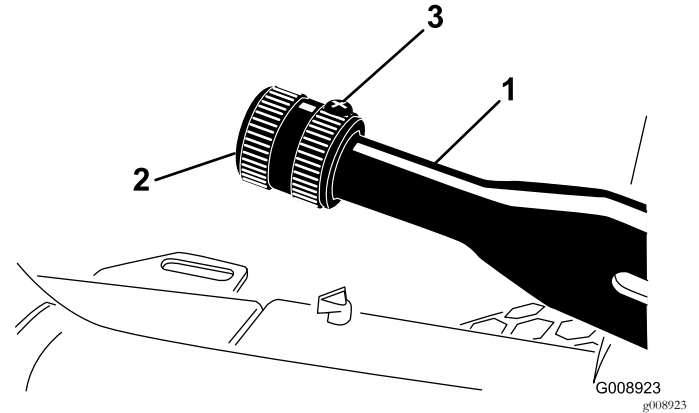

Figure 70

1. Parking brake lever
2. Knob
3. Set screw

-
2. Rotate the knob until you produce a force of 41 to 68 N·m (30 to 40 ft-lb) needed to actuate the lever.
 3. Tighten the set screw after attaining the adjustment.

Belt Maintenance

Servicing the Engine Belts

Service Interval: After the first 10 hours—Check the condition and tension of all belts.

Every 100 hours—Check the condition and tension of all belts.

Tensioning the Alternator/Fan Belt

1. Open the hood.
2. Check the tension by depressing the alternator/fan belt midway between the alternator and crankshaft pulleys with 30 N·m (22 ft-lb) of force (Figure 71).

Note: The belt should deflect 11 mm (7/16 inch).

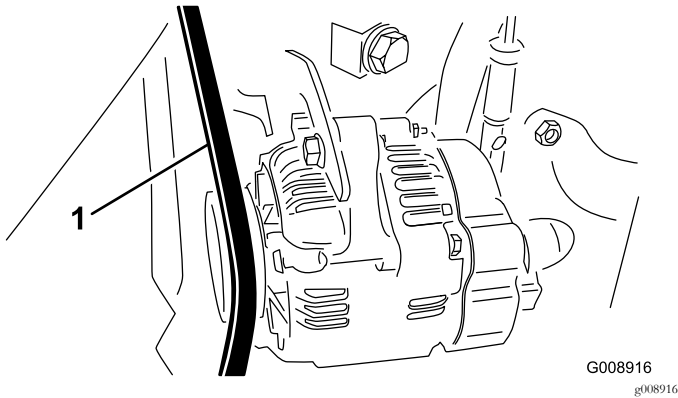

Figure 71

1. Alternator/fan belt

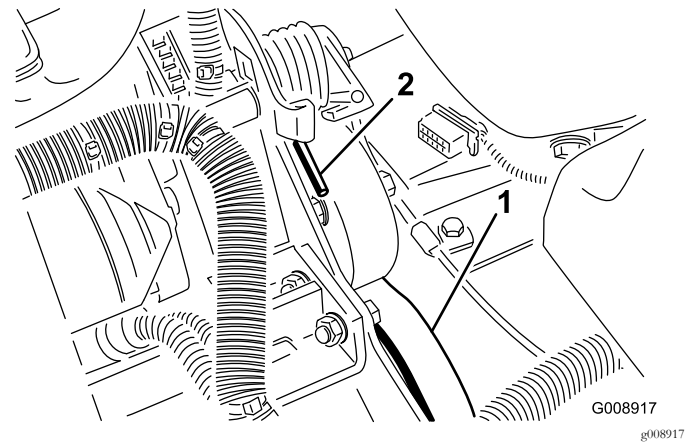

Figure 72

1. Hydrostat drive belt
2. Spring end

3. Replace the belt.
4. Reverse the procedure to tension the spring.

3. If the deflection is incorrect, complete the following procedure to tension the belt:
 - A. Loosen the bolt that secures the brace to the engine and the bolt that secures the alternator to the brace.
 - B. Insert a pry bar between the alternator and the engine and pry out on the alternator.
 - C. When you achieve the proper belt tension, tighten the alternator and brace bolts to secure the adjustment.

Replacing the Hydrostat Drive Belt

1. Insert a nut driver or small piece of tubing onto the end of the belt tensioning spring.

⚠ WARNING

Use caution when de-tensioning the spring, as it is under a heavy load.

2. Push down and forward on the spring end (Figure 72) to unhook it from the bracket and release tension on the spring.

Controls System Maintenance

Adjusting the Throttle

1. Position the throttle lever rearward so that it stops against the control panel slot.
2. Loosen the throttle cable connector on the injection-pump lever arm (Figure 73).

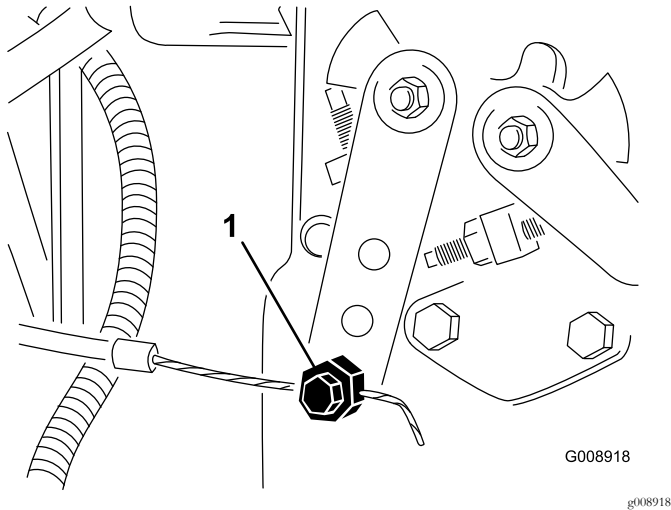

Figure 73

1. Injection-pump lever arm

3. Hold the injection-pump lever arm against the low idle stop and tighten the cable connector.
4. Loosen the screws securing the throttle control to the control panel.
5. Push the throttle control lever all the way forward.
6. Slide the stop plate until it contacts the throttle lever, and tighten the screws that secure the throttle control to the control panel.
7. If the throttle does not stay in position during operation, torque the locknut used to set the friction device on the throttle lever to 5 to 6 N·m (40 to 55 inch-lb).

Note: The maximum force required to operate the throttle lever should be 27 N·m (20 ft-lb).

Hydraulic System Maintenance

Changing the Hydraulic Fluid

Service Interval: Every 400 hours

If the fluid becomes contaminated, contact a Toro distributor to flush the hydraulic system. Contaminated hydraulic fluid looks milky or black when compared to clean fluid.

1. Turn the engine off and raise the hood.
2. Disconnect the hydraulic line (Figure 74) or remove the hydraulic filter (Figure 75) and let the hydraulic fluid flow into a drain pan.

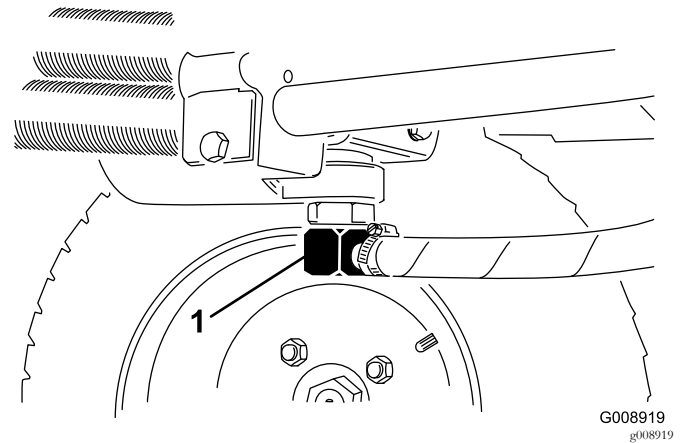

Figure 74

1. Hydraulic line

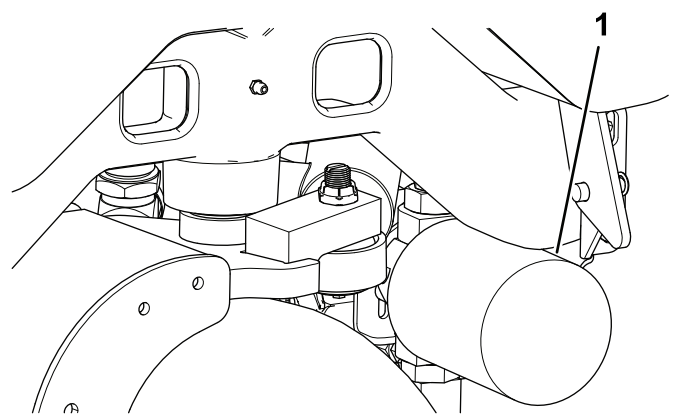

Figure 75

1. Hydraulic filter

3. Install the hydraulic line when hydraulic fluid stops draining.
4. Fill the reservoir (Figure 76) with approximately 13.2 L (3.5 US gallons) of hydraulic fluid; refer to [Checking the Hydraulic System](#) (page 31).

Important: Use only the hydraulic fluids specified. Other fluids could damage the hydraulic system.

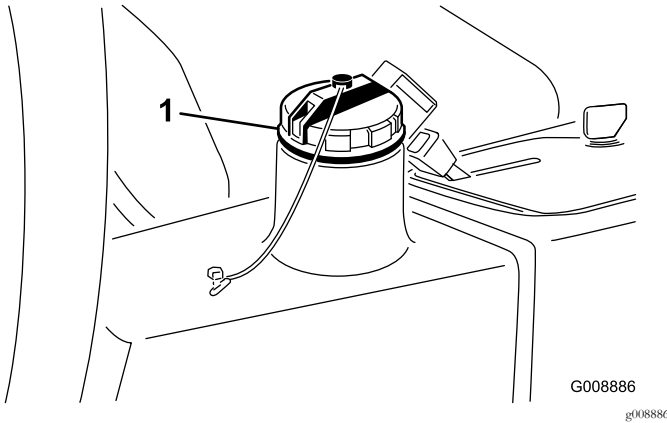

Figure 76

1. Hydraulic fill cap

5. Install the reservoir cap, start the engine, and use all of the hydraulic controls to distribute the hydraulic fluid throughout the system.
6. Check for leaks; then shut off the engine.
7. Check the fluid level and add enough to raise the level to Full mark on the dipstick. **Do not overfill.**

Changing the Hydraulic Filter

Service Interval: After the first 10 hours

Every 200 hours/Yearly (whichever comes first)

Use a genuine Toro replacement filter (Part No. 54-0110).

Important: Using any other filter may void the warranty on some components.

1. Park the machine on a level surface, lower the cutting units, shut off the engine, engage the parking brake, and remove the key from the ignition switch.
2. Pinch off the hose to the filter mounting plate.
3. Clean around the filter mounting area.
4. Place a drain pan under the filter (Figure 75) and remove the filter.
5. Lubricate the new filter gasket and fill the filter with hydraulic fluid.
6. Ensure that the filter mounting area is clean, screw the filter on until the gasket contacts the mounting plate, and then tighten the filter 1/2 turn.
7. Release the hose to the filter mounting plate.
8. Start the engine and let it run for about 2 minutes to purge the air from the system.
9. Shut off the engine and check for leaks.

Checking the Hydraulic Lines and Hoses

Service Interval: Before each use or daily

Check hydraulic lines and hoses for leaks, kinked lines, loose mounting supports, wear, loose fittings, weather deterioration, and chemical deterioration. Make all necessary repairs before operating.

⚠ WARNING

Hydraulic fluid escaping under pressure can penetrate skin and cause injury.

- Ensure that all hydraulic fluid hoses and lines are in good condition and all hydraulic connections and fittings are tight before applying pressure to the hydraulic system.
- Keep your body and hands away from pin hole leaks or nozzles that eject high-pressure hydraulic fluid.
- Use cardboard or paper to find hydraulic leaks.
- Safely relieve all pressure in the hydraulic system before performing any work on the hydraulic system.
- Seek immediate medical attention if fluid is injected into skin.

Miscellaneous Maintenance

Backlapping the Cutting Units

▲ DANGER

Contacting the reels may cause personal injury or death.

- Never place your hands or feet in the reel area while the engine is running.
- While backlapping, the reels may stall and then start again.
- Do not attempt to start reels again with your hand or foot.
- Do not adjust the reels while the engine is running.
- If the reel stalls, shut off the engine before attempting to clear the reel.

1. Park the machine on a clean and level surface, lower the cutting units, shut off the engine, engage the parking brake, and remove the key from the ignition switch.
2. Remove the console cover to expose the controls.
3. Rotate the backlap control to the backlap position (R). Rotate the reel speed control to position 1 (Figure 77).

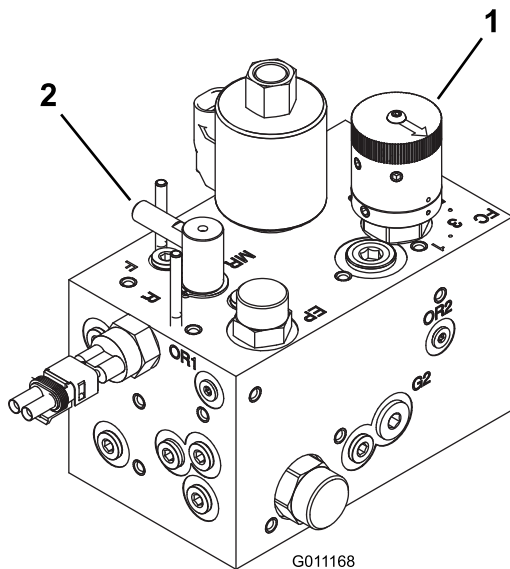

Figure 77

1. Reel speed control
2. Backlap control

Important: Do not rotate the backlap control from the mow position to the backlap position while engine is running. Otherwise, you may damage the reels.

4. Make the initial reel-to-bedknife adjustments appropriate for backlapping on all cutting units. Start the engine and set it to low idle speed.
5. Engage the reels by engaging the PTO switch on the control panel.
6. Apply lapping compound with long-handled brush.
7. To adjust the cutting units while backlapping, disengage the reels and turn the engine off. After you have made the adjustments, repeat steps 4 through 6.
8. After backlapping, shut off the engine, rotate the backlap control to the mow position (F), set the reel speed controls to the desired mowing setting, and wash all the lapping compound off the cutting units.

Note: Additional instructions and procedures on backlapping are available in the Toro Reel Mower Basics (with sharpening guidelines), Form 09168SL.

Note: For a better cutting edge, run a file across the front face of the bedknife after lapping. This removes any burrs or rough edges that may have built up on the cutting edge.

Note: The seat switch is bypassed when the backlap control is in the backlap position. You do not need to be in the seat, but the parking brake must be engaged for the engine to run.

Storage

Preparation for Seasonal Storage

Follow these procedures anytime you will be storing the machine for more than 30 days.

Preparing the Traction Unit

1. Thoroughly clean the traction unit, cutting units, and engine.
2. Check the tire pressure. Inflate all tires to 97 to 110 kPa (14 to 18 psi).
3. Check for loose fasteners and tighten them as necessary.
4. Grease or oil all grease fittings and pivot points. Wipe up any excess lubricant.
5. Lightly sand and use touch-up paint on painted areas that are scratched, chipped, or rusted. Repair any dents in the metal body.
6. Service the battery and cables as follows:
 - A. Remove the battery terminals from the battery posts.
 - B. Remove the battery.
 - C. Slowly charge the battery before storage and every 60 days thereafter for 24 hours to prevent lead sulfation of the battery.

Note: To prevent the battery from freezing, ensure that it is fully charged. The specific gravity of a fully charged battery is 1.265 to 1.299.
 - D. Clean the battery, terminals, and posts with a wire brush and baking soda solution.
 - E. Coat the cable terminals and battery posts with Grafo 112X skin-over grease (Toro Part 505-47) or petroleum jelly to prevent corrosion.
 - F. Either store the battery on the shelf or on the machine in a cool area. Leave the cables disconnected if the battery is stored on the machine.

Preparing the Engine

1. Drain the engine oil from the engine and install the drain plug.
2. Remove and discard the oil filter.
3. Install a new oil filter.
4. Fill the engine with approximately 3.8 L (4 US qt) of SAE 15W-40 motor oil.
5. Start the engine and run it at idle speed for approximately 2 minutes.

6. Shut off the engine.
7. Thoroughly drain all the fuel from the fuel tank, fuel lines, fuel filter, and water-separator assembly.
8. Flush the fuel tank with fresh, clean diesel fuel.
9. Secure all the fuel-system fittings.
10. Thoroughly clean and service the air-cleaner assembly.
11. Seal the air-cleaner inlet and the exhaust outlet with weatherproof tape.
12. Check the antifreeze protection and add antifreeze/coolant as needed for the expected minimum temperature in your area.

European Privacy Notice

The Information Toro Collects

Toro Warranty Company (Toro) respects your privacy. In order to process your warranty claim and contact you in the event of a product recall, we ask you to share certain personal information with us, either directly or through your local Toro company or dealer.

The Toro warranty system is hosted on servers located within the United States where privacy law may not provide the same protection as applies in your country.

BY SHARING YOUR PERSONAL INFORMATION WITH US, YOU ARE CONSENTING TO THE PROCESSING OF YOUR PERSONAL INFORMATION AS DESCRIBED IN THIS PRIVACY NOTICE.

The Way Toro Uses Information

Toro may use your personal information to process warranty claims, to contact you in the event of a product recall and for any other purpose which we tell you about. Toro may share your information with Toro's affiliates, dealers or other business partners in connection with any of these activities. We will not sell your personal information to any other company. We reserve the right to disclose personal information in order to comply with applicable laws and with requests by the appropriate authorities, to operate our systems properly or for our own protection or that of other users.

Retention of your Personal Information

We will keep your personal information as long as we need it for the purposes for which it was originally collected or for other legitimate purposes (such as regulatory compliance), or as required by applicable law.

Toro's Commitment to Security of Your Personal Information

We take reasonable precautions in order to protect the security of your personal information. We also take steps to maintain the accuracy and current status of personal information.

Access and Correction of your Personal Information

If you would like to review or correct your personal information, please contact us by email at legal@toro.com.

Australian Consumer Law

Australian customers will find details relating to the Australian Consumer Law either inside the box or at your local Toro Dealer.



The Toro Warranty

A Two-Year Limited Warranty

Conditions and Products Covered

The Toro Company and its affiliate, Toro Warranty Company, pursuant to an agreement between them, jointly warrant your Toro Commercial product ("Product") to be free from defects in materials or workmanship for two years or 1500 operational hours*, whichever occurs first. This warranty is applicable to all products with the exception of Aerators (refer to separate warranty statements for these products). Where a warrantable condition exists, we will repair the Product at no cost to you including diagnostics, labor, parts, and transportation. This warranty begins on the date the Product is delivered to the original retail purchaser.

* Product equipped with an hour meter.

Instructions for Obtaining Warranty Service

You are responsible for notifying the Commercial Products Distributor or Authorized Commercial Products Dealer from whom you purchased the Product as soon as you believe a warrantable condition exists. If you need help locating a Commercial Products Distributor or Authorized Dealer, or if you have questions regarding your warranty rights or responsibilities, you may contact us at:

Toro Commercial Products Service Department
Toro Warranty Company
8111 Lyndale Avenue South
Bloomington, MN 55420-1196
952-888-8801 or 800-952-2740
E-mail: commercial.warranty@toro.com

Owner Responsibilities

As the Product owner, you are responsible for required maintenance and adjustments stated in your *Operator's Manual*. Failure to perform required maintenance and adjustments can be grounds for disallowing a warranty claim.

Items and Conditions Not Covered

Not all product failures or malfunctions that occur during the warranty period are defects in materials or workmanship. This warranty does not cover the following:

- Product failures which result from the use of non-Toro replacement parts, or from installation and use of add-on, or modified non-Toro branded accessories and products. A separate warranty may be provided by the manufacturer of these items.
- Product failures which result from failure to perform recommended maintenance and/or adjustments. Failure to properly maintain your Toro product per the Recommended Maintenance listed in the *Operator's Manual* can result in claims for warranty being denied.
- Product failures which result from operating the Product in an abusive, negligent, or reckless manner.
- Parts subject to consumption through use unless found to be defective. Examples of parts which are consumed, or used up, during normal Product operation include, but are not limited to, brake pads and linings, clutch linings, blades, reels, rollers and bearings (sealed or greasable), bed knives, spark plugs, castor wheels and bearings, tires, filters, belts, and certain sprayer components such as diaphragms, nozzles, and check valves, etc.
- Failures caused by outside influence. Conditions considered to be outside influence include, but are not limited to, weather, storage practices, contamination, use of unapproved fuels, coolants, lubricants, additives, fertilizers, water, or chemicals, etc.
- Failure or performance issues due to the use of fuels (e.g. gasoline, diesel, or biodiesel) that do not conform to their respective industry standards.

Countries Other than the United States or Canada

Customers who have purchased Toro products exported from the United States or Canada should contact their Toro Distributor (Dealer) to obtain guarantee policies for your country, province, or state. If for any reason you are dissatisfied with your Distributor's service or have difficulty obtaining guarantee information, contact the Toro importer.

- Normal noise, vibration, wear and tear, and deterioration.
- Normal "wear and tear" includes, but is not limited to, damage to seats due to wear or abrasion, worn painted surfaces, scratched decals or windows, etc.

Parts

Parts scheduled for replacement as required maintenance are warranted for the period of time up to the scheduled replacement time for that part. Parts replaced under this warranty are covered for the duration of the original product warranty and become the property of Toro. Toro will make the final decision whether to repair any existing part or assembly or replace it. Toro may use remanufactured parts for warranty repairs.

Deep Cycle and Lithium-Ion Battery Warranty:

Deep cycle and Lithium-Ion batteries have a specified total number of kilowatt-hours they can deliver during their lifetime. Operating, recharging, and maintenance techniques can extend or reduce total battery life. As the batteries in this product are consumed, the amount of useful work between charging intervals will slowly decrease until the battery is completely worn out. Replacement of worn out batteries, due to normal consumption, is the responsibility of the product owner. Battery replacement may be required during the normal product warranty period at owner's expense. Note: (Lithium-Ion battery only): A Lithium-Ion battery has a part only prorated warranty beginning year 3 through year 5 based on the time in service and kilowatt hours used. Refer to the *Operator's Manual* for additional information.

Maintenance is at Owner's Expense

Engine tune-up, lubrication, cleaning and polishing, replacement of filters, coolant, and completing recommended maintenance are some of the normal services Toro products require that are at the owner's expense.

General Conditions

Repair by an Authorized Toro Distributor or Dealer is your sole remedy under this warranty.

Neither The Toro Company nor Toro Warranty Company is liable for indirect, incidental or consequential damages in connection with the use of the Toro Products covered by this warranty, including any cost or expense of providing substitute equipment or service during reasonable periods of malfunction or non-use pending completion of repairs under this warranty. Except for the Emissions warranty referenced below, if applicable, there is no other express warranty. All implied warranties of merchantability and fitness for use are limited to the duration of this express warranty.

Some states do not allow exclusions of incidental or consequential damages, or limitations on how long an implied warranty lasts, so the above exclusions and limitations may not apply to you. This warranty gives you specific legal rights, and you may also have other rights which vary from state to state.

Note regarding engine warranty:

The Emissions Control System on your Product may be covered by a separate warranty meeting requirements established by the U.S. Environmental Protection Agency (EPA) and/or the California Air Resources Board (CARB). The hour limitations set forth above do not apply to the Emissions Control System Warranty. Refer to the Engine Emission Control Warranty Statement supplied with your product or contained in the engine manufacturer's documentation for details.