



Count on it.

Parts Catalog

TimeCutter® SS 4225

Riding Mower

Model No. 74721—Serial No. 40000000 and Up



Ordering Replacement Parts

To order replacement parts, please supply the part number, the quantity, and the description of each part desired.

Understanding Reference Numbers

Each identified part in an illustration has a reference number. The reference number for a part also appears in the parts list, along with other information about the part.

This catalog uses two special reference number formats, one to indicate parts in a service assembly and another to indicate the quantity of a given part in an illustration.

Service Assembly Reference Numbers

Parts in service assemblies have reference numbers in the form a:b. The a represents the reference number of the entire service assembly and the b represents a sequential number unique to each part within the service assembly.

For example, a wheel assembly might be identified by reference number 6, the tire by 6:1, the valve by 6:2, and the wheel by 6:3. When you order the assembly identified by reference number 6, you receive all parts identified by reference numbers 6:1, 6:2, and 6:3. However, you may also order any part individually. Reference numbers of this type appear in illustration and in parts lists.

Reference Numbers Indicating Quantity

In an illustration, if a reference number indicates more than one part, the reference number has the form nX y. The n represents the quantity of the part, the X is the multiplication symbol, and the y represents the reference number.

For example, in an illustration, the reference number 2X 37 means that two of the parts identified by reference number 37 are indicated.

Contents

Frame and Front Axle Assembly	4
Deck Lift Assembly.....	6
Fork and Caster Wheel Assembly	8
Traction Drive Assembly	10
Left Hand Hydro Transaxle Assembly No. 119-3330	12
Right Hand Hydro Transaxle Assembly No. 119-3331	14
Brake Assembly	16
Tire Assembly No. 131-3671	18
Seat Assembly	20
Motion Control Assembly	22
Engine and Muffler Assembly.....	24
Body Styling and Fuel Assembly	26
Battery and Electrical Assembly.....	28
42 Inch Deck Assembly.....	30
42 Inch Deck Assembly No. 131-3604	32
Model Specific Decal Assembly.....	34
Speed Control, HOC and Service Decal Assembly.....	36
Clutch Assembly.....	38
Attachments and Accessories	40

Frame and Front Axle Assembly

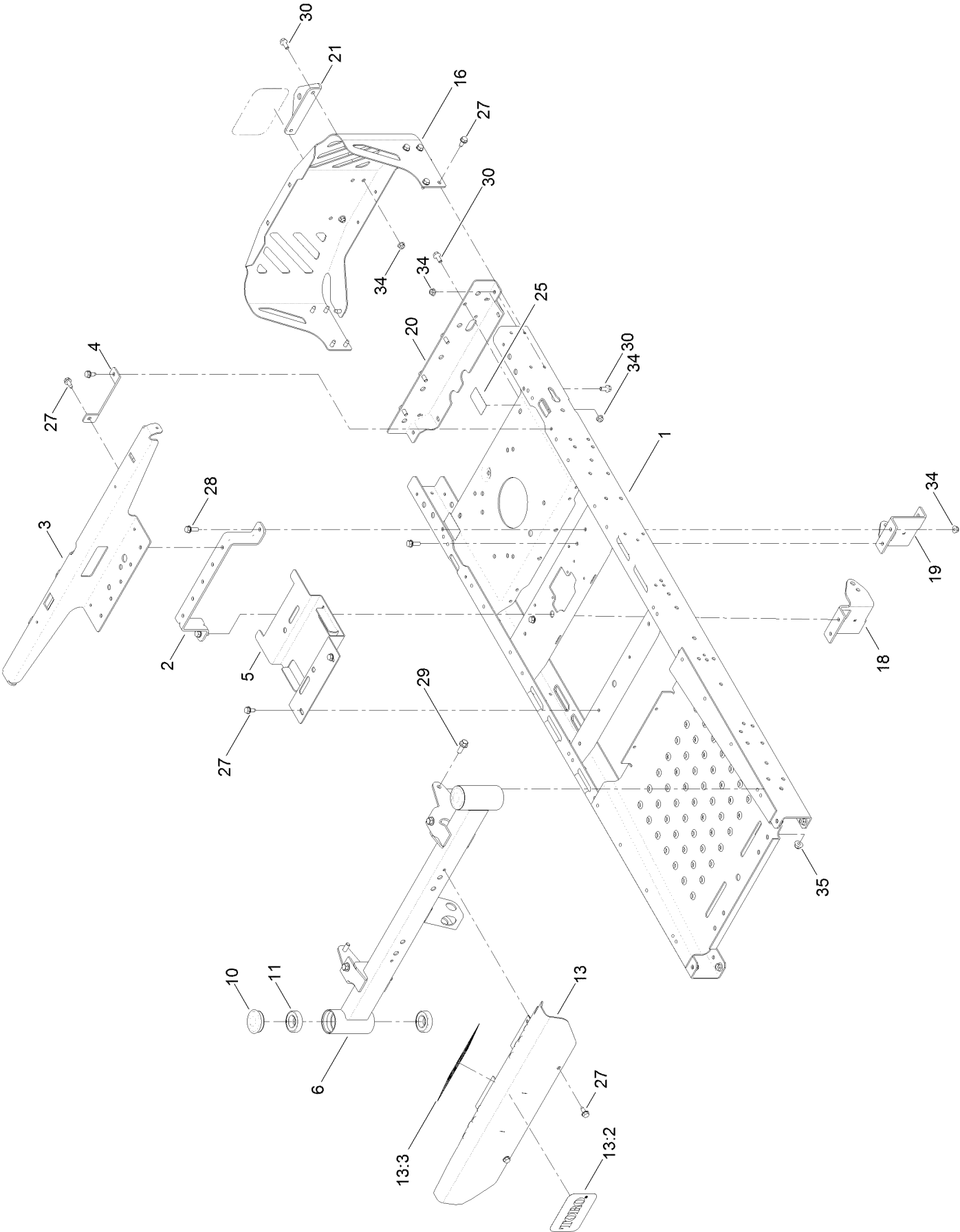

Frame and Front Axle Assembly (continued)

<i>Ref.</i>	<i>Part Number</i>	<i>Qty.</i>	<i>Description</i>	<i>Ref.</i>	<i>Part Number</i>	<i>Qty.</i>	<i>Description</i>
1	127-3444-01	1	Frame ASM	18	131-0901-01	1	Mount-Hydro, Front (Right)
2	119-3435-03	1	Brace-Seat, Rear (Narrow)	19	131-0902-01	1	Mount-Hydro, Front (Left)
3	131-1040-03	1	Support-Pod	20	130-6950-01	1	Crossmember-Rear, Narrow
4	119-3431-03	2	Support-Tank, Rear	21	117-1232-03	1	Bracket-Hitch
5	131-0914-03	1	Bracket-Battery	25	121-2989	2	Decal-Bypass
6	125-1742-01	1	Axle-Front, Narrow	27	32144-70	18	Screw-HWHTF
10	116-4348	2	Cap-Grease	28	3234-29	4	Screw-HHF
11	109-3678	4	Bearing-Ball	29	3234-42	6	Screw-HHF
13	132-0890	1	Footrest ASM	30	3234-47	8	Screw-HHF
13:2	105-8278	1	Decal	34	104-8300	12	Nut-Flange, NI
13:3	132-0869	1	Decal-Danger	35	104-8301	6	Nut-Flange, NI
16	127-3353-03	1	Guard-Engine, Narrow				

Deck Lift Assembly

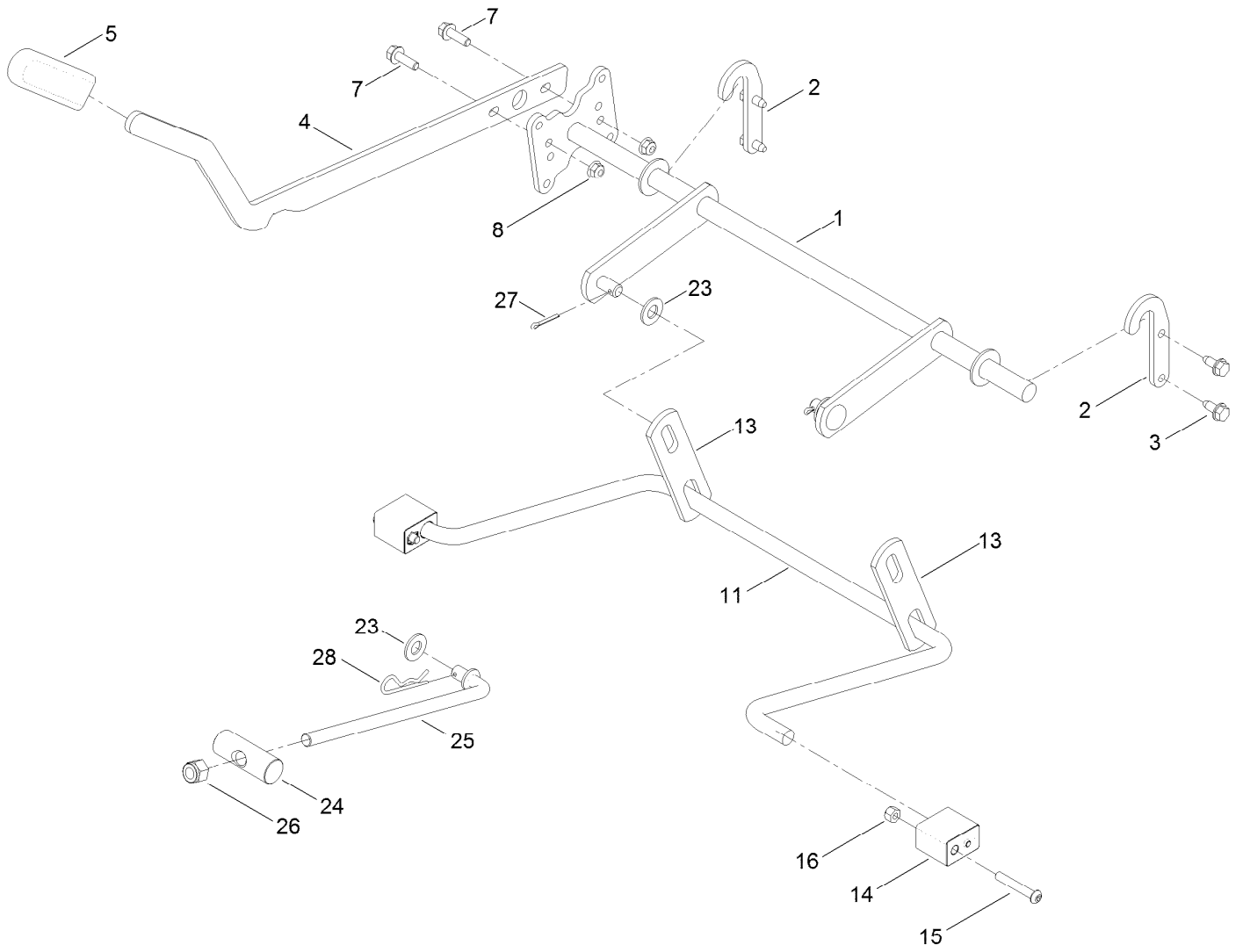

Deck Lift Assembly (continued)

<i>Ref.</i>	<i>Part Number</i>	<i>Qty.</i>	<i>Description</i>	<i>Ref.</i>	<i>Part Number</i>	<i>Qty.</i>	<i>Description</i>
1	132-6872-03	1	Lift-Deck, Narrow	14	108-7845	2	Block-Pivot
2	119-8875	2	Bracket-Lift	15	120-5499	2	Screw-HSBH
3	32144-70	4	Screw-HWHTF	16	3296-29	2	Nut-Lock, NI
4	119-3427-03	1	Lever-Lift	23	3256-26	3	Washer-Flat
5	1-633268	1	Grip-Lever	24	119-8810	1	Pin-Pivot
7	3234-29	2	Screw-HHF	25	133-4319	1	Rod-Mount, Deck
8	104-8300	2	Nut-Flange, NI	26	3296-19	1	Nut-Hex
11	108-7839	1	Arm-Lift, Rear	27	3272-11	2	Pin-Cotter
13	108-7840	2	Link-Lift	28	1-806005	1	Pin-Cotter

Fork and Caster Wheel Assembly

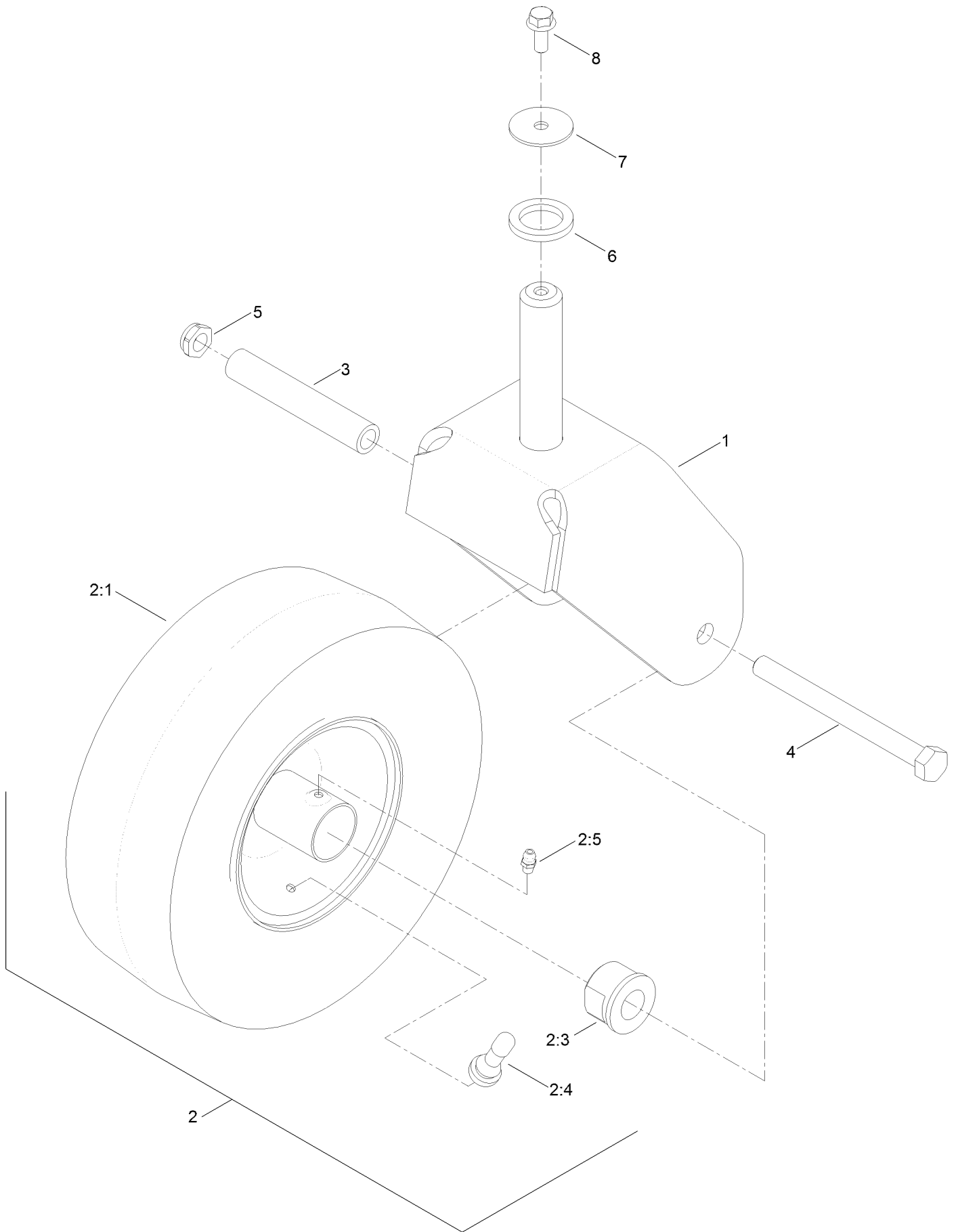

Fork and Caster Wheel Assembly (continued)

<i>Ref.</i>	<i>Part Number</i>	<i>Qty.</i>	<i>Description</i>	<i>Ref.</i>	<i>Part Number</i>	<i>Qty.</i>	<i>Description</i>
1	120-2266-01	2	Fork-Caster	3	104-3667	2	Spanner-Wheel
2	130-0736	2	Caster Wheel ASM	4	325-22	2	Screw-HH
2:1	130-0735	1	Tire	5	3296-45	2	Nut-Lock, NI
2:3	114-1640	2	Bushing-Flange	6	117-7394	2	Washer-Thrust
2:4	232-27	1	Stem-Valve	7	3256-68	2	Washer-Flat
2:5	302-5	1	Fitting-Grease	8	3234-47	2	Screw-HHF
2:6	105-0844	1	Tube-Inner ■●				

● Not illustrated

■ Optional Equipment

Traction Drive Assembly

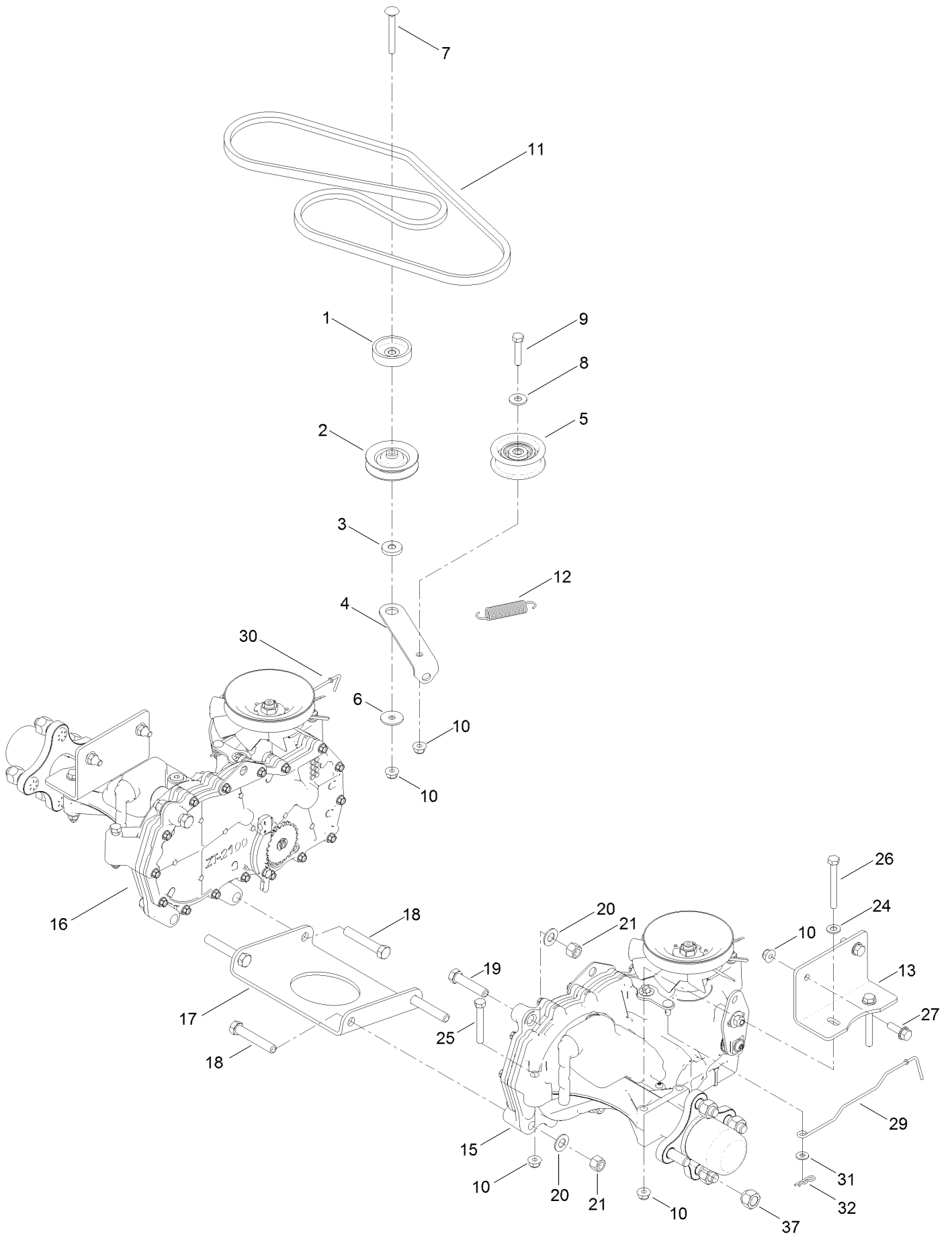

Traction Drive Assembly (continued)

<i>Ref.</i>	<i>Part Number</i>	<i>Qty.</i>	<i>Description</i>	<i>Ref.</i>	<i>Part Number</i>	<i>Qty.</i>	<i>Description</i>
1	119-3353	1	Spacer	17	119-3339-03	1	Plate-Cross, Hydro
2	119-8822	1	Pulley-Idler	18	324-10	4	Screw-HH
3	119-3327	1	Spacer-Arm, Idler	19	324-8	2	Screw-HH
4	119-3326	1	Arm-Idler	20	3256-25	6	Washer-Flat
5	106-2176	1	Pulley-Idler	21	3296-48	6	Nut-Lock, NI
6	5-4460	1	Washer-Pivot	24	3256-23	6	Washer-Flat
7	3230-8	1	Screw-CARR	25	322-11	4	Screw-HH
8	3256-3	1	Washer-Flat	26	322-13	4	Screw-HH
9	322-7	1	Screw-HH	27	3234-29	4	Screw-HHF
10	104-8300	14	Nut-Flange, NI	29	131-0900	1	Rod-Bypass, LH
11	130-6975	1	V-Belt	30	130-7049	1	Rod-Bypass, RH
12	104-6415	1	Spring-Return, Pedal	31	119-8952	2	Washer
13	117-7264-03	2	Mount-Hydro	32	3290-307	2	Pin-Cotter
15	119-3330	1	LH Hydro Transaxle ASM	35	614249	2	Tie-Cable ●
16	119-3331	1	RH Hydro Transaxle ASM	37	242-50	8	Nut-Lug

● Not illustrated

Left Hand Hydro Transaxle Assembly No. 119-3330

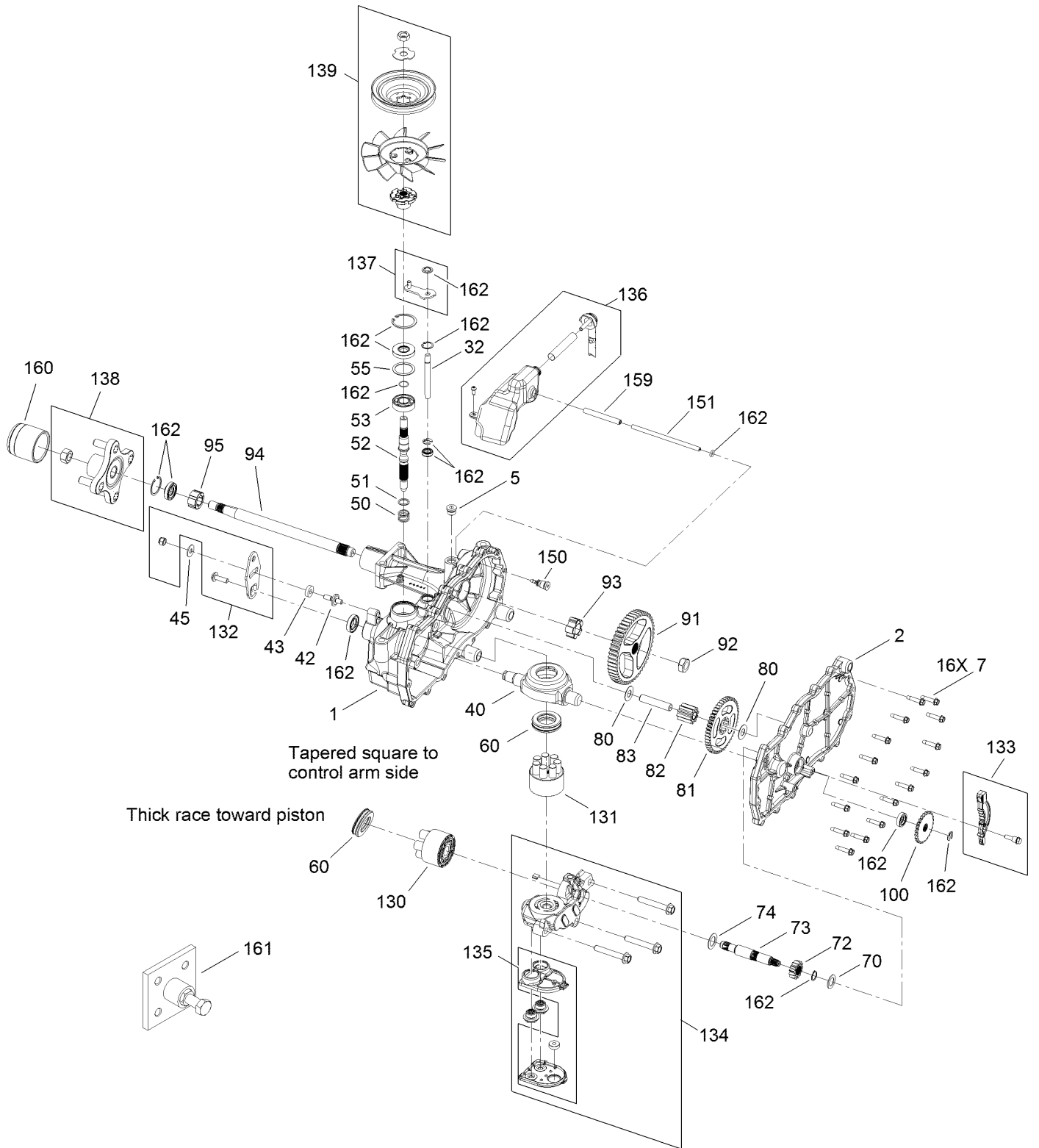

Left Hand Hydro Transaxle Assembly No. 119-3330 (continued)

<i>Ref.</i>	<i>Part Number</i>	<i>Qty.</i>	<i>Description</i>	<i>Ref.</i>	<i>Part Number</i>	<i>Qty.</i>	<i>Description</i>
1	120-5532	1	Main Housing ASM	83	104-5329	1	Pin-Jackshaft
2	120-5534	1	Housing Side Kit	91	120-5539	1	Gear-Bull
5	104-2189	1	Plug-Thread, Straight	92	104-2142	1	Nut-HJ
7	117-5359	16	Screw-HHF	93	115-8314	1	Bushing-Inboard
13	104-2147	1	Sealant ●	94	120-5540	1	Shaft-Axle
32	106-8678	2	Rod-Bypass	95	120-5541	1	Bearing-Sleeve
40	104-5304	1	Swashplate-Trunnion	100	106-8694	1	Disc-Brake, Cog
42	104-2116	1	Stud	130	103-2666	1	Cylinder Block Kit
43	112-9853	1	Puck-Friction	131	110-8561	1	Pump Block ASM
45	114-8491	1	Washer	132	117-5362	1	Arm Control Kit
50	120-5537	1	Spring-Compression	133	106-8688	1	Brake Arm Kit
51	120-5538	1	Washer	134	112-9861	1	Center Section Filter Kit
52	104-5306	1	Shaft-Input	135	114-1634	1	Filter Kit
53	104-5311	1	Bearing-Ball	136	121-5730	1	RH Expansion Tank Kit
55	104-5308	1	Spacer	137	120-5549	1	Bypass Kit
60	94-6922	1	Bearing-Thrust	138	121-5731	1	Hub Kit
70	104-5339	1	Washer-Flat	139	121-5729	1	Fan Pulley Kit
72	104-5316	1	Gear-Pinion, 13T	150	104-5349	1	Fitting-SAE
73	106-8683	1	Shaft-Motor	151	115-8302	1	Hose
74	104-5360	1	Washer	159	121-5728	1	Case-Tube
80	119-5541	2	Washer	160	125-0041	1	Cap-Axle
81	104-5317	1	Gear-10T/48T	161	114-8467	1	Hub-Puller, 4 Bolt
82	104-5318	1	Gear-Jackshaft, 10T	162	120-7103	1	Seal And Ring Kit

● Not illustrated

Right Hand Hydro Transaxle Assembly No. 119-3331

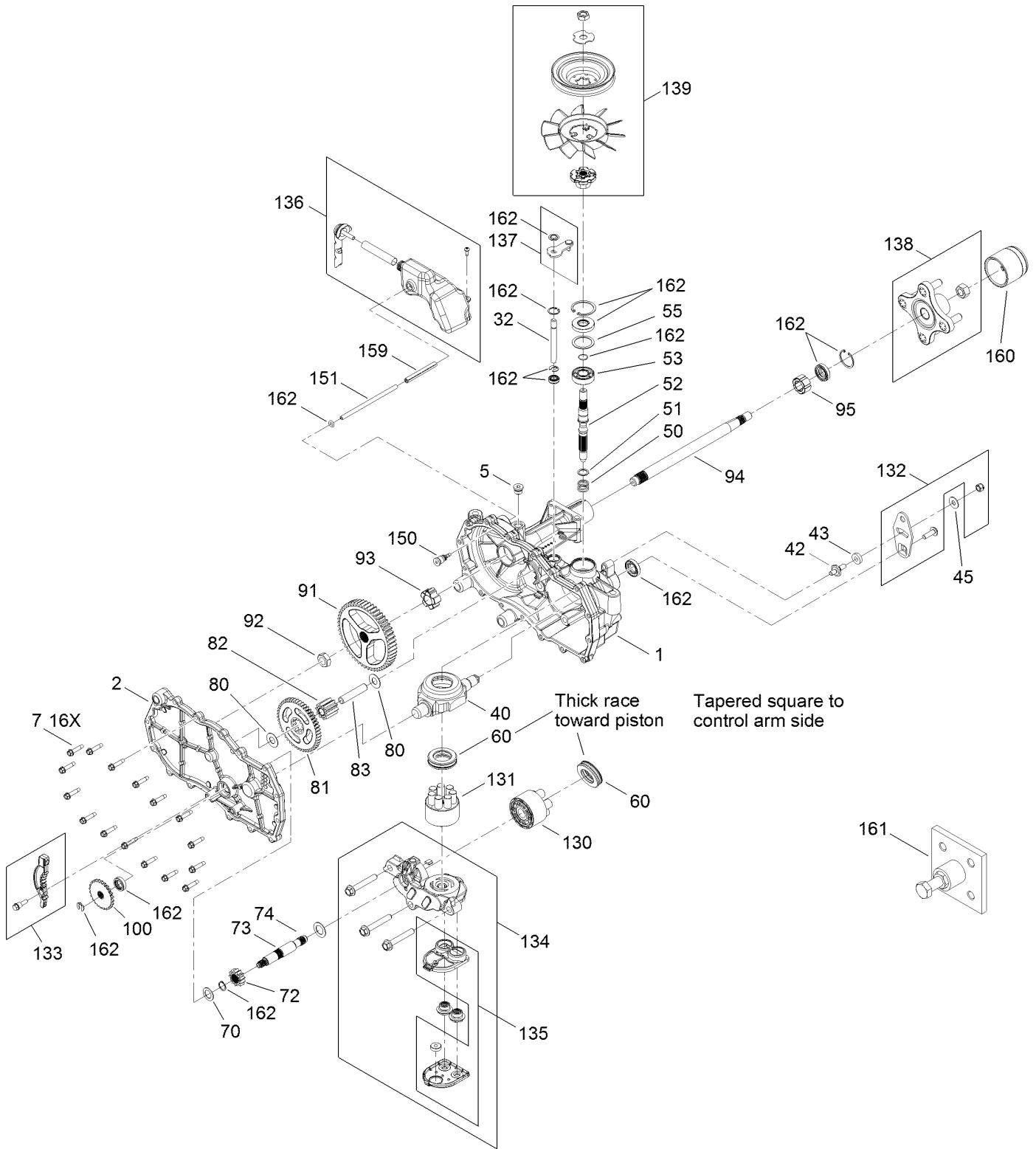

Right Hand Hydro Transaxle Assembly No. 119-3331 (continued)

<i>Ref.</i>	<i>Part Number</i>	<i>Qty.</i>	<i>Description</i>	<i>Ref.</i>	<i>Part Number</i>	<i>Qty.</i>	<i>Description</i>
1	120-5531	1	Main Housing ASM	83	104-5329	1	Pin-Jackshaft
2	120-5533	1	Housing Side Kit	91	120-5539	1	Gear-Bull
5	104-2189	1	Plug-Thread, Straight	92	104-2142	1	Nut-HJ
7	117-5359	16	Screw-HHF	93	115-8314	1	Bushing-Inboard
13	104-2147	1	Sealant ●	94	120-5540	1	Shaft-Axle
32	106-8678	2	Rod-Bypass	95	120-5541	1	Bearing-Sleeve
40	104-5304	1	Swashplate-Trunnion	100	106-8694	1	Disc-Brake, Cog
42	104-2116	1	Stud	130	103-2666	1	Cylinder Block Kit
43	112-9853	1	Puck-Friction	131	110-8561	1	Pump Block ASM
45	114-8491	1	Washer	132	117-5362	1	Arm Control Kit
50	120-5537	1	Spring-Compression	133	106-8688	1	Brake Arm Kit
51	120-5538	1	Washer	134	112-9862	1	Center Section Filter Kit
52	104-5306	1	Shaft-Input	135	114-1634	1	Filter Kit
53	104-5311	1	Bearing-Ball	136	121-5735	1	LH Expansion Tank Kit
55	104-5308	1	Spacer	137	107-2489	1	Bypass Arm Kit
60	94-6922	1	Bearing-Thrust	138	121-5731	1	Hub Kit
70	104-5339	1	Washer-Flat	139	121-5729	1	Fan Pulley Kit
72	104-5316	1	Gear-Pinion, 13T	150	104-5349	1	Fitting-SAE
73	106-8683	1	Shaft-Motor	151	115-8302	1	Hose
74	104-5360	1	Washer	159	121-5728	1	Case-Tube
80	119-5541	2	Washer	160	125-0041	1	Cap-Axle
81	104-5317	1	Gear-10T/48T	161	114-8467	1	Hub-Puller, 4 Bolt
82	104-5318	1	Gear-Jackshaft, 10T	162	120-7103	1	Seal And Ring Kit

● Not illustrated

Brake Assembly

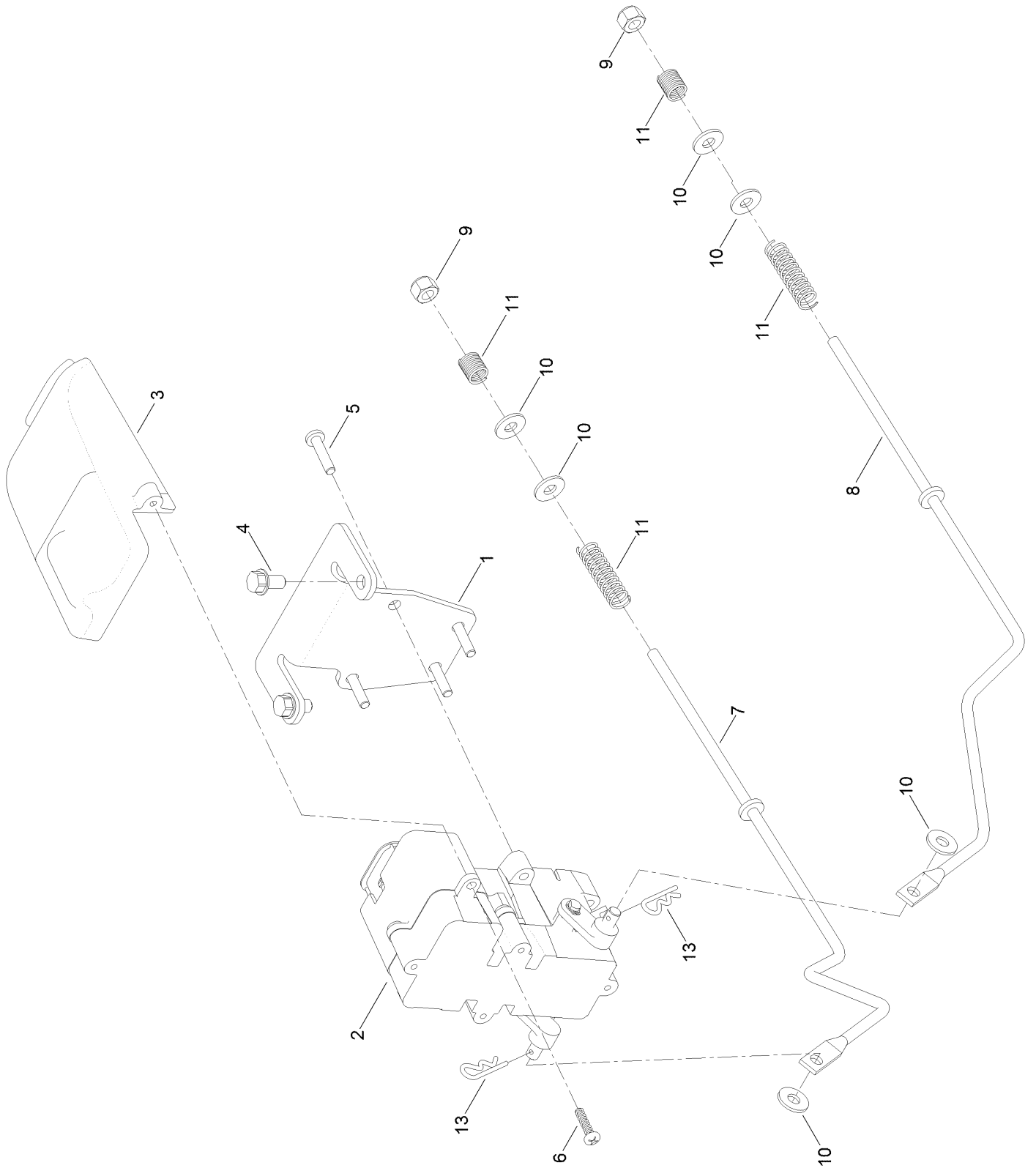

Brake Assembly (continued)

<i>Ref.</i>	<i>Part Number</i>	<i>Qty.</i>	<i>Description</i>	<i>Ref.</i>	<i>Part Number</i>	<i>Qty.</i>	<i>Description</i>
1	130-0790-03	1	Bracket-Mount, Brake	7	121-2974	1	Rod-Brake, RH
2	132-0935	1	Brake Box ASM	8	121-2975	1	Rod-Brake, LH
3	132-6949	1	Cover-Connector	9	3296-42	2	Nut-Lock, NI
4	32144-4	2	Screw-HWH	10	119-8952	6	Washer
5	32144-36	4	Screw-PPH	11	117-1169	4	Spring-Compression
6	94-4496	2	Screw-PPH	13	3290-307	2	Pin-Cotter

Tire Assembly No. 131-3671

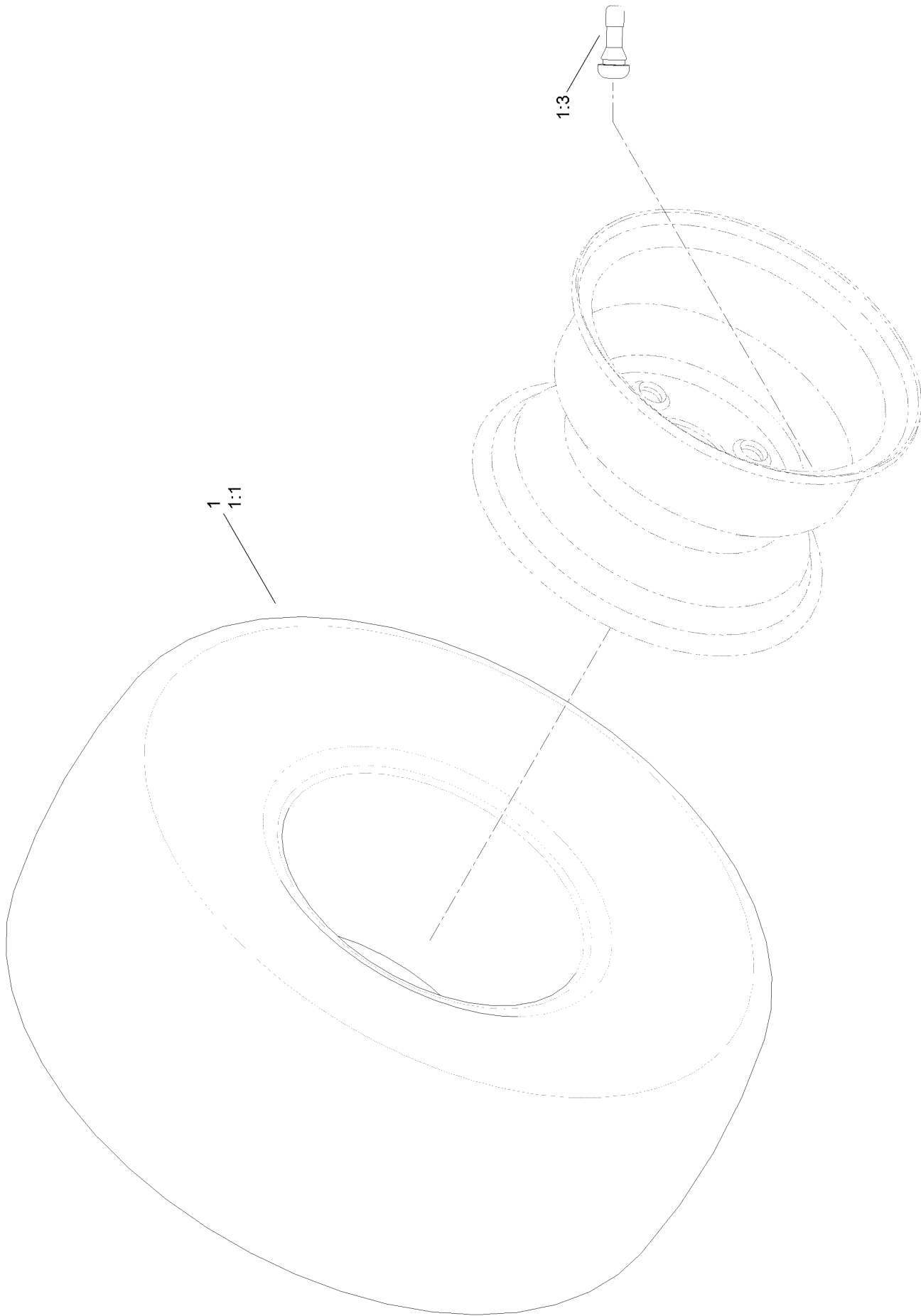

Tire Assembly No. 131-3671 (continued)

<i>Ref.</i>	<i>Part Number</i>	<i>Qty.</i>	<i>Description</i>	<i>Ref.</i>	<i>Part Number</i>	<i>Qty.</i>	<i>Description</i>
1	131-3671	2	2 Ply Wheel And Tire ASM	1:3	232-27	1	Stem-Valve
1:1	131-3678	1	Tire-2 Ply	1:99	107-2491	1	Tube-Tire ●

● Not illustrated

Seat Assembly

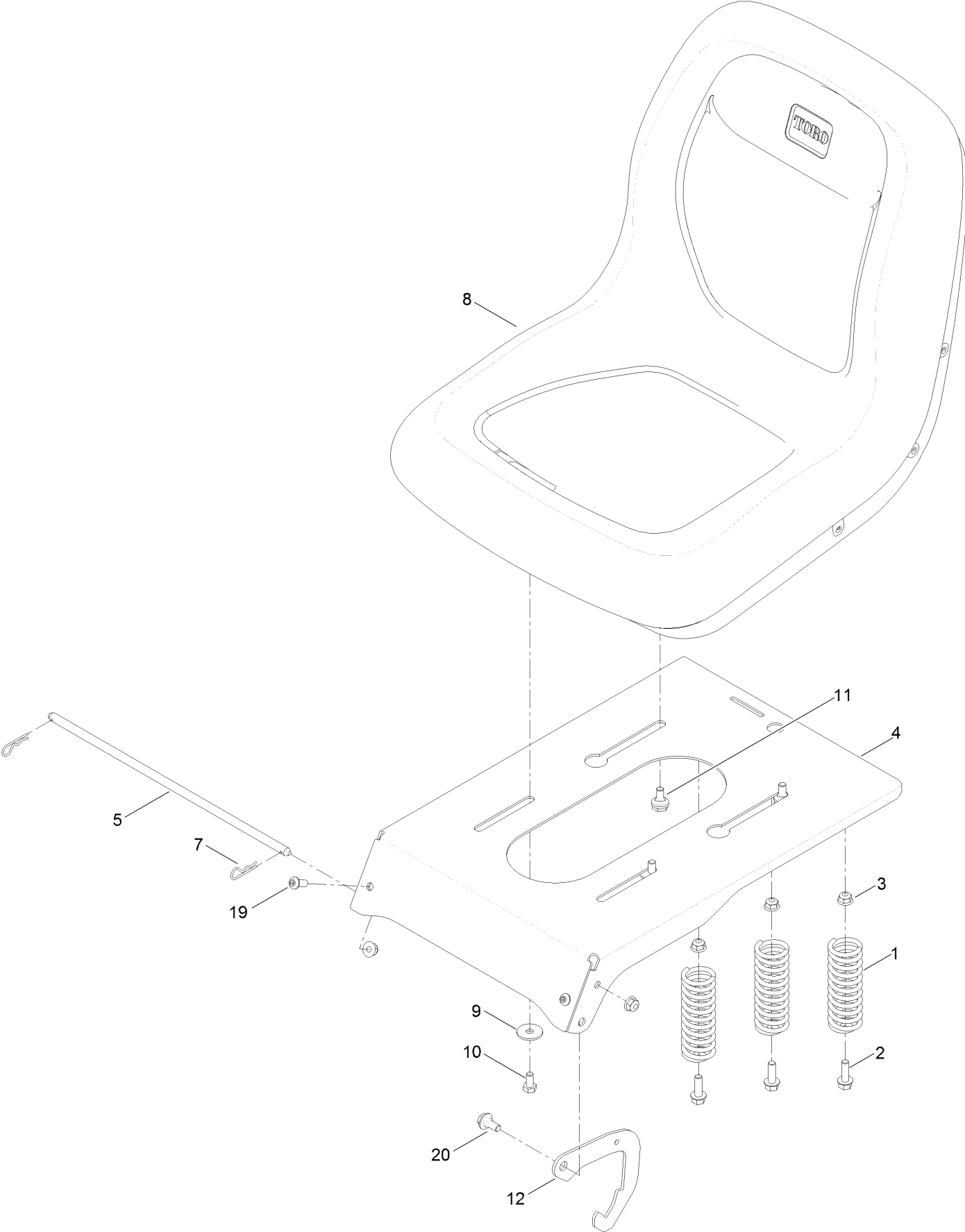

Seat Assembly (continued)

<i>Ref.</i>	<i>Part Number</i>	<i>Qty.</i>	<i>Description</i>	<i>Ref.</i>	<i>Part Number</i>	<i>Qty.</i>	<i>Description</i>
1	92-7054	3	Spring-Compression	9	5-4460	2	Washer-Pivot
2	3234-29	3	Screw-HHF	10	322-2	2	Screw-HH
3	104-8300	5	Nut-Flange, NI	11	37-8771	2	Bolt-Shoulder
4	131-4037-01	1	Pan-Seat	12	132-9353	1	Latch-Seat
5	119-3433	1	Rod-Pivot, Narrow	19	3274-55	2	Screw-HSBH
7	3290-250	2	Pin-Cotter	20	19-1470	1	Screw-Shoulder
8	119-8829	1	Seat-18 Inch				

Motion Control Assembly

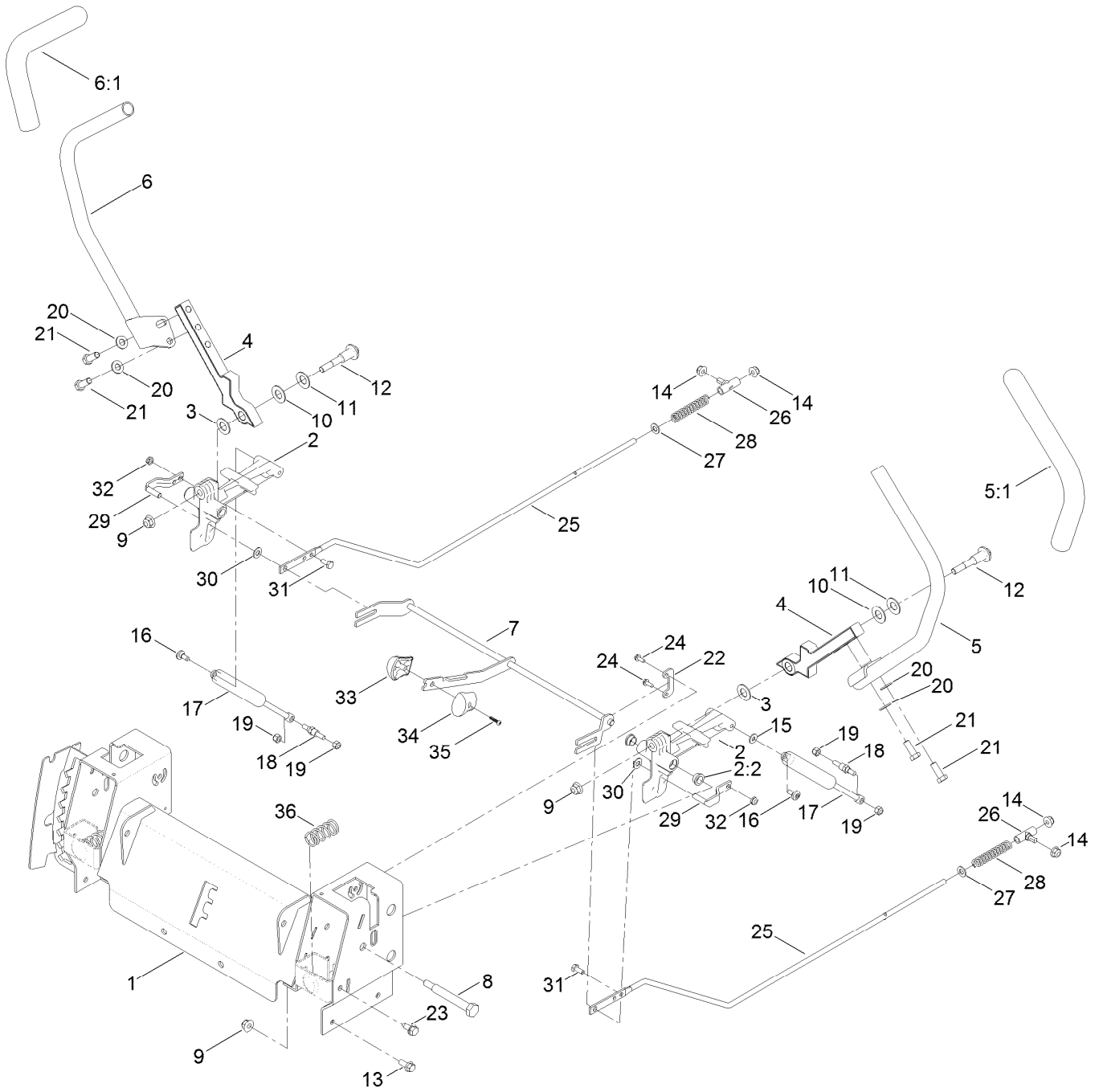

Motion Control Assembly (continued)

<i>Ref.</i>	<i>Part Number</i>	<i>Qty.</i>	<i>Description</i>	<i>Ref.</i>	<i>Part Number</i>	<i>Qty.</i>	<i>Description</i>
1	136-4156-03	1	Control Box ASM	18	110-6810	2	Stud-Damper
2	119-3470	2	Actuator Arm ASM	19	3296-42	4	Nut-Lock, NI
2:2	256-156	2	Bushing-Flange	20	3256-24	4	Washer-Flat
3	120-2273	2	Washer-Nylon	21	323-6	4	Screw-HH
4	115-5098-05	2	Lever-Control	22	117-5385	2	Retainer
5	121-0730	1	Handle-Control, LH	23	32144-70	4	Screw-HWHTF
5:1	121-0726	1	Grip	24	32144-1	4	Screw-Taptite
6	121-0731	1	Handle-Control, RH	25	117-5388	2	Rod-Hydro
6:1	121-0726	1	Grip	26	119-8842	2	Mount-Rod, Hydro
7	131-1094	1	Speed Control ASM	27	3256-23	2	Washer-Flat
8	115-5099	2	Bolt-Pivot	28	1-603807	2	Spring-Return, Neutral
9	104-8301	4	Nut-Flange, NI	29	119-3303	2	Pin-Rod, Hydro
10	117-1240	2	Washer	30	93-6079	2	Spacer-Nylon
11	119-8925	2	Washer-Belleville	31	321-3	2	Screw-HH
12	117-1198	2	Bolt-Pivot	32	3296-56	2	Nut-Lock, NI
13	3234-47	6	Screw-HHF	33	119-8935	1	Knob-RH
14	104-8300	10	Nut-Flange, NI	34	119-8936	1	Knob-LH
15	119-8952	2	Washer	35	94-4496	1	Screw-PPH
16	120-7950	2	Screw-Shoulder	36	119-8876	2	Spring-Return
17	131-4132	2	Damper				

Engine and Muffler Assembly

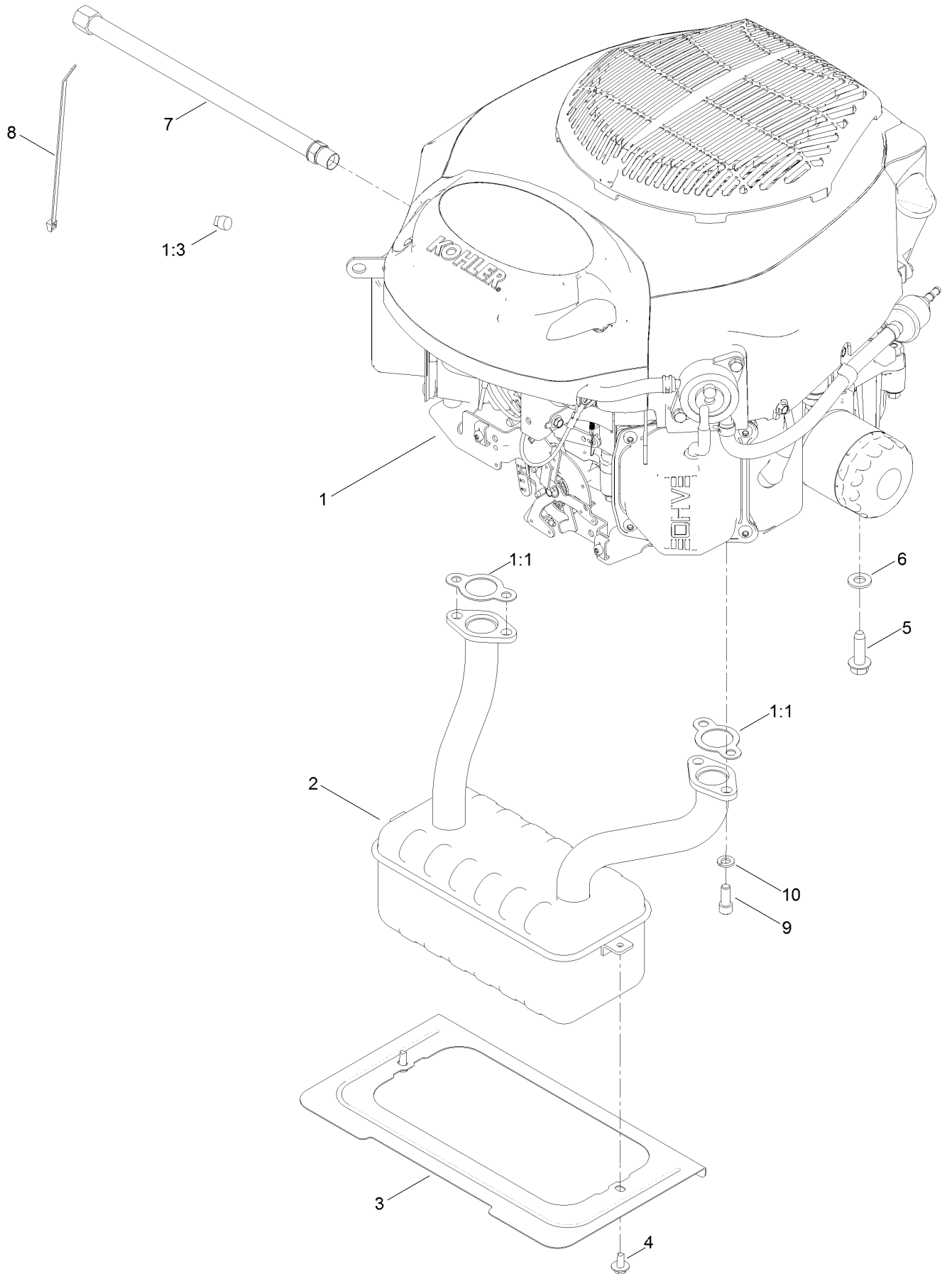

Engine and Muffler Assembly (continued)

<i>Ref.</i>	<i>Part Number</i>	<i>Qty.</i>	<i>Description</i>	<i>Ref.</i>	<i>Part Number</i>	<i>Qty.</i>	<i>Description</i>
1		1	Engine-Kohler 22HP 7000 Series Autochoke ●■	5	32144-109	4	Screw-Taptite
1:1	110-6697	2	Gasket-Exhaust	6	3256-24	3	Washer-Flat
1:3	281-2	1	Plug-Pipe, SQH	7	117-1261	1	Hose-Drain, Oil
2	130-0676	1	Muffler	8	614249	1	Tie-Cable
3	131-1071-03	1	Shield-Heat	9	3274-10	4	Screw-HSH
4	46-8560	2	Screw-HHFTF	10	3253-4	4	Washer-Lock

● Not serviced separately

■ Obtain parts from www.kohlerplus.com

Body Styling and Fuel Assembly

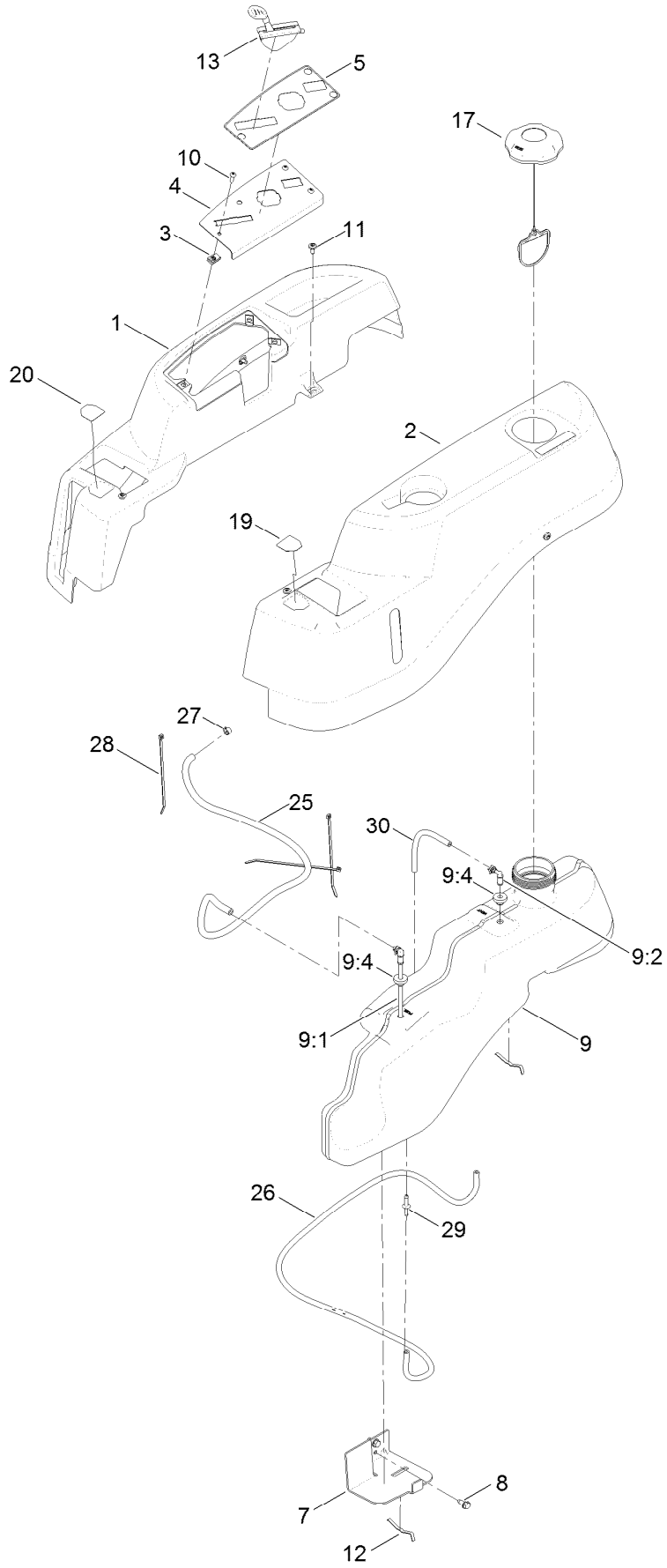

Body Styling and Fuel Assembly (continued)

<i>Ref.</i>	<i>Part Number</i>	<i>Qty.</i>	<i>Description</i>	<i>Ref.</i>	<i>Part Number</i>	<i>Qty.</i>	<i>Description</i>
1	119-3335	1	Pod-RH	11	120-7950	6	Screw-Shoulder
2	119-3334	1	Pod-LH	12	609830	2	Spring
3	107069	3	Clip	13	121-5674	1	Cable-Throttle (45.0 In)
4	119-3378-03	1	Plate-Control	17	120-5461	1	Cap-Fuel, Ratcheting
5	131-4161	1	Decal-Panel, Control	19	119-8814	1	Decal-Control Lever, LH
7	119-3476-03	1	Support-Tank, Front	20	119-8815	1	Decal-Control Lever, RH
8	32144-70	2	Screw-HWHTF	25	109-0273	1	Hose-Fuel
9	119-3324	1	Fuel Tank ASM	26	108-9698	1	Hose-Fuel
9:1	121-0793	1	Connector-Elbow, 90 DEG	27	2412-98	3	Clamp-Hose
9:2	46-6560	2	Bushing	28	614249	3	Tie-Cable
9:4	117-7400	1	Fitting-Plastic	29	117-5399	1	Adaptor-Orifice
10	3258-166	3	Screw-PRH	30	110-1876	1	Hose-Fuel

Battery and Electrical Assembly

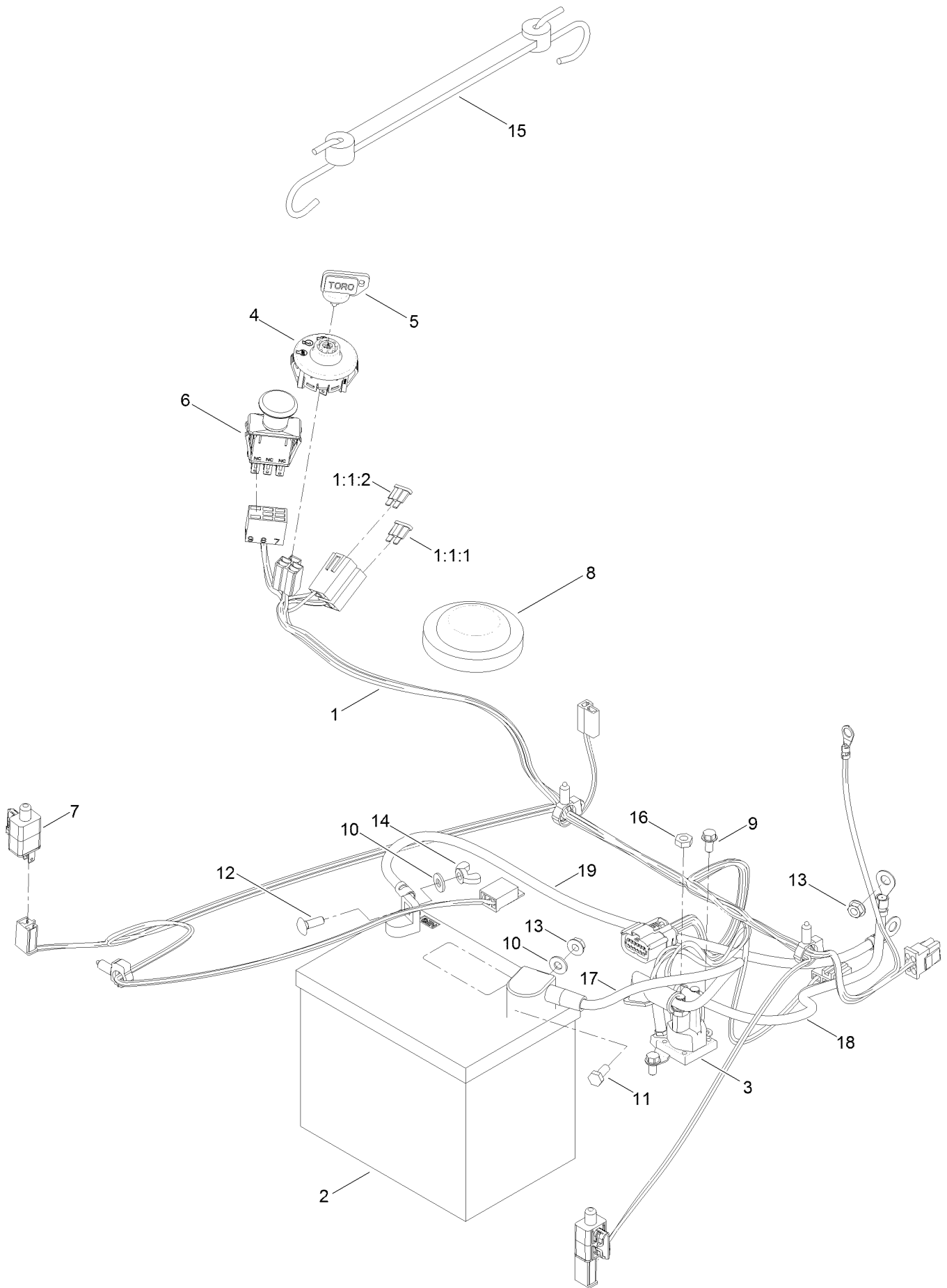

Battery and Electrical Assembly (continued)

<i>Ref.</i>	<i>Part Number</i>	<i>Qty.</i>	<i>Description</i>	<i>Ref.</i>	<i>Part Number</i>	<i>Qty.</i>	<i>Description</i>
1	136-7482	1	Harness-Wire	10	3256-22	2	Washer-Flat
1:1:1	109103	1	Fuse-Blade, 30 Amp	11	321-3	1	Screw-HH
1:1:2	109102	1	Fuse-Blade, 25 Amp	12	3229-1	1	Bolt-CARR
2	105-1692	1	Battery-Dry	13	32128-33	1	Nut-HF
3	117-1197	1	Solenoid	14	32103-22	1	Nut-Wing
4	117-2221	1	Switch-Ignition	15	104-2466	1	Holddown-Battery
5	63-8360	1	Key-Ignition	16	3220-2	2	Nut-Jam
6	103-5221	1	Switch-PTO	17	119-8897	1	Cable-Battery, Red
7	110-6765	2	Switch	18	121-0711	1	Cable-Battery, Positive
8	100-3524	1	Switch-Seat	19	121-5726	1	Cable-Battery, Black
9	32144-4	2	Screw-HWH	25	32128-33	1	Nut-HF ●

● Not illustrated

42 Inch Deck Assembly

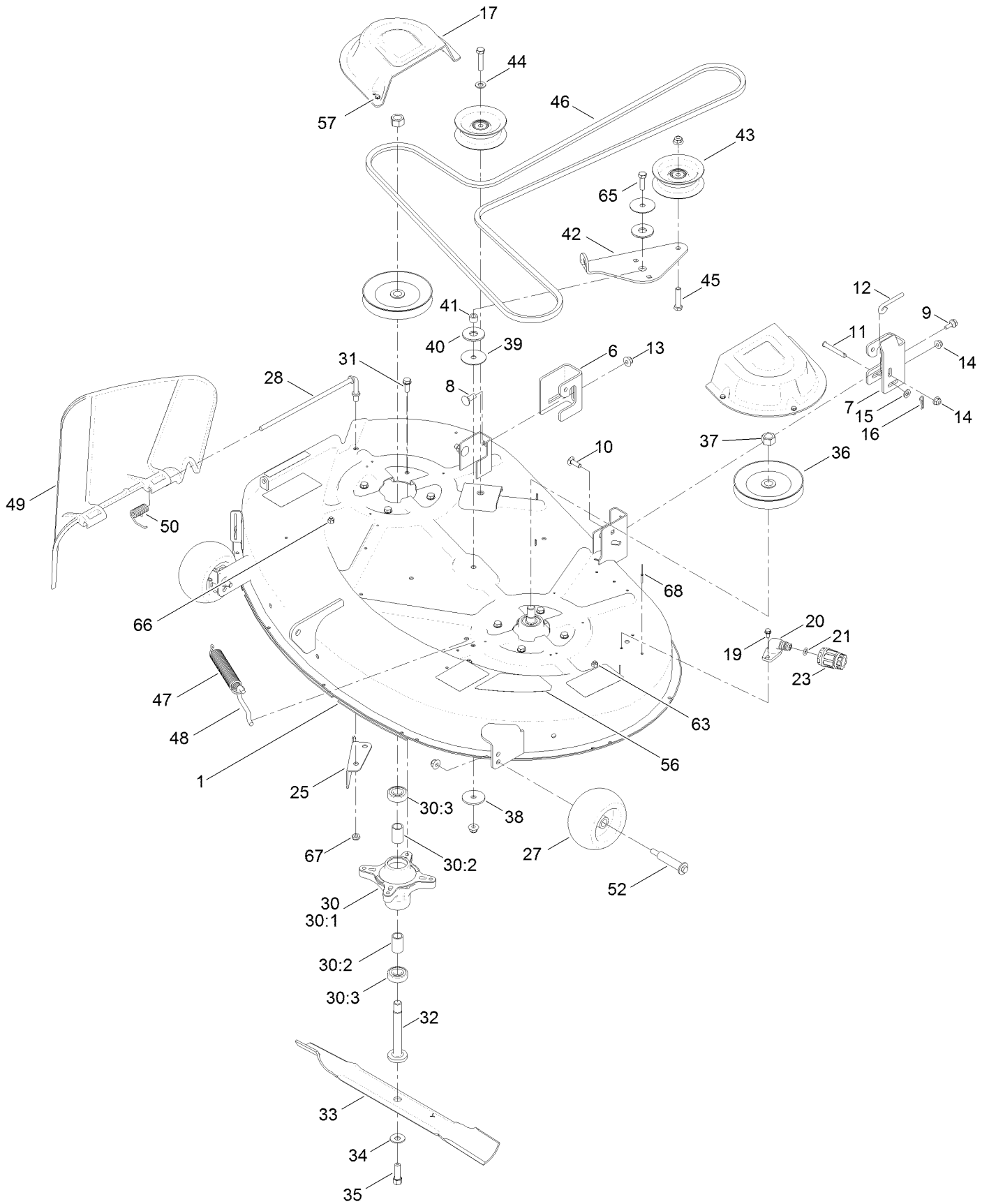

42 Inch Deck Assembly (continued)

<i>Ref.</i>	<i>Part Number</i>	<i>Qty.</i>	<i>Description</i>	<i>Ref.</i>	<i>Part Number</i>	<i>Qty.</i>	<i>Description</i>
1	131-3604	1	42 Inch Deck And Decal ASM	33	131-3939-03	2	Blade-High Lift
6	131-4138	1	Bracket-Hanger, RH	34	3290-465	2	Washer-Belleville
7	131-1091	1	Bracket-Hanger, LH	35	26-0671	2	Screw-HH
8	3231-2	2	Bolt-CARR	36	125-5574	2	Pulley
9	120-7024	1	Screw-Shoulder, HHF	37	3219-6	2	Nut-Hex
10	3230-22	1	Screw-CARR	38	63-7400	1	Washer-Rebound
11	110-0618	1	Pin-Clevis	39	120-2229	2	Washer
12	131-0955	1	Rod-Level, Deck	40	114-0463	2	Washer-Friction, Composite
13	104-8301	6	Nut-Flange, NI	41	115-4986	1	Spacer
14	104-8300	2	Nut-Flange, NI	42	114-8540	1	Arm-Idler
15	3256-23	1	Washer-Flat	43	106-2175	2	Pulley-Idler, Flat
16	1-806003	1	Pin-Cotter	44	3256-24	1	Washer-Flat
17	108-7889	2	Cover-Belt	45	323-9	2	Screw-HH
19	32144-4	2	Screw-HWH	46	119-8819	1	V-Belt
20	95-2747	1	Fitting-Washout	47	106-2177	1	Spring-Extension
21	46-6290	1	O-Ring	48	88-5970	1	Hook-Return, Spring
23	95-3270	1	Connector-Hose	49	112-3951	1	Deflector
25	112-3983-03	1	Baffle-Cutoff	50	110-6694	1	Spring-Torsion
27	1-603299	2	Roller-Scalp, Anti	52	112-3977	2	Bolt-Shoulder
28	112-4026	1	Rod-Pivot	56	117-1222	1	Decal
30	121-0751	2	Spindle ASM	57	32144-1	6	Screw-Taptite
30:1	117-7267	1	Spindle	63	3296-42	3	Nut-Lock, NI
30:2	120-7935	2	Spacer	65	323-7	1	Screw-HH
30:3	38-7820	2	Bearing-Ball	66	321-2	3	Screw-HH
31	32144-41	8	Screw-Taptite	67	3296-59	1	Nut-Lock, NI
32	117-7268	2	Shaft-Spindle	68	3290-282	2	Rivet-Blind

42 Inch Deck Assembly No. 131-3604

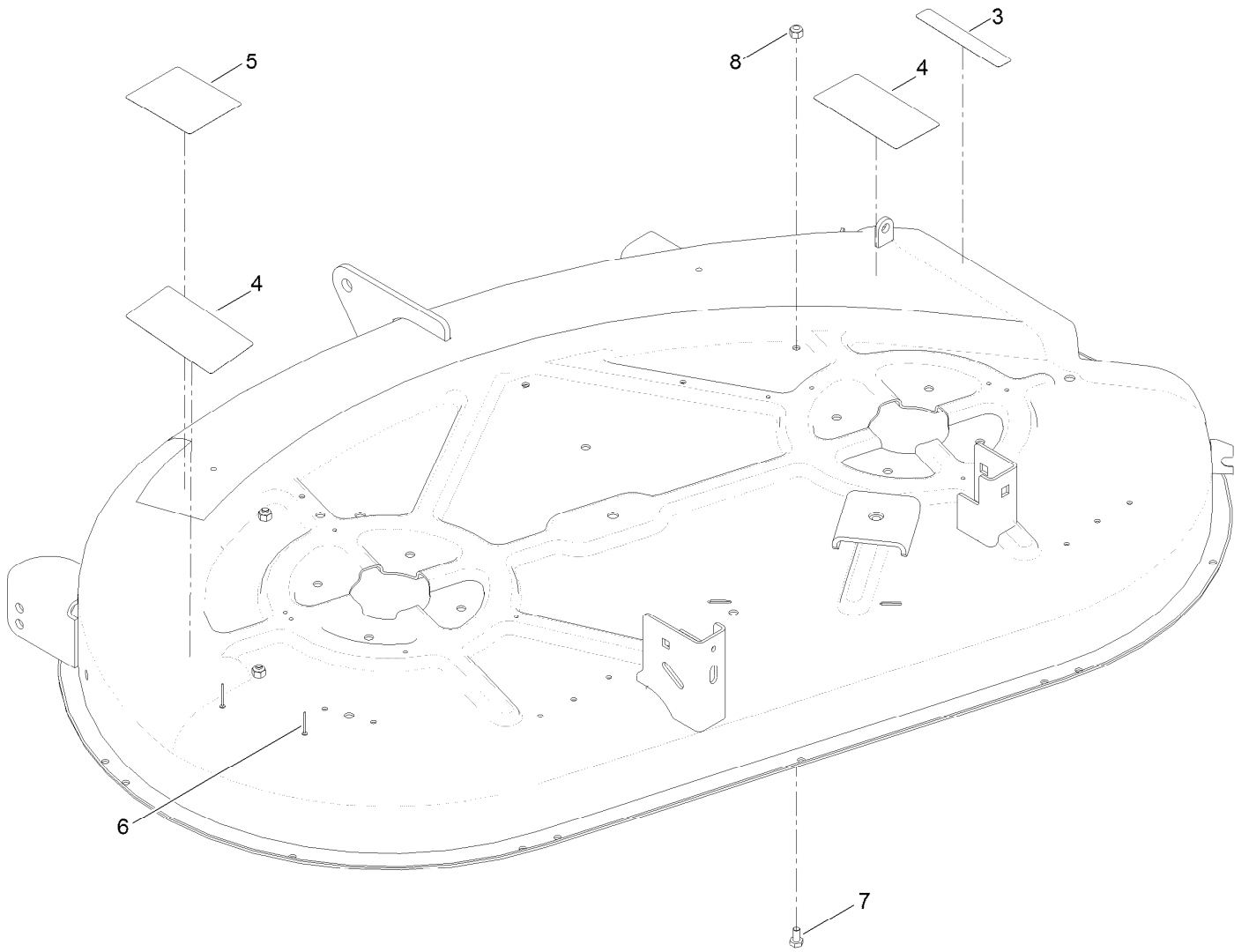

42 Inch Deck Assembly No. 131-3604 (continued)

<i>Ref.</i>	<i>Part Number</i>	<i>Qty.</i>	<i>Description</i>	<i>Ref.</i>	<i>Part Number</i>	<i>Qty.</i>	<i>Description</i>
3	93-7009	1	Decal-Danger	6	3290-282	2	Rivet-Blind
4	132-0872	2	Decal-Danger, Deck	7	321-2	3	Screw-HH
5	105-7015	1	Decal-Routing, Belt	8	3296-42	3	Nut-Lock, NI

Model Specific Decal Assembly

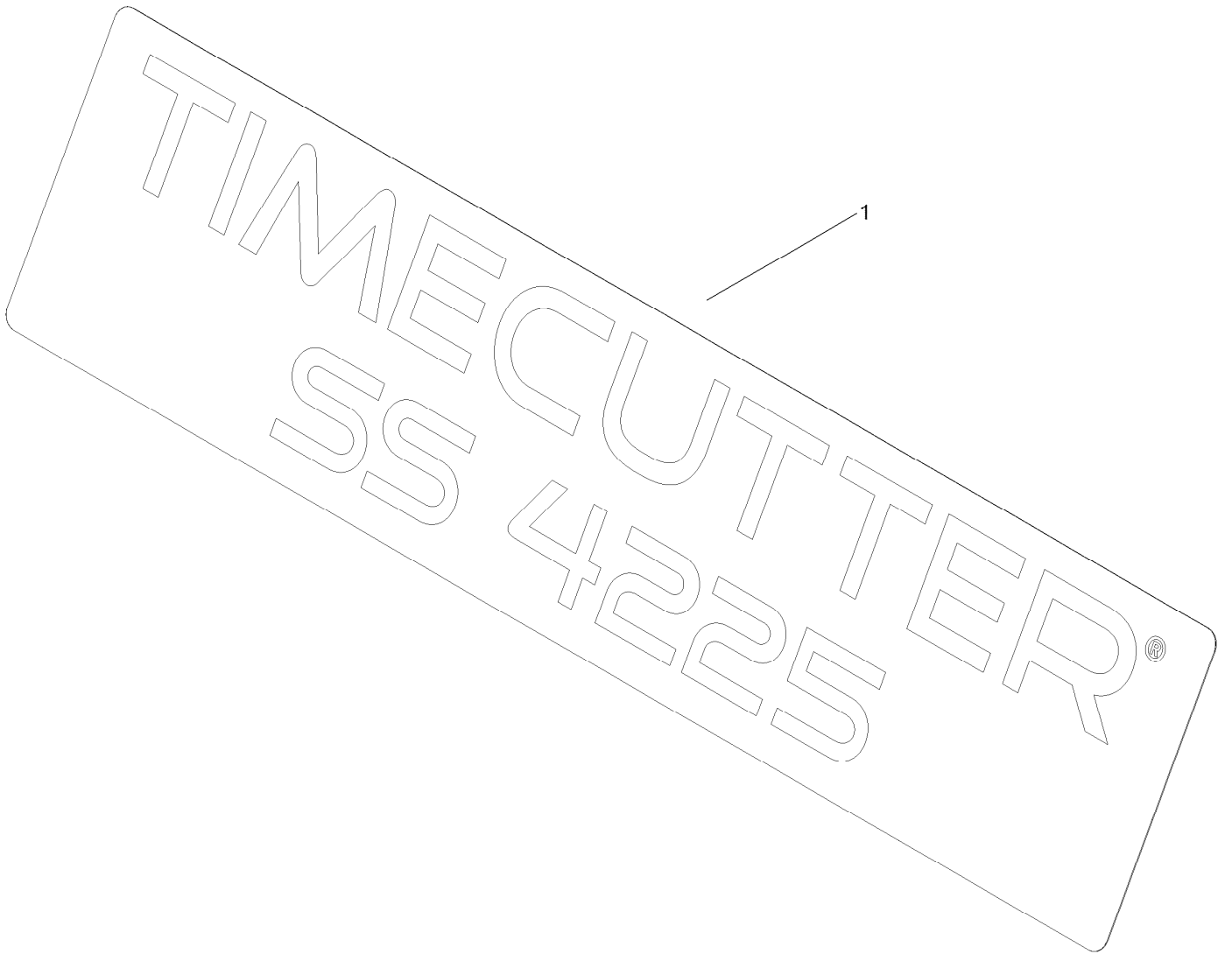

Model Specific Decal Assembly (continued)

<i>Ref.</i>	<i>Part Number</i>	<i>Qty.</i>	<i>Description</i>
1	131-3650	1	Decal-Timecutter

Speed Control, HOC and Service Decal Assembly

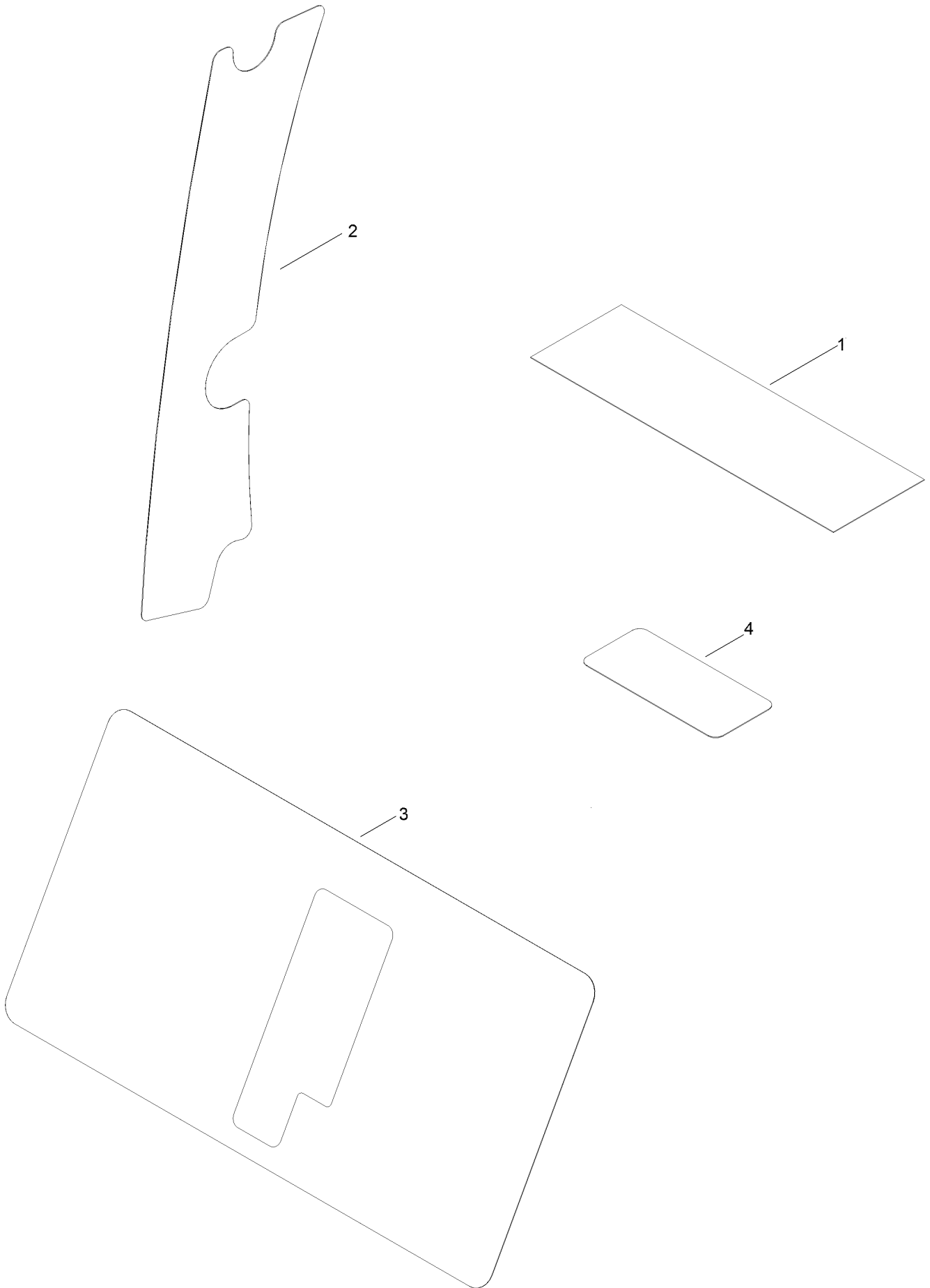

Speed Control, HOC and Service Decal Assembly (continued)

<i>Ref.</i>	<i>Part Number</i>	<i>Qty.</i>	<i>Description</i>	<i>Ref.</i>	<i>Part Number</i>	<i>Qty.</i>	<i>Description</i>
1	106-8717	1	Decal-Service	3	131-3947	1	Decal-Control, Speed
2	119-8871	1	Decal	4	121-5684	1	Decal-Location, Service Dealer

Clutch Assembly

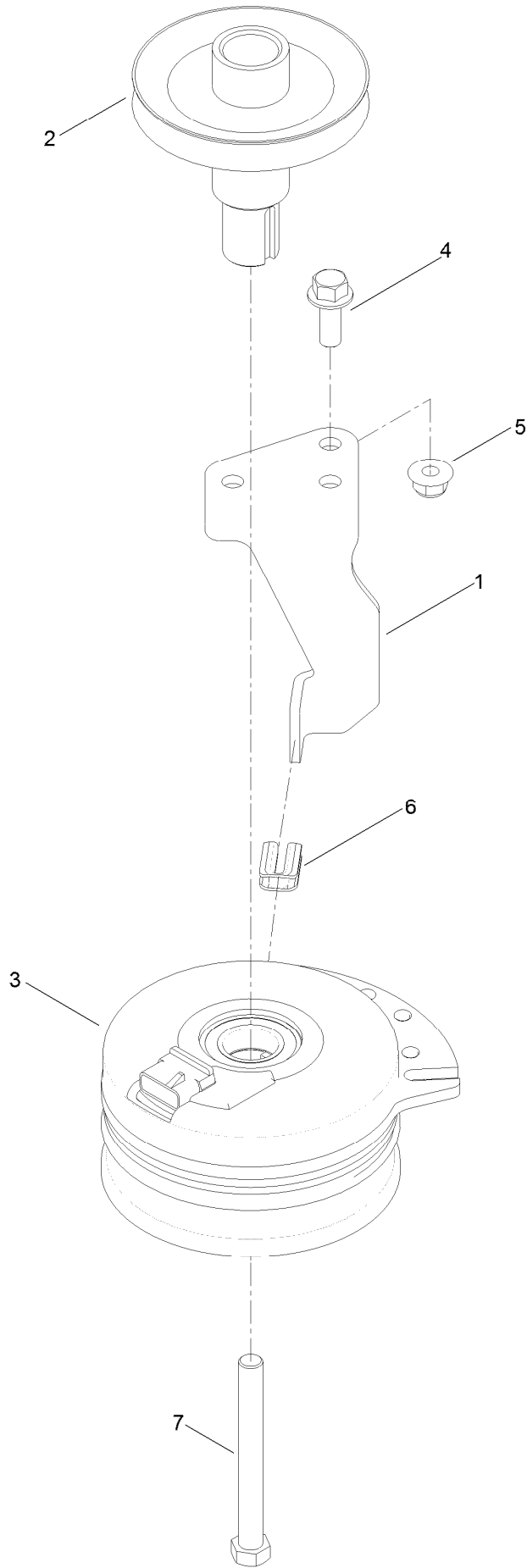

Clutch Assembly (continued)

<i>Ref.</i>	<i>Part Number</i>	<i>Qty.</i>	<i>Description</i>	<i>Ref.</i>	<i>Part Number</i>	<i>Qty.</i>	<i>Description</i>
1	119-8884	1	Stop-Clutch	5	104-8301	1	Nut-Flange, NI
2	130-6854	1	Pulley-Engine	6	120-2217	1	Isolator-Clutch
3	117-7468	1	Clutch-Electric	7	3212-16	1	Screw-HH
4	3234-42	1	Screw-HHF				

Attachments and Accessories

For 74721 TimeCutter SS 4225 Riding Mower

Product Name	Model/Part
Armrest Kit	105-6978
42in Blowout Ring Kit.....	114-1620
Hourmeter Kit	116-5461
All Season Synthetic Oil.....	117-0066
Fuel Stabilizer (4oz).....	117-0089
Fuel Stabilizer (16oz).....	117-0090
Seat Cover W/o Arm Rest - TC 18in	117-0096
Striping Kit	120-7905
Jack Mount Kit	126-5251
Jack Kit.....	127-6666
Replacement Blade Kit	131-3939-03P
Attachment Mount Kit	131-3966
42in Recycler Kit.....	131-4182
Weight Kit	131-7658
Deluxe Seat Kit	131-7699
Floor Mat Kit	132-6921
10w30 4-cycle Engine Oil (32oz Bottle)	38280
Toro 4-cycle Sae 30 Oil (32oz Bottle).....	38903
Storage Cover	490-7516
Foot Assist Deck Lift Kit, 2011 and After Zero-Turn-Radius Riding Mower	79010
Sunshade Kit	79011
Cargo Carrier.....	79040
Assist Handle and Step Kit	79339
42in Bagger	79391

Notes:

Notes:

Notes:



Count on it.