



**Count on it.**

**Operator's Manual**

**8 and 11-Blade 27-inch and  
8-Blade 32-inch Edge Series  
Cutting Unit**

**Reelmaster® 7000-D Traction Unit**

Model No. 03721—Serial No. 400000000 and Up

Model No. 03722—Serial No. 400000000 and Up

Model No. 03727—Serial No. 400000000 and Up



**⚠ WARNING**

**CALIFORNIA  
Proposition 65 Warning**

**This product contains a chemical or chemicals known to the State of California to cause cancer, birth defects, or reproductive harm.**

This product complies with all relevant European directives. For details, please see the Declaration of Incorporation (DOI) at the back of this publication.

# Introduction

Read this information carefully to learn how to operate and maintain your product properly and to avoid injury and product damage. You are responsible for operating the product properly and safely.

You may contact Toro directly at [www.Toro.com](http://www.Toro.com) for product safety and operation training materials, accessory information, help finding a dealer, or to register your product.

Whenever you need service, genuine Toro parts, or additional information, contact an Authorized Service Dealer or Toro Customer Service and have the model and serial numbers of your product ready. [Figure 1](#) identifies the location of the model and serial numbers on the product. Write the numbers in the space provided.

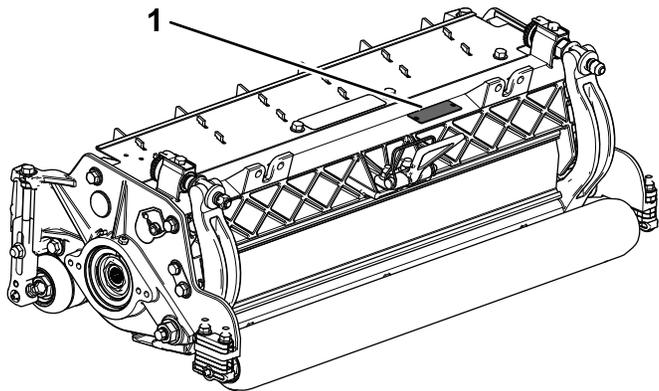

**Figure 1**

- 1. Location of the model and serial numbers

Model No. \_\_\_\_\_  
Serial No. \_\_\_\_\_

This manual identifies potential hazards and has safety messages identified by the safety-alert symbol ([Figure 2](#)),

which signals a hazard that may cause serious injury or death if you do not follow the recommended precautions.



**Figure 2**

g000502

- 1. Safety-alert symbol

This manual uses 2 words to highlight information.

**Important** calls attention to special mechanical information and **Note** emphasizes general information worthy of special attention.

# Contents

Safety ..... 3  
    Safety and Instructional Decals ..... 3  
Setup ..... 4  
    1 Inspect the Cutting Unit..... 4  
    2 Using the Kickstand When Tipping the Cutting Unit ..... 4  
    3 Adjusting the Rear Shield ..... 5  
    4 Installing the Loose Parts ..... 5  
    5 Adjusting the Cutting-Unit Steering..... 6  
Product Overview ..... 7  
    Specifications ..... 7  
    Attachments/Accessories..... 7  
Operation ..... 7  
    Making Adjustments..... 7  
    Height-of-Cut Chart Terms ..... 9  
    Height-of-Cut Chart ..... 11  
    Adjusting the Height of Cut (HOC)..... 12  
    Adjusting the Turf-Compensation Settings..... 13  
    Checking and Adjusting the Cutting Unit ..... 13  
Maintenance ..... 15  
    Lubricating the Cutting Unit ..... 15  
    Relief-Grinding the Reel..... 15  
    Servicing the Bedknife ..... 16  
    Servicing the Bedbar ..... 17  
    Servicing the HD Dual Point Adjusters (DPA) ..... 19  
    Servicing the Roller..... 20

# Safety

This machine has been designed in accordance with EN ISO 5395:2013 and ANSI B71.4-2012.

**Improper use or maintenance of this equipment can result in injury or death. To reduce the potential for injury or death, comply with the following safety instructions.**

- Read, understand, and follow all instructions in the traction unit *Operator's Manual* before operating the cutting unit.
- Read, understand, and follow all instructions in this *Operator's Manual* before operating the cutting unit.
- Never allow children to operate the traction unit or cutting units. Do not allow adults to operate the traction unit or the cutting units without proper instruction. Only trained operators who have read this *Operator's Manual* should operate the cutting units.
- Never operate the cutting units when tired, ill, or under the influence of drugs or alcohol.
- Keep all shields and safety devices in place. If a shield, a safety device, or a decal is illegible or damaged, repair or replace it before resuming operation. Also, tighten any loose nuts, bolts, and screws to ensure that the cutting unit is in safe operating condition.
- Wear appropriate clothing, including eye protection; substantial, slip-resistant footwear; and hearing protection. Wearing safety shoes and long pants is

advisable and required by some local ordinances and insurance regulations. Secure loose clothing.

- Tie back long hair. Do not wear jewelry.
- Remove all debris or other objects that might be picked up and thrown by the reel blades of the cutting unit. Keep all bystanders away from the working area.
- If the cutting blades strike a solid object or the unit vibrates abnormally, stop and shut off the engine. Check the cutting unit for damaged parts. Repair any damage before starting and operating the cutting unit.
- Lower the cutting units to the ground, engage the parking brake, shut off the engine, and remove the key from the ignition switch whenever you leave the machine unattended.
- Ensure that the cutting units are in safe operating condition by keeping nuts, bolts, and screws tight.
- Remove the key from the switch to prevent accidental starting of the engine when servicing, adjusting, or storing the machine.
- Perform only those maintenance instructions described in this manual. If major repairs are ever needed or assistance is desired, contact an Authorized Toro Distributor.
- To ensure optimum performance and continued safety certification of the machine, use only genuine Toro replacement parts and accessories. Replacement parts and accessories made by other manufacturers could be dangerous, and such use could void the product warranty.

## Safety and Instructional Decals



Safety decals and instructions are easily visible to the operator and are located near any area of potential danger. Replace any decal that is damaged or lost.



93-6688

1. Warning—read the *Operator's Manual* before performing maintenance.
2. Cutting hazard of hand or foot—shut off the engine and wait for all moving parts to stop.

# Setup

## Loose Parts

Use the chart below to verify that all parts have been shipped.

Procedure	Description	Qty.	Use
<b>1</b>	Cutting unit	1	Inspect the cutting unit.
<b>2</b>	No parts required	–	Use the kickstand when tipping the cutting unit.
<b>3</b>	No parts required	–	Adjust the rear shield.
<b>4</b>	Straight grease fitting O-ring	1 1	Install the loose parts.
<b>5</b>	No parts required	–	Adjust the cutting-unit steering.

## Media and Additional Parts

Description	Qty.	Use
Operator's Manual	1	Review the materials and keep them in an appropriate place.
O-ring	1	Use these when mounting reel motor to cutting unit.
Screws	2	Use these to mount reel motor to cutting unit.

**Note:** Determine the left and right sides of the machine from the normal operating position.

# 1

## Inspect the Cutting Unit

Parts needed for this procedure:

1	Cutting unit
---	--------------

## Procedure

After the cutting unit is removed from the box, inspect the following:

1. Check each end of the reel for grease.
2. Ensure that all nuts and bolts are securely tightened.
3. Make sure that the carrier frame suspension operates freely and does not bind when it is moved back and forth.

# 2

## Using the Kickstand When Tipping the Cutting Unit

No Parts Required

## Procedure

Whenever you have to tip the cutting unit to expose the bedknife/reel, prop up the rear of the cutting unit with the kickstand (supplied with the traction unit) to make sure that the nuts on the back end of the bedbar-adjusting screws are not resting on the work surface ([Figure 3](#)).

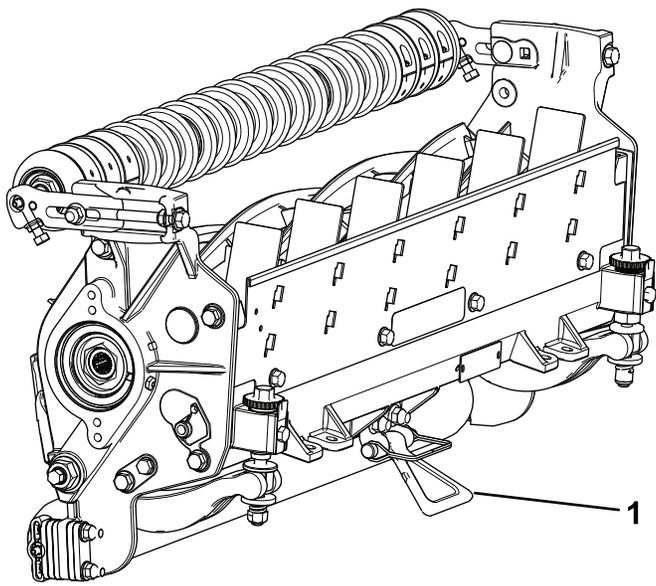

Figure 3

g191340

1. Cutting unit kickstand

# 3

## Adjusting the Rear Shield

### No Parts Required

### Procedure

Under most conditions, the best dispersion is attained when the rear shield is closed (front discharge). When conditions are heavy or wet, the rear shield may be opened.

To open the rear shield (Figure 4), loosen the bolt securing the shield to the left side plate, rotate the shield to the open position, and tighten the bolt.

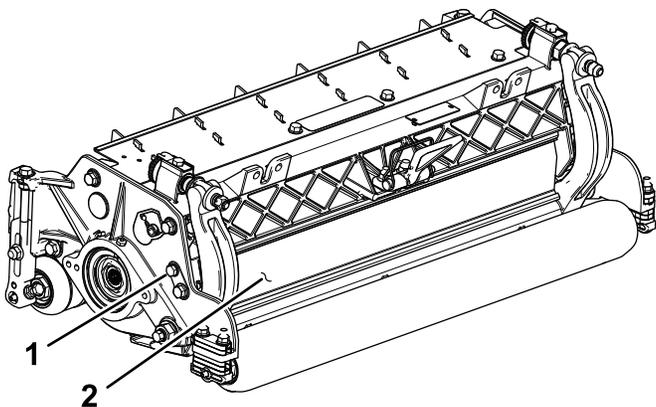

Figure 4

g191341

1. Bolt
2. Rear shield

# 4

## Installing the Loose Parts

### Parts needed for this procedure:

1	Straight grease fitting
1	O-ring

### Procedure

The grease fitting must be installed on the reel-motor side of the cutting unit. Refer to Figure 5 to determine the position of the reel motors.

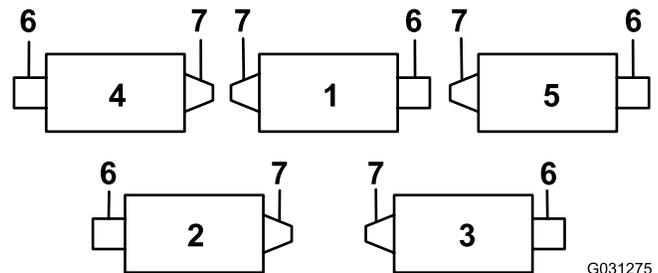

G031275  
g031275

Figure 5

1. Cutting unit 1
2. Cutting unit 2
3. Cutting unit 3
4. Cutting unit 4
5. Cutting unit 5
6. Reel motor
7. Weight

1. Remove and discard the setscrew on the reel-motor side plate (Figure 6).

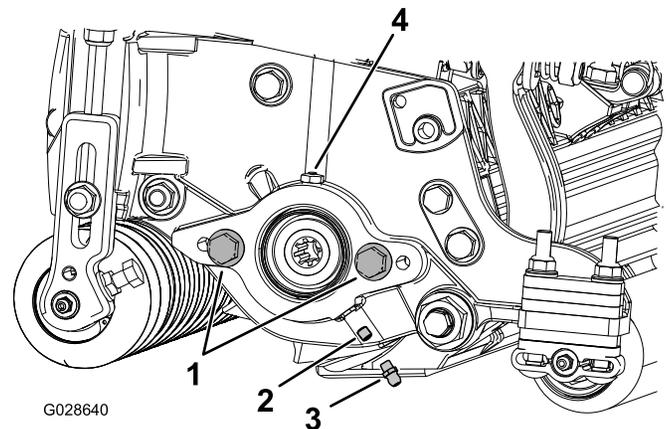

G028640

g028640

Figure 6

1. Cap screw (2)
2. Setscrew
3. Grease fitting
4. Grease vent

2. Install the straight grease fitting (Figure 6).
3. If there are no cap screws on the reel-motor side plate, install them (Figure 6).

4. Install the O-ring on the reel motor (Figure 7).

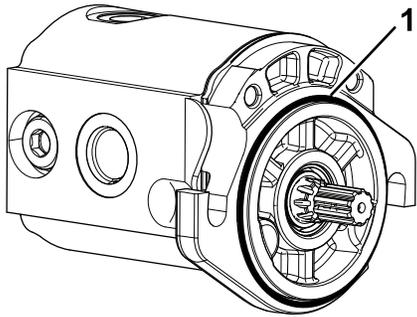
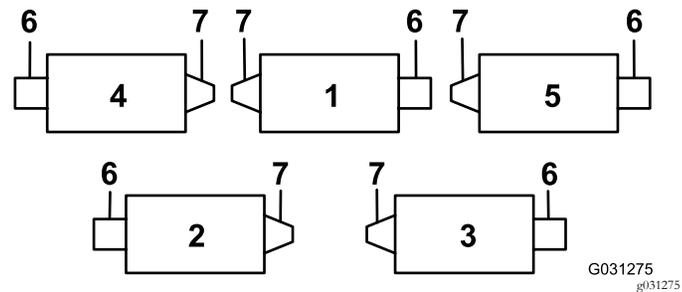

Figure 7

g191072

1. O-ring

5. Install the reel motor, and grease the side plate until excess grease comes out of the grease vent (Figure 6).



G031275  
g031275

Figure 9

- |                   |                   |
|-------------------|-------------------|
| 1. Cutting unit 1 | 5. Cutting unit 5 |
| 2. Cutting unit 2 | 6. Reel motor     |
| 3. Cutting unit 3 | 7. Weight         |
| 4. Cutting unit 4 |                   |

# 5

## Adjusting the Cutting-Unit Steering

No Parts Required

### Increased Steering for the Rear Cutting Units

Increase the steering on the rear cutting units by removing the 2 pivot spacers, hex socket screws, and flange locknuts (Figure 8) from the carrier frames of the rear cutting units (cutting units 2 and 3); refer to Figure 9.

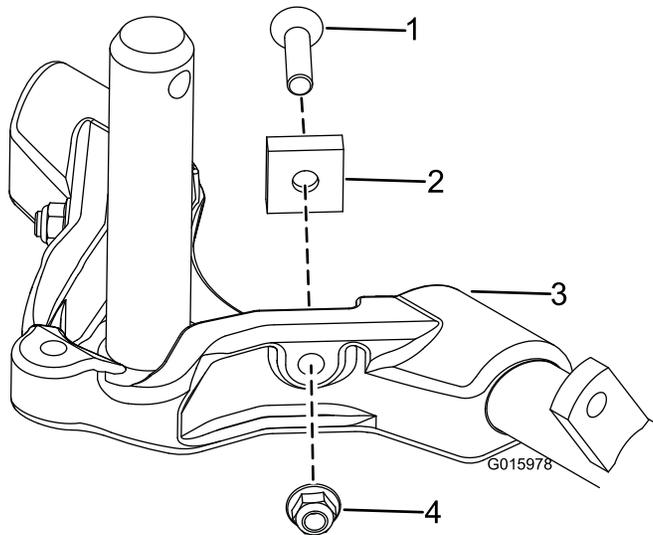

Figure 8

g015978

- |                     |                   |
|---------------------|-------------------|
| 1. Hex socket screw | 3. Carrier frame  |
| 2. Pivot spacer     | 4. Flange locknut |

## Locking the Steering

To lock (fix) the steering on the cutting units, secure the pivot yoke to the carrier frame with the snapper pin (Figure 10).

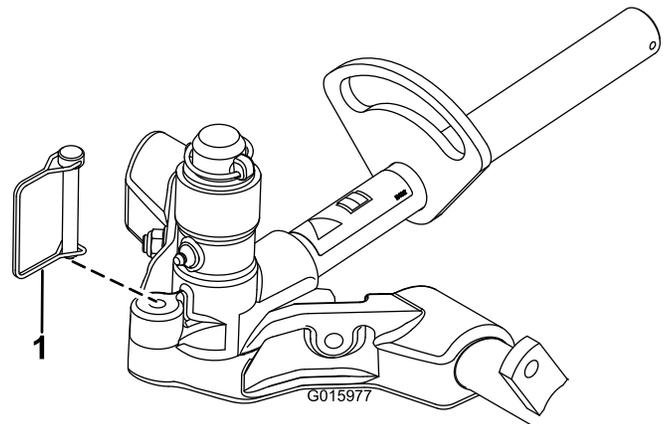

G015977

Figure 10

g015977

1. Snapper pin

**Note:** Fixed steering is recommended when cutting side hills.

# Product Overview

## Specifications

Cutting Unit	Weight
27 inch, 8 blade	66 kg (145 lb)
27 inch, 11 blade	68 kg (150 lb)
32 inch, 8 blade	74 kg (162 lb)

## Attachments/Accessories

A selection of Toro-approved attachments and accessories is available for use with the machine to enhance and expand its capabilities. Contact your Authorized Service Dealer or Distributor or go to [www.Toro.com](http://www.Toro.com) for a list of all approved attachments and accessories.

To best protect your investment and maintain optimal performance of your Toro equipment, count on Toro genuine parts. When it comes to reliability, Toro delivers replacement parts designed to the exact engineering specification of our equipment. For peace of mind, insist on Toro genuine parts.

## Operation

**Note:** Determine the left and right sides of the machine from the normal operating position.

## Making Adjustments

### Adjusting the Bedknife to the Reel

Use this procedure to set the bedknife to the reel and to check the condition of the reel and bedknife and their interaction. After completing this procedure, always test the cutting unit performance under your field conditions. You may need to make further adjustments to obtain optimal cutting performance.

**Important:** Do not overtighten the bedknife to the reel or you will damage it.

- After backlapping the cutting unit or grinding the reel, you may need to mow with the cutting unit for a few minutes and then perform this procedure to adjust the bedknife to the reel as the reel and bedknife adjust to each other.
- You may need additional adjustments if the turf is extremely dense or your cutting height is very low.

You will need the following tools to complete this procedure:

- Shim 0.0508 mm (0.002 inch)—Toro Part No. 125-5611
  - Cutting performance paper—Toro Part No. 125-5610
1. Turn the bedbar-adjusting screws counterclockwise to ensure that the bedbar does not contact the reel ([Figure 11](#)).

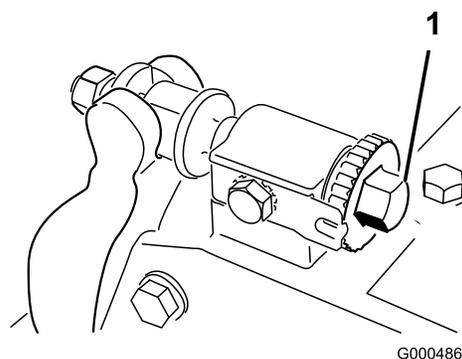
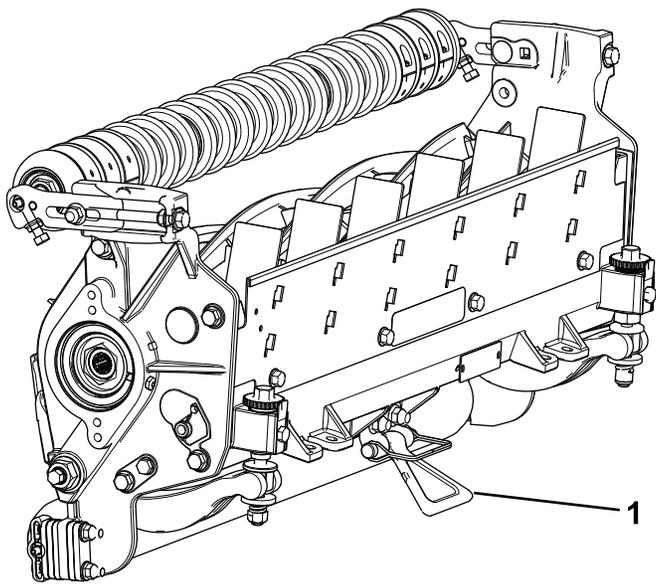

**Figure 11**

1. Bedbar-adjusting screw

2. Tip the cutting unit to expose the bedknife and the reel.

**Important:** Ensure that the nuts on the back end of the bedbar-adjusting screws are not resting on the work surface; use the kickstand ([Figure 12](#)).



**Figure 12**

g191340

1. Kickstand

3. Rotate the reel so that a blade crosses the bedknife approximately 25 mm (1 inch) in from the end of the bedknife on the right side of the cutting unit.

**Note:** Put an identifying mark on this blade to make subsequent adjustments easier.

4. Insert the 0.05 mm (0.002 inch) shim between the marked reel blade and the bedknife at the point where the blade crosses the bedknife.
5. Turn the right bedbar adjuster clockwise until you feel **light** pressure (i.e., drag) on the shim, then back off the bedbar adjuster 2 clicks and remove the shim.

**Note:** Adjusting 1 side of the cutting unit affects the other side, the 2 clicks provide clearance for when the other side is adjusted.

**Note:** If starting with a large gap, both sides should initially be drawn closer by alternately tightening the right and left sides.

6. **Slowly** rotate the reel so that the same blade that you checked on the right side is crossing the bedknife approximately 25 mm (1 inch) in from the end of the bedknife on the left side of the cutting unit.
7. Turn the left bedbar adjuster clockwise until the shim can be slid through the reel to bedknife gap with light drag.
8. Return to the right side and adjust as necessary to get light drag on the shim between the same blade and bedknife.
9. Repeat steps 6 and 7 until the shim can be slid through both gaps with slight drag, but 1 click in on both sides prevents the shim from passing through on both sides.

**Note:** The bedknife is now parallel to the reel.

**Note:** This procedure should not be needed on daily adjustments, but should be done after grinding or disassembly.

10. From this position (i.e., 1 click in and shim not passing through) turn the bedbar adjusters clockwise 1 click each.

**Note:** Each click turned moves the bedknife 0.022 mm (0.0009 inch). **Do not overtighten the adjusting screws.**

11. Test the cutting performance by inserting a long strip of cutting performance paper (Toro Part No. 125-5610) between the reel and the bedknife, perpendicular to the bedknife (Figure 13).

**Note:** **Slowly** rotate the reel forward; it should cut the paper.

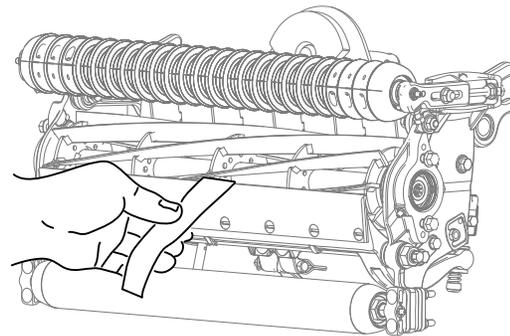

**Figure 13**

g027166

g027166

**Note:** If excessive reel drag occurs either backlap or grind the cutting unit to achieve the sharp edges needed for precision cutting.

## Adjusting the Rear Roller

1. Adjust the rear roller brackets (Figure 14) to the desired height-of-cut range by positioning the required amount of spacers below the side-plate mounting flange (Figure 14) per the HOC Chart.

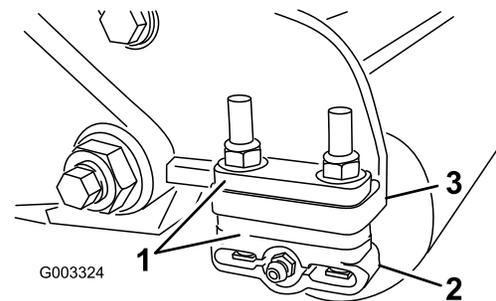

**Figure 14**

G003324

g003324

1. Spacer
2. Roller bracket
3. Side-plate mounting flange

2. Raise the rear of the cutting unit and place a block under the bedknife.

3. Remove the 2 nuts securing each roller bracket and spacer to each side-plate mounting flange.
4. Lower the roller and screws from the side-plate mounting flanges and spacers.
5. Place the spacers onto the screws on the roller brackets.
6. Secure the roller bracket and spacers to the underside of the side-plate mounting flanges with the nuts previously removed.
7. Verify that the bedknife-to-reel contact is correct. Tip the cutting unit to expose the front and rear rollers and the bedknife.

**Note:** The position of the rear roller to the reel is controlled by the machining tolerances of the assembled components and paralleling is not required. A limited amount of adjustment is possible by setting the cutting unit on a surface plate and loosening the side-plate mounting bolts (Figure 15). Adjust and tighten bolts. Torque the bolts to 37 to 45 N·m (27 to 33 ft-lb).

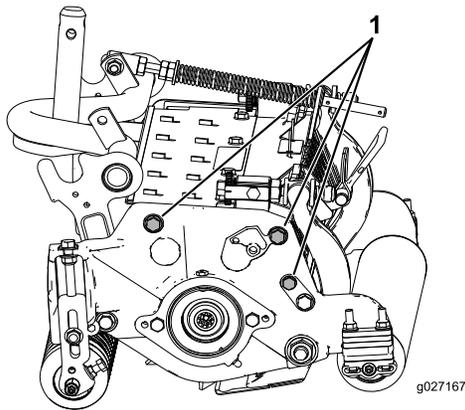

**Figure 15**

1. Side-plate mounting bolts

soil conditions. The cutting unit setup (aggressiveness of cut, rollers, bedknives, attachments installed, turf compensation settings, etc.) will also affect the effective height of cut. Check the effective height of cut using the Turf Evaluator (Model 04399) regularly to determine the desired bench set height of cut.

## Aggressiveness of Cut

Aggressiveness of cut has a significant impact on the performance of the cutting unit. Aggressiveness of cut refers to the angle of the bedknife relative to the ground (Figure 16).

The best cutting unit setup is dependent on your turf conditions and desired results. Experience with the cutting unit on your turf will determine the best setting to use. Aggressiveness of cut may be adjusted throughout the cutting season to allow for various turf conditions.

In general, less to normal aggressive settings are more appropriate for warm-season grasses (Bermuda, paspalum, zoysia) while cool-season grasses (bent, bluegrass, rye) may require normal to more aggressive setups. More aggressive setups cut more grass off by allowing the spinning reel to pull more grass up into the bedknife.

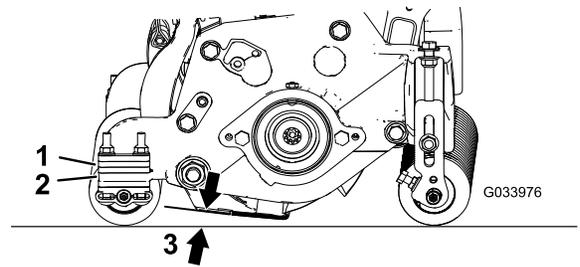

**Figure 16**

1. Rear spacers
2. Side-plate mounting flange
3. Aggressiveness of cut

## Height-of-Cut Chart Terms

### Height-of-Cut Setting (HOC)

This corresponds to the desired height of cut.

### Bench-Set Height of Cut

The bench-set height of cut is the height at which the top edge of the bedknife is set above a flat level surface that contacts the bottom of both the front and rear roller.

### Effective Height of Cut

This is the actual height that the grass has been cut. For a given bench set height of cut, the actual height of cut will vary depending on the type of grass, time of year, turf, and

## Rear Spacers

The number of rear spacers determines the aggressiveness of cut for the cutting unit. For a given height of cut, adding spacers below the side-plate mounting flange increases the aggressiveness of the cutting unit. All cutting units on a given machine must be set to the same aggressiveness of cut (number of rear spacers, Part No. 106-3925); otherwise, the after-cut appearance could be negatively affected (Figure 16).

## Chain Links

The location at which the lift-arm chain is attached determines the pitch angle of the rear roller (Figure 17).

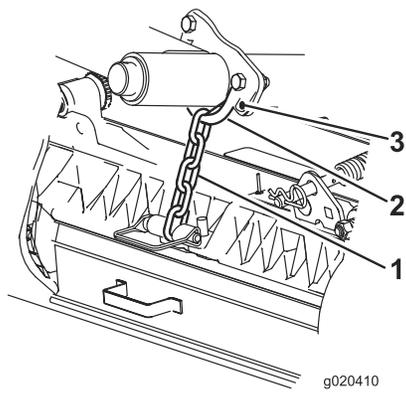

g020410

**Figure 17**

- 1. Lift chain
  - 2. U bracket
  - 3. Bottom hole
- 

## Groomer

These are the recommended height-of-cut settings when a groomer kit is installed on the cutting unit.

# Height-of-Cut Chart

HOC Setting	Aggressiveness of Cut	No. of Rear Spacers	No. of Chain Links	With Groomer Kits Installed
0.64 cm (0.250 inch)	Less	0	5+	Y
	Normal	0	5+	Y
	More	1	5+	-
0.95 cm (0.375 inch)	Less	0	5+	Y
	Normal	1	5+	Y
	More	2	5+	-
1.27 cm (0.500 inch)	Less	0	6	Y
	Normal	1	5+	Y
	More	2	5+	Y
1.59 cm (0.625 inch)	Less	1	6	Y
	Normal	2	5+	Y
	More	3	5+	-
1.91 cm (0.750 inch)	Less	2	6	Y
	Normal	3	5+	Y
	More	4	6	-
2.22 cm (0.875 inch)	Less	2	6	Y
	Normal	3	6	Y
	More	4	5+	-
2.54 cm (1.000 inch)	Less	3	6	Y
	Normal	4	5+	Y
	More	5	5+	-
2.86 cm (1.125 inches)	Less	4	6	-
	Normal	5	5	-
	More	6	5	-
3.18 cm (1.250 inches)	Less	4	6	-
	Normal	5	6	-
	More	6	6	-
3.49 cm (1.375 inches)	Less	4	6	-
	Normal	5	6	-
	More	6	6	-
3.81 cm (1.500 inches)	Less	5	6	-
	Normal	6	6	-
	More	7	6	-
4.13 cm (1.625 inches)	Less	6	5	-
	Normal	7	5	-
	More	8	5	-
4.44 cm (1.750 inches)	Less	6	5	-
	Normal	7	5	-
	More	8	6	-
4.76 cm (1.875 inches)	Less	7	5	-
	Normal	8	6	-
	More	9	6	-
5.08 cm (2.000 inches)	Less	7	6	-
	Normal	8	6	-
	More	9	6	-
5.40 cm (2.125 inches)	Less	8	6	-
	Normal	9	6	-
	More	10	6	-
5.71 cm (2.250 inches)	Less	8	6	-
	Normal	9	6	-
	More	10	6	-
6.03 cm (2.375 inches)	Less	9	6	-
	Normal	10	6	-
	More	11	6	-

6.35 cm (2.500 inches)	Less Normal More	9 10 11	6 6 6	- - -
------------------------	------------------------	---------------	-------------	-------------

+ indicates that the U bracket, on the lift arm, is positioned in the bottom hole (Figure 17).  
 "Y" indicates that this combination of HOC and spacers can be used with 27-inch groomers.

**Note:** Changing 1 chain link changes the rear-roller pitch angle movement by 4.5 degrees.

**Note:** Changing the U bracket (Figure 17), on the lift arm to the bottom hole adds 2.3 degrees to the rear-roller pitch angle.

## Adjusting the Height of Cut (HOC)

- Loosen the locknuts securing the height-of-cut arms to the cutting-unit side plates (Figure 18).

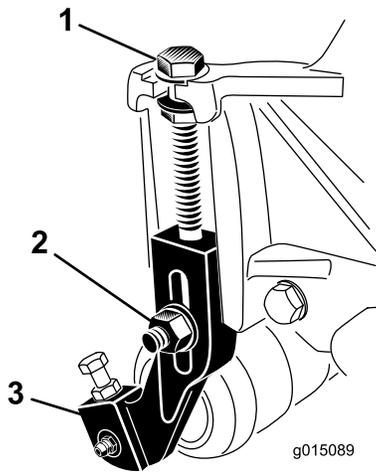

**Figure 18**  
8-blade cutting unit shown

- Adjusting screw
- Locknut
- Height-of-cut arm

- Loosen the nut on the gauge bar (Figure 19) and set the adjusting screw to the desired height of cut.

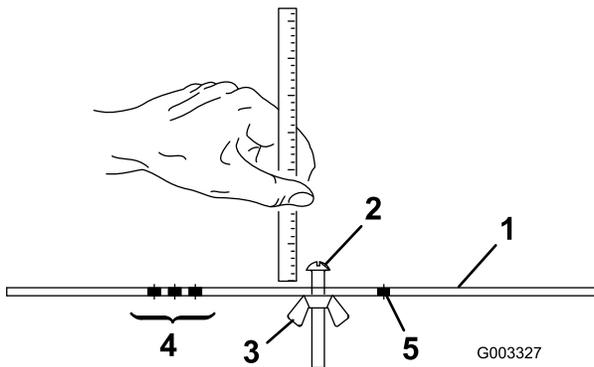

**Figure 19**

- Gauge bar
- Height-adjusting screw
- Nut
- Holes used for setting groomer HOG
- Hole not used

- Measure the distance between the bottom of the screw head and the face of the bar to get the height of cut.
- Hook the screw head on the cutting edge of the bedknife and rest the rear end of the bar on the rear roller (Figure 20).

**Note:** For checking the HOC on cutting units installed with shoulder rollers, place the gauge bar on the larger-diameter shoulders on the ends of the shoulder roller.

- Rotate the adjusting screw until the front roller contacts the gauge bar (Figure 20).

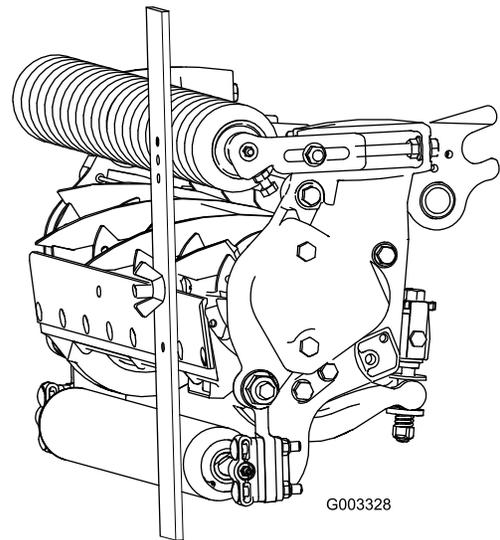

**Figure 20**

**Important:** When set properly, the rear and front rollers contact the gauge bar and the screw is snug against the bedknife. This ensures that the height of cut is identical at both ends of the bedknife.

- Adjust both ends of the roller until the entire roller is parallel to the bedknife.
- Tighten the nuts to secure the adjustment.

**Note:** Do not overtighten the nuts. Tighten them just enough to remove play from the washer.

Use the following chart to determine which bedknife is best suited for the desired height of cut.

Bedknife/Height of Cut Chart			
Bedknife	Part No.	Bedknife Lip Height *	Height of Cut
Low HOC (Optional)	120-1641 (27 inch) 120-1642 (32 inch)	5.6 mm (0.220 inch)	6.4 to 12.7 mm (0.250 to 0.500 inch)
EdgeMax® (Optional)	112-8910 (27 inch) 112-8956 (32 inch)	6.9 mm (0.270 inch)	9.5 to 63.5 mm (0.375 to 2.50 inches)*
Standard (Production)	114-9388 (27 inch) 114-9389 (32 inch)	6.9 mm (0.270 inch)	9.5 to 63.5 mm (0.375 to 2.50 inches)*
Heavy Duty (Optional)	114-9390 (27 inch) 114-9391 (32 inch)	9.3 mm (0.370 inch)	12.7 to 63.5 mm (0.500 to 2.50 inches)

**Note:** \* Warm-season grasses may require the Low HOC bedknife for 12.7 mm (0.500 inch) and below.

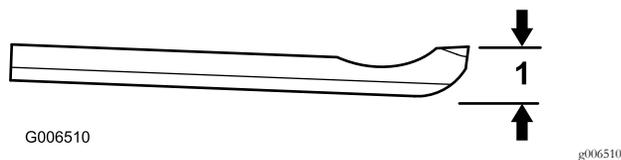

**Figure 21**

1. Bedknife lip height \*

## Adjusting the Turf-Compensation Settings

The turf-compensation spring transfers the weight from the front to the rear roller. This helps to reduce a wave pattern in the turf, also known as marcelling or bobbing.

**Important:** Make the spring adjustments with the cutting unit mounted to the traction unit, pointing straight ahead and lowered to the shop floor.

1. Make sure that the hairpin cotter is installed in the rear hole in the spring rod (Figure 22).

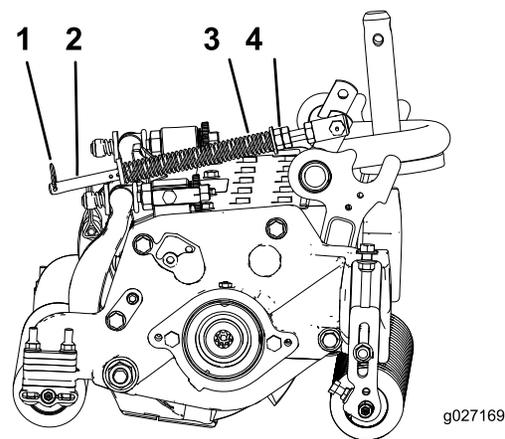

**Figure 22**

1. Turf-compensation spring
2. Hairpin cotter
3. Spring rod
4. Hex nuts

2. Tighten the hex nuts on the front end of the spring rod until the compressed length of the spring is 15.9 cm (6.25 inches) (Figure 22).

**Note:** When operating the machine on rough terrain, decrease the spring length by 12.7 mm (1/2 inch).

**Note:** The turf-compensation setting will need to be reset if the HOC setting or the aggressiveness-of-cut setting is changed.

## Checking and Adjusting the Cutting Unit

The dual-knob bedknife-to-reel adjustment system incorporated in this cutting unit simplifies the adjustment procedure needed to deliver optimum mowing performance. The precise adjustment possible with the dual knob/bedbar design gives the necessary control to provide a continual self-sharpening action—thus maintaining sharp cutting edges, ensuring good quality of cut, and greatly reducing the need for routine backlapping.

Prior to mowing each day, or as required, check each cutting unit to verify proper bedknife-to-reel contact. **This must be performed regardless of whether the quality of cut is acceptable.**

1. Lower the cutting units onto a hard surface, shut off the engine, and remove the ignition key.
2. Slowly rotate the reel in a reverse direction, listening for reel-to-bedknife contact. If no contact is evident, turn the bedknife-adjusting knobs clockwise, 1 click at a time, until you feel and hear light contact.

**Note:** The reel must cut a sheet of paper, when inserted at a right angle to the bedknife, at both ends and the center of the reel.

**Note:** The adjustment knobs have detents corresponding to 0.022 mm (0.0009 inch) bedknife movement for each indexed position.

3. If excessive contact/reel drag is evident, either backlap, reface the front of the bedknife, or grind the cutting unit to achieve the sharp edges needed for precision cutting; refer to the *Toro Manual for Sharpening Reel and Rotary Mowers* (Form No. 09168SL).

**Important:** Light contact is preferred at all times. If light contact is not maintained, the bedknife/reel edges will not sufficiently self-sharpen and dull cutting edges will result after a period of operation. If excessive contact is maintained, bedknife/reel wear will be accelerated, uneven wear can result, and quality of cut may be adversely affected.

**Note:** As the reel blades continue to run against the bedknife, a slight burr will appear on the front cutting edge surface along the full length of the bedknife. If a file is occasionally run across the front edge to remove this burr, improved cutting can be obtained.

After extended running, a ridge will eventually develop at both ends of the bedknife. These notches must be rounded off or filed flush with the cutting edge of the bedknife to ensure smooth operation.

**Note:** Over time, the chamfer (Figure 23) will need to be ground as it is only designed to last 40% of the bedknife life.

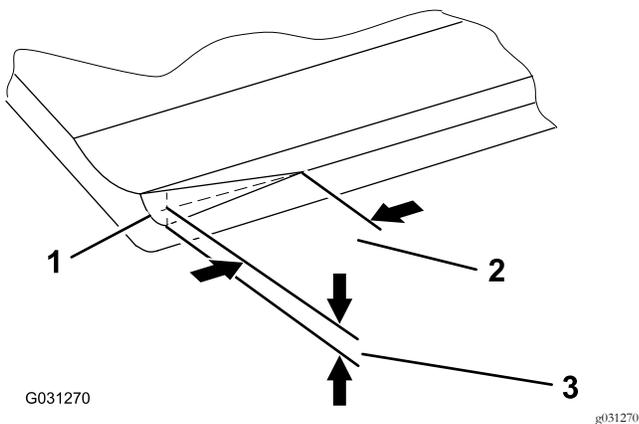

**Figure 23**

1. Lead-in chamfer on right end of bedknife
2. 6 mm (0.25 inch)
3. 1.5 mm (0.060 inch)

**Note:** Do not make the lead-in chamfer too large as it may cause turf tufting.

# Maintenance

## Lubricating the Cutting Unit

Each cutting unit has 5 grease fittings (Figure 24) that must be lubricated regularly with No. 2 lithium grease.

The lubrication points are the front roller (2), the rear roller (2), and at the reel motor spline (1).

**Note:** Lubricating the cutting units immediately after washing helps purge water out of the bearings and increases bearing life.

1. Wipe each grease fitting with a clean rag.
2. Apply grease until clean grease comes out of the roller seals and the bearing relief valve.
3. Wipe any excess grease away.

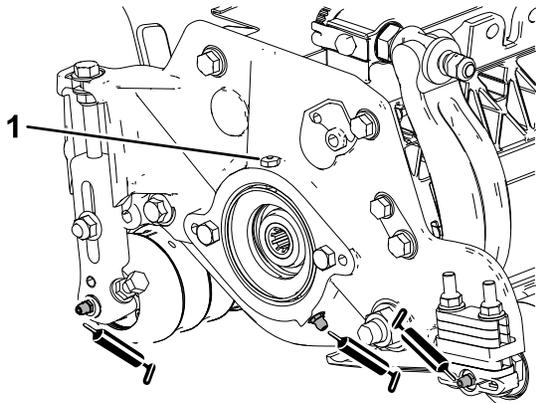
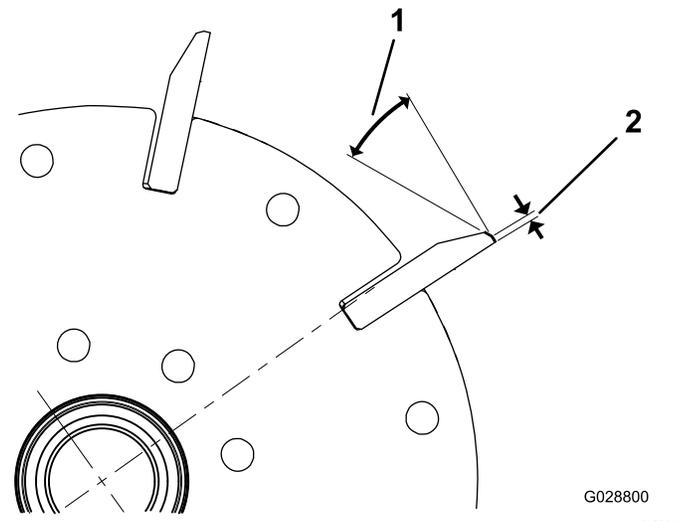

Figure 24

g191601

1. Relief valve



G028800  
g028800

Figure 25

1. 30 degrees
2. 1.3 mm (0.050 inch)

2. Spin grind the reel to achieve <math><0.025\text{ mm}</math> (0.001 inch) reel run-out.

**Note:** This causes the land width to grow slightly.

**Note:** To extend the longevity of the sharpness of the edge of the reel and the bedknife—after grinding the reel and/or the bedknife—check the reel to bedknife contact again after cutting 2 fairways, as any burrs will be removed, which may create improper reel to bedknife clearance and thus accelerate wear.

## Relief-Grinding the Reel

The new reel has a land width of 1.3 to 1.5 mm (0.050 to 0.060 inch) and a 30 degree relief grind.

When the land width gets larger than 3 mm (0.120 inch) wide, do the following:

1. Apply a 30 degree relief grind on all reel blades until the land width is 1.3 mm (0.050 inch) wide (Figure 25).

# Servicing the Bedknife

The bedknife service limits are listed in the following chart.

**Important:** Operating the cutting unit with the bedknife below the service limit may result in poor after-cut appearance and reduce the structural integrity of the bedknife for impacts.

Bedknife Service Limit Chart				
Bedknife	Part No.	Bedknife Lip Height	Service Limit*	Grind Angles Top/Front Angles
Low HOC (Optional)	120-1641 (27 inch) 120-1642 (32 inch)	5.6 mm (0.220 inch)	4.8 mm (0.190 inch)	10/5 degrees
EdgeMax® (Optional)	112-8910 (27 inch) 112-8956 (32 inch)	6.9 mm (0.270 inch)	4.8 mm (0.190 inch)	10/5 degrees
Standard (Production)	114-9388 (27 inch) 114-9389 (32 inch)	6.9 mm (0.270 inch)	4.8 mm (0.190 inch)	10/5 degrees
Heavy Duty (Optional)	114-9390 (27 inch) 114-9391 (32 inch)	9.3 mm (0.370 inch)	4.8 mm (0.190 inch)	10/5 degrees

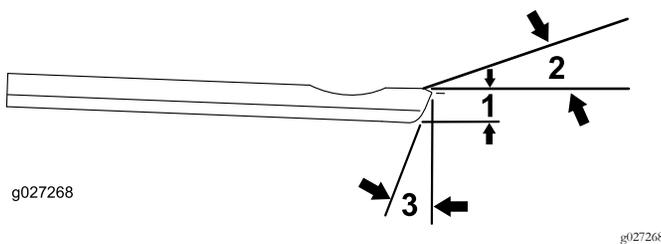
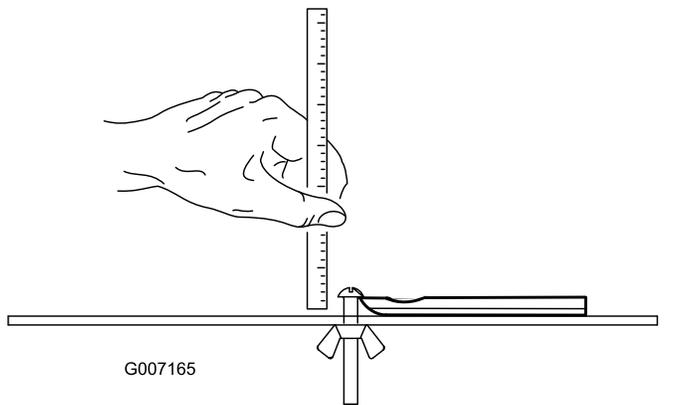

**Figure 26**

### Recommended Top and Front Bedknife Grind Angles

1. Bedknife service limit\*
2. Top grind angle
3. Front grind angle

**Note:** All bedknife service limit measurements relate to the bottom of the bedknife (Figure 27).



**Figure 27**

## Checking the Top Grind Angle

The angle that you use to grind your bedknives is very important.

Use the angle indicator (Toro Part No. 131-6828) and the angle-indicator mount (Toro Part No. 131-6829) to check the angle that your grinder produces and then correct for any grinder inaccuracy.

1. Place the angle indicator on the bottom side of the bedknife as shown in Figure 28.

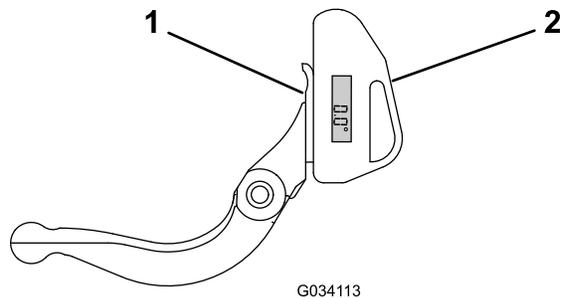
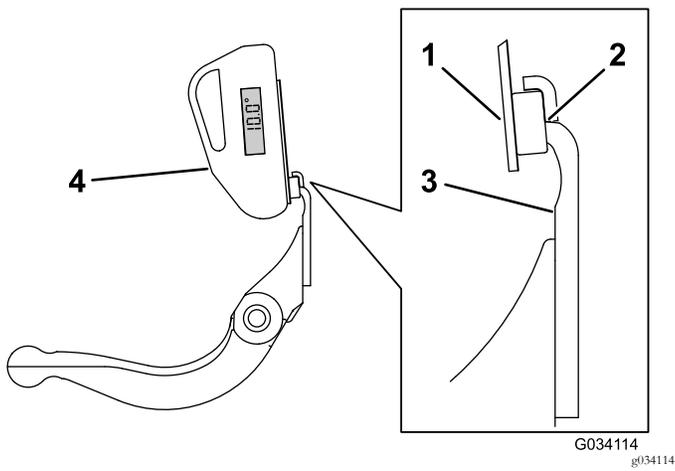

**Figure 28**

1. Bedknife (vertical)
2. Angle indicator

2. Press the Alt Zero button on the angle indicator.
3. Place the angle-indicator mount on the edge of the bedknife so that the edge of the magnet is mated with the edge of the bedknife (Figure 29).

**Note:** The digital display should be visible from the same side during this step as it was in step 1.



**Figure 29**

- |   |                    |
|---|--------------------|
| 1. Angle-indicator mount                                  | 3. Bedknife        |
| 2. Edge of the magnet mated with the edge of the bedknife | 4. Angle indicator |

- Place the angle indicator on the mount as shown in [Figure 29](#).

**Note:** This is the angle that your grinder produces; it should be within 2 degrees of the recommended top grind angle.

## Servicing the Bedbar

### Removing the Bedbar

- Turn the bedbar-adjuster screws counterclockwise to back the bedknife away from the reel ([Figure 30](#)).

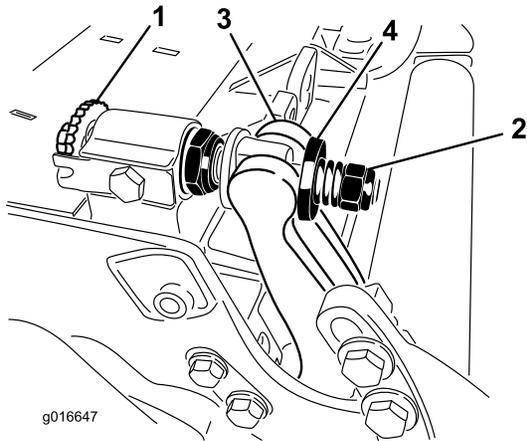

**Figure 30**

- |                           |           |
|---------------------------|-----------|
| 1. Bedbar-adjusting screw | 3. Bedbar |
| 2. Spring-tension nut     | 4. Washer |

- Back out the spring-tension nut until the washer is no longer tensioned against the bedbar ([Figure 30](#)).
- On each side of the machine, loosen the locknut securing the bedbar bolt ([Figure 31](#)).

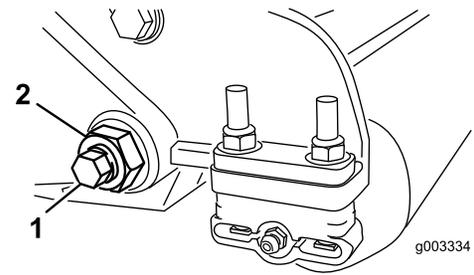
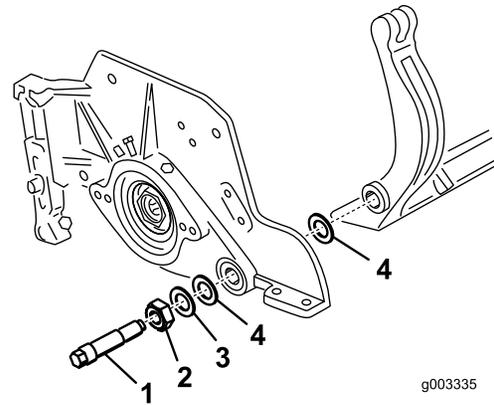

**Figure 31**

- |                |             |
|----------------|-------------|
| 1. Bedbar bolt | 2. Lock nut |
|----------------|-------------|

- Remove each bedbar bolt, allowing the bedbar to be pulled downward and removed from machine bolt ([Figure 31](#)).

**Note:** Account for 2 nylon washers and 1 stamped steel washer on each end of the bedbar ([Figure 32](#)).



**Figure 32**

- |                |                 |
|----------------|-----------------|
| 1. Bedbar bolt | 3. Steel washer |
| 2. Nut         | 4. Nylon washer |

### Assembling the Bedbar

- Install the bedbar, positioning the mounting ears between the washer and the bedbar adjuster.
- Secure the bedbar to each side plate with the bedbar bolts (nuts on bolts) and 6 washers.

**Note:** Position a nylon washer on each side of the side-plate boss. Place a steel washer outside each of the nylon washers ([Figure 32](#)).

- Torque the bedbar bolts to 37 to 45 N·m (27 to 33 ft-lb).

**Note:** Tighten the locknuts until the outside steel washer stops rotating and end play is removed, but do not overtighten or deflect the side plates. The washers on the inside may have a gap.

- Tighten the spring-tension nut until the spring is collapsed, then back off 1/2 turn ([Figure 33](#)).

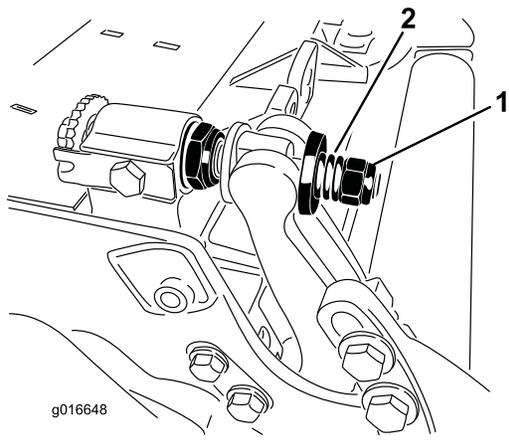

**Figure 33**

- 1. Spring-tension nut
  - 2. Spring
-

# Servicing the HD Dual Point Adjusters (DPA)

1. Remove all parts (refer to the *Installation Instructions* for the HD DPA Kit (Model No. 120-7230) and to [Figure 34](#)).
2. Apply anti-seize compound to the inside of the bushing area on the carrier frame of the cutting unit ([Figure 34](#)).

3. Align the keys on flange bushings to the slots in the frame and install the bushings ([Figure 34](#)).
4. Install a wave washer onto the adjuster shaft and slide the adjuster shaft into the flange bushings in the frame of the cutting unit ([Figure 34](#)).
5. Secure the adjuster shaft with a flat washer and locknut ([Figure 34](#)). Torque the locknut to 20 to 27 N·m (15 to 20 ft-lb).

**Note:** The bedbar adjuster shaft has left-hand threads.

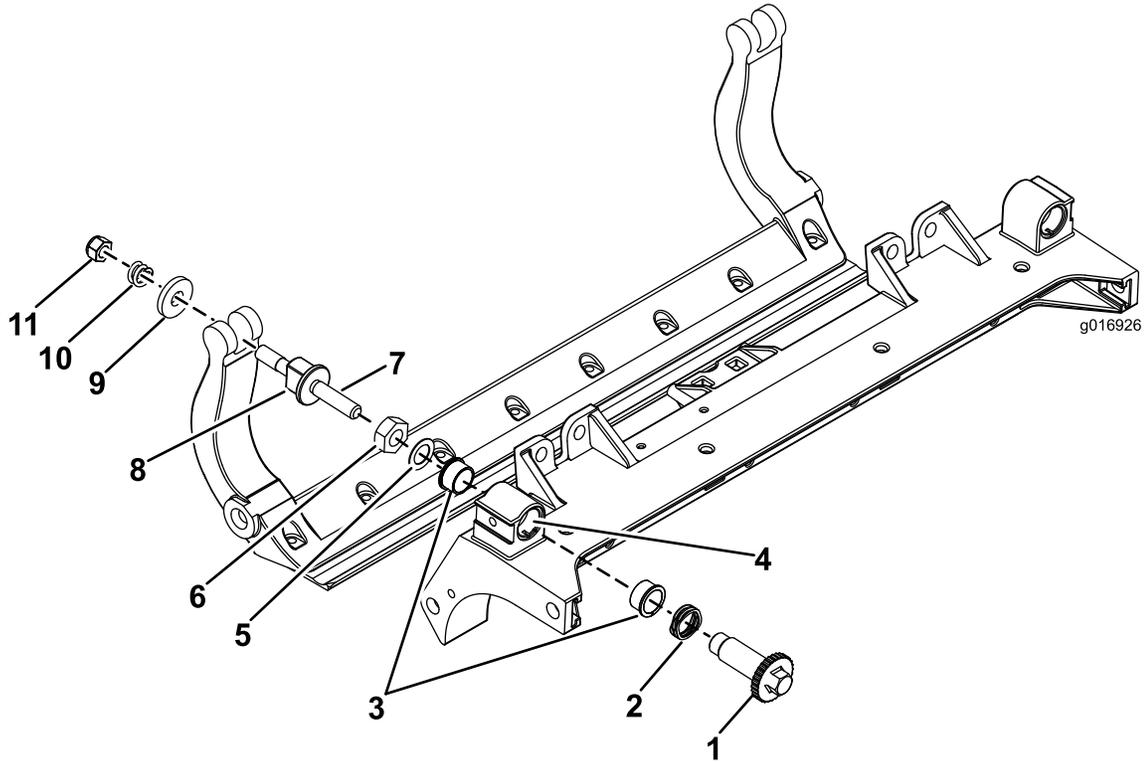

**Figure 34**

- |                   |                                    |                                    |                        |
|-------------------|------------------------------------|------------------------------------|------------------------|
| 1. Shaft adjuster | 4. Apply anti-seize compound here. | 7. Apply anti-seize compound here. | 10. Compression spring |
| 2. Wave washer    | 5. Flat washer                     | 8. Bedbar-adjuster screw           | 11. Spring-tension nut |
| 3. Flange bushing | 6. Locknut                         | 9. Hardened washer                 |                        |

6. Apply anti-seize compound to the threads of the bedbar-adjuster screw that fit into the adjuster shaft.
7. Thread the bedbar-adjuster screw into the adjuster shaft.
8. Loosely install the hardened washer, spring, and spring-tension nut onto the adjuster screw.
9. Install the bedbar, positioning the mounting ears between the washer and the bedbar adjuster.
10. Secure the bedbar to each side plate with the bedbar bolts (nuts on bolts) and 6 washers.

**Note:** Position a nylon washer on each side of the side plate boss.

Place a steel washer outside each of the nylon washers ([Figure 34](#)).

Torque the bedbar bolts to 37 to 45 N·m (27 to 33 ft-lb). Tighten the locknuts until the outside steel washer stops rotating and end play is removed, but do not overtighten or deflect the side plates. The washers on the inside may have a gap.

11. Tighten the nut on each bedbar-adjuster assembly until the compression spring is fully compressed, then loosen the nut 1/2 turn ([Figure 34](#)).
12. Repeat the procedure on the other end of the cutting unit.
13. Adjust the bedknife to the reel.

# Servicing the Roller

The Roller Rebuild Kit (Part No. 114-5430) and the Roller Rebuild Tool Kit (Part No. 115-0803) (Figure 35) are available for servicing the roller. The Roller Rebuild Kit includes all the bearings, bearing

nuts, inner seals, and outer seals to rebuild a roller. The Roller Rebuild Tool Kit includes all the tools and the installation instructions required to rebuild a roller with the roller rebuild kit. Refer to your parts catalog or contact your Authorized Toro Distributor for assistance.

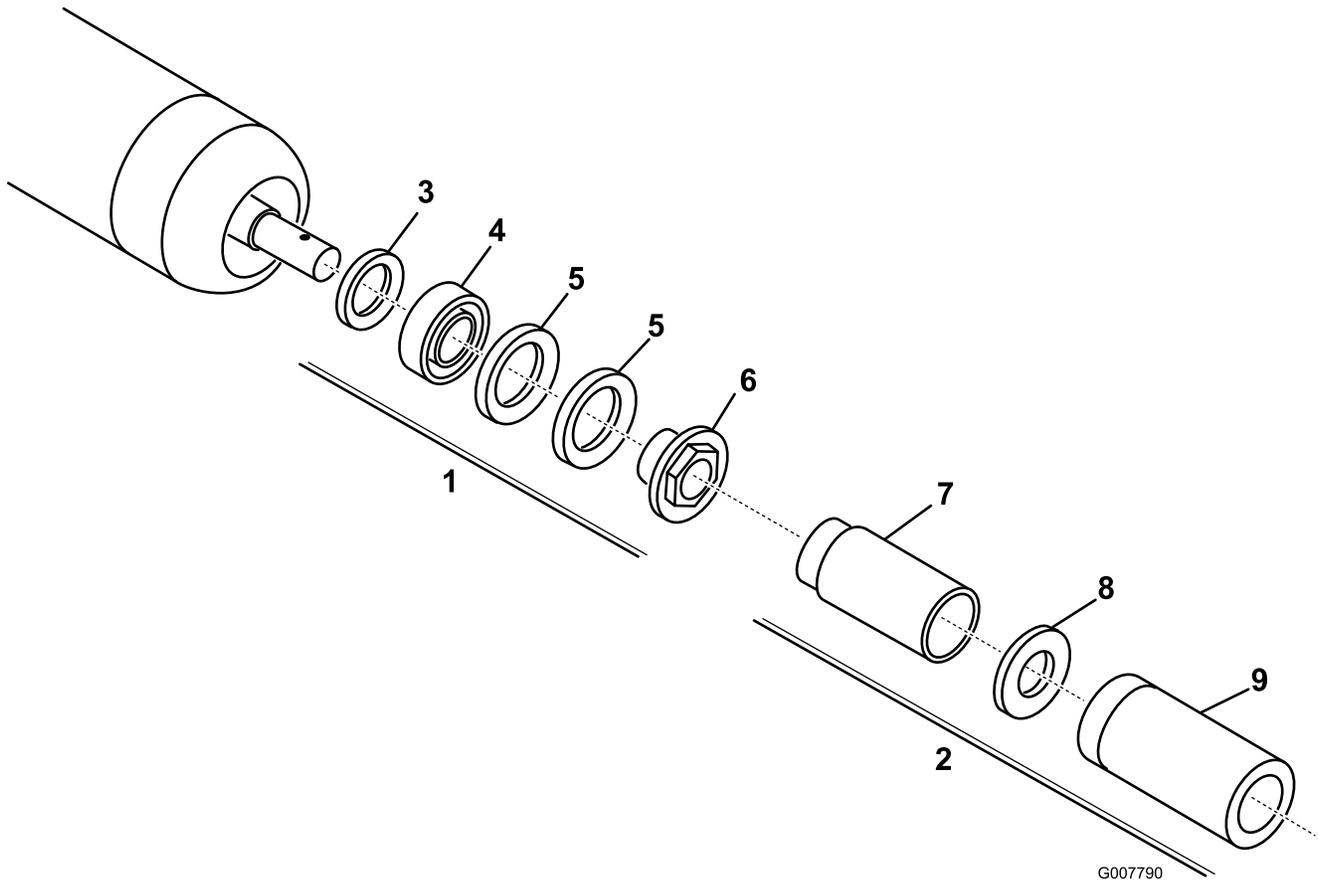

**Figure 35**

1. Roller Rebuild Kit (Part No. 114-5430)
2. Roller Rebuild Tool kit (Part No. 115-0803)
3. Inner seal
4. Bearing
5. Outer seal
6. Bearing nut
7. Inner-seal tool
8. Washer
9. Bearing/outer-seal tool

**Notes:**

# Declaration of Incorporation

The Toro Company, 8111 Lyndale Ave. South, Bloomington, MN, USA declares that the following unit(s) conform(s) to the directives listed, when installed in accordance with the accompanying instructions onto certain Toro models as indicated on the relevant Declarations of Conformity.

Model No.	Serial No.	Product Description	Invoice Description	General Description	Directive
03721	400000000 and Up	27-inch 8-Blade Edge Series Cutting Unit, Reelmaster 7000-D Traction Unit	RM7000 27IN 8-BLADE ES (RR) DPA CU	Cutting Unit	2000/14/EC 2006/42/EC
03722	400000000 and Up	27-inch Edge Series 11-Blade Cutting Unit, Reelmaster 7000-D Traction Unit	RM7000 27IN 11-BLADE ES (RR) DPA CU	Cutting Unit	2000/14/EC 2006/42/EC
03727	400000000 and Up	32-inch 8-Blade Edge Series Cutting Unit, Reelmaster 7000-D Traction Unit	RM7000 32IN 8-BLADE ES (RR) DPA CU	Cutting Unit	2000/14/EC 2006/42/EC

Relevant technical documentation has been compiled as required per Part B of Annex VII of 2006/42/EC.

We will undertake to transmit, in response to requests by national authorities, relevant information on this partly completed machinery. The method of transmission shall be electronic transmittal.

This machinery shall not be put into service until incorporated into approved Toro models as indicated on the associated Declaration of Conformity and in accordance with all instructions, whereby it can be declared in conformity with all relevant Directives.

Certified:



David Klis  
Sr. Engineering Manager  
8111 Lyndale Ave. South  
Bloomington, MN 55420, USA  
October 20, 2016

EU Technical Contact:

Marc Vermeiren  
Toro Europe NV  
B-2260 Oevel-Westerloo  
Belgium

Tel. 0032 14 562960  
Fax 0032 14 581911

## **European Privacy Notice**

### **The Information Toro Collects**

Toro Warranty Company (Toro) respects your privacy. In order to process your warranty claim and contact you in the event of a product recall, we ask you to share certain personal information with us, either directly or through your local Toro company or dealer.

The Toro warranty system is hosted on servers located within the United States where privacy law may not provide the same protection as applies in your country.

**BY SHARING YOUR PERSONAL INFORMATION WITH US, YOU ARE CONSENTING TO THE PROCESSING OF YOUR PERSONAL INFORMATION AS DESCRIBED IN THIS PRIVACY NOTICE.**

### **The Way Toro Uses Information**

Toro may use your personal information to process warranty claims, to contact you in the event of a product recall and for any other purpose which we tell you about. Toro may share your information with Toro's affiliates, dealers or other business partners in connection with any of these activities. We will not sell your personal information to any other company. We reserve the right to disclose personal information in order to comply with applicable laws and with requests by the appropriate authorities, to operate our systems properly or for our own protection or that of other users.

### **Retention of your Personal Information**

We will keep your personal information as long as we need it for the purposes for which it was originally collected or for other legitimate purposes (such as regulatory compliance), or as required by applicable law.

### **Toro's Commitment to Security of Your Personal Information**

We take reasonable precautions in order to protect the security of your personal information. We also take steps to maintain the accuracy and current status of personal information.

### **Access and Correction of your Personal Information**

If you would like to review or correct your personal information, please contact us by email at [legal@toro.com](mailto:legal@toro.com).

## **Australian Consumer Law**

Australian customers will find details relating to the Australian Consumer Law either inside the box or at your local Toro Dealer.



# The Toro Warranty

## A Two-Year Limited Warranty

### Conditions and Products Covered

The Toro Company and its affiliate, Toro Warranty Company, pursuant to an agreement between them, jointly warrant your Toro Commercial product ("Product") to be free from defects in materials or workmanship for two years or 1500 operational hours\*, whichever occurs first. This warranty is applicable to all products with the exception of Aerators (refer to separate warranty statements for these products). Where a warrantable condition exists, we will repair the Product at no cost to you including diagnostics, labor, parts, and transportation. This warranty begins on the date the Product is delivered to the original retail purchaser.

\* Product equipped with an hour meter.

### Instructions for Obtaining Warranty Service

You are responsible for notifying the Commercial Products Distributor or Authorized Commercial Products Dealer from whom you purchased the Product as soon as you believe a warrantable condition exists. If you need help locating a Commercial Products Distributor or Authorized Dealer, or if you have questions regarding your warranty rights or responsibilities, you may contact us at:

Toro Commercial Products Service Department  
Toro Warranty Company  
8111 Lyndale Avenue South  
Bloomington, MN 55420-1196  
952-888-8801 or 800-952-2740  
E-mail: commercial.warranty@toro.com

### Owner Responsibilities

As the Product owner, you are responsible for required maintenance and adjustments stated in your *Operator's Manual*. Failure to perform required maintenance and adjustments can be grounds for disallowing a warranty claim.

### Items and Conditions Not Covered

Not all product failures or malfunctions that occur during the warranty period are defects in materials or workmanship. This warranty does not cover the following:

- Product failures which result from the use of non-Toro replacement parts, or from installation and use of add-on, or modified non-Toro branded accessories and products. A separate warranty may be provided by the manufacturer of these items.
- Product failures which result from failure to perform recommended maintenance and/or adjustments. Failure to properly maintain your Toro product per the Recommended Maintenance listed in the *Operator's Manual* can result in claims for warranty being denied.
- Product failures which result from operating the Product in an abusive, negligent, or reckless manner.
- Parts subject to consumption through use unless found to be defective. Examples of parts which are consumed, or used up, during normal Product operation include, but are not limited to, brake pads and linings, clutch linings, blades, reels, rollers and bearings (sealed or greasable), bed knives, spark plugs, castor wheels and bearings, tires, filters, belts, and certain sprayer components such as diaphragms, nozzles, and check valves, etc.
- Failures caused by outside influence. Conditions considered to be outside influence include, but are not limited to, weather, storage practices, contamination, use of unapproved fuels, coolants, lubricants, additives, fertilizers, water, or chemicals, etc.
- Failure or performance issues due to the use of fuels (e.g. gasoline, diesel, or biodiesel) that do not conform to their respective industry standards.

### Countries Other than the United States or Canada

Customers who have purchased Toro products exported from the United States or Canada should contact their Toro Distributor (Dealer) to obtain guarantee policies for your country, province, or state. If for any reason you are dissatisfied with your Distributor's service or have difficulty obtaining guarantee information, contact the Toro importer.

- Normal noise, vibration, wear and tear, and deterioration.
- Normal "wear and tear" includes, but is not limited to, damage to seats due to wear or abrasion, worn painted surfaces, scratched decals or windows, etc.

### Parts

Parts scheduled for replacement as required maintenance are warranted for the period of time up to the scheduled replacement time for that part. Parts replaced under this warranty are covered for the duration of the original product warranty and become the property of Toro. Toro will make the final decision whether to repair any existing part or assembly or replace it. Toro may use remanufactured parts for warranty repairs.

### Deep Cycle and Lithium-Ion Battery Warranty:

Deep cycle and Lithium-Ion batteries have a specified total number of kilowatt-hours they can deliver during their lifetime. Operating, recharging, and maintenance techniques can extend or reduce total battery life. As the batteries in this product are consumed, the amount of useful work between charging intervals will slowly decrease until the battery is completely worn out. Replacement of worn out batteries, due to normal consumption, is the responsibility of the product owner. Battery replacement may be required during the normal product warranty period at owner's expense. Note: (Lithium-Ion battery only): A Lithium-Ion battery has a part only prorated warranty beginning year 3 through year 5 based on the time in service and kilowatt hours used. Refer to the *Operator's Manual* for additional information.

### Maintenance is at Owner's Expense

Engine tune-up, lubrication, cleaning and polishing, replacement of filters, coolant, and completing recommended maintenance are some of the normal services Toro products require that are at the owner's expense.

### General Conditions

Repair by an Authorized Toro Distributor or Dealer is your sole remedy under this warranty.

**Neither The Toro Company nor Toro Warranty Company is liable for indirect, incidental or consequential damages in connection with the use of the Toro Products covered by this warranty, including any cost or expense of providing substitute equipment or service during reasonable periods of malfunction or non-use pending completion of repairs under this warranty. Except for the Emissions warranty referenced below, if applicable, there is no other express warranty. All implied warranties of merchantability and fitness for use are limited to the duration of this express warranty.**

Some states do not allow exclusions of incidental or consequential damages, or limitations on how long an implied warranty lasts, so the above exclusions and limitations may not apply to you. This warranty gives you specific legal rights, and you may also have other rights which vary from state to state.

### Note regarding engine warranty:

The Emissions Control System on your Product may be covered by a separate warranty meeting requirements established by the U.S. Environmental Protection Agency (EPA) and/or the California Air Resources Board (CARB). The hour limitations set forth above do not apply to the Emissions Control System Warranty. Refer to the Engine Emission Control Warranty Statement supplied with your product or contained in the engine manufacturer's documentation for details.