



MODEL NO. 04480—60001 & UP MODEL NO. 04481—60001 & UP	OPERATOR'S MANUAL
8- & 11-BLADE CUTTING UNITS (For Greensmaster® 3200)	

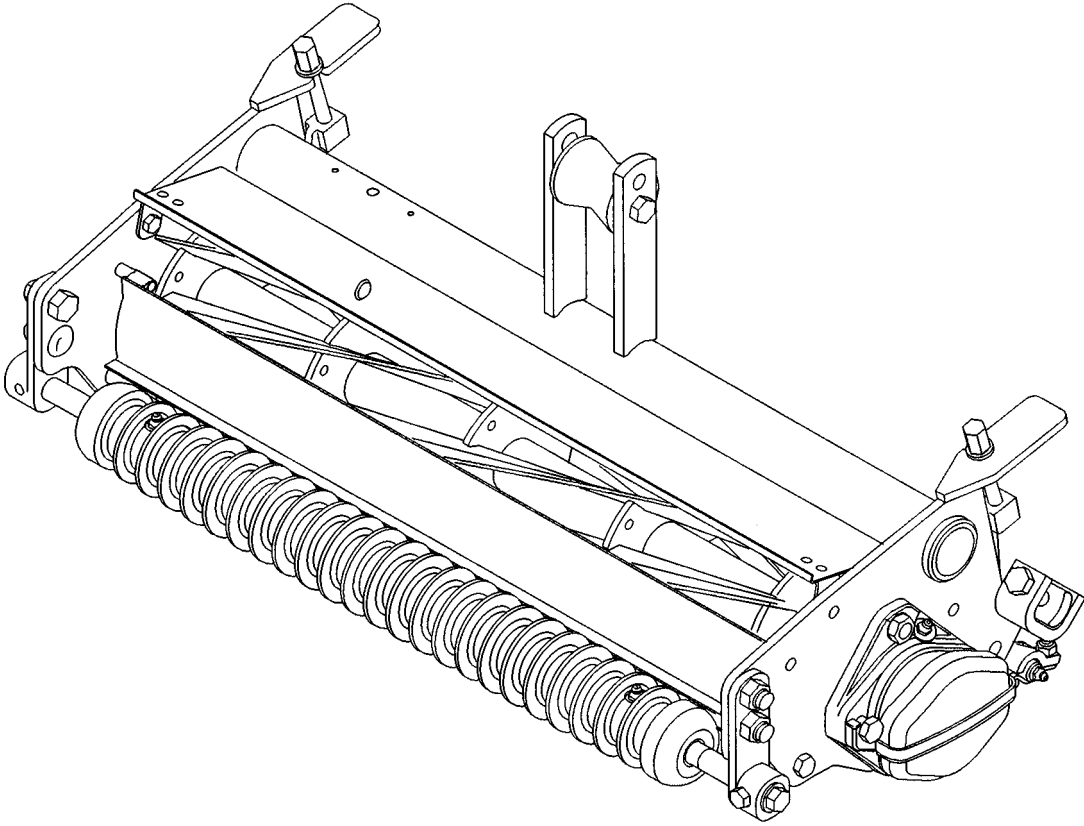

Table of Contents

	Page		
SPECIFICATIONS	2	Cutting Unit Daily Adjustments	5
ADJUSTING THE CUTTING UNIT	3	LUBRICATION	5
Adjusting The bedknife To The Reel	4	Greasing Bearings And Bushings	5
Leveling Front Roller To The Reel	4	BACKLAPPING THE CUTTING UNIT	6
Adjusting Height-of-Cut	5		

Specifications

Height-of-Cut: The cutting height is adjusted on rear roller by two vertical screws and held by two locking capscrews. Bench height-of-cut range is 2.4mm to 19mm. Effective height of cut will vary depending on turf conditions and bedknife.

Reel Construction: Reels are 13cm in diameter, 53.3 cm in length. High-carbon steel blades are welded to 5 stamped-steel spiders. and heat treated to RC 42-48 hardness. The reel is ground for diameter, concentricity. and back grind.

Reel Bearings: Two double-row ball bearings, 30 mm internal diameter., press fit onto the reel shaft. The inverted seal is pressed onto the reel shaft. Bearing side load is maintained by a 3 1/2 turn wave washer, with no adjusting nut.

Reel Drive: The reel shaft is a 1.375 inch diameter tube with drive inserts permanently pressed in both ends. A replaceable floating coupler with an internal eight-tooth spline is factory installed on the right end, and held in place by a snap ring. The floating coupler may be moved to the other end when the cutting unit is used on the tractor's front right position.

Frame Construction: A single top tube is welded to two sideplates. A bolt-in cross rod acts to set the front frame width and stiffen the assembly. The lift straps have a replaceable roller that may be moved to change transport height.

Bedknife: Replaceable, 13-screw, single-edged, high carbon steel bedknife austempered to RC 48-55, fastened to a machined cast iron bedbar. Tournament bedknife is standard.

Bedknife Adjustment: Two opposing screws on

each end of the bed bar are used to level and regulate the bedknife-to-reel contact.

Front Roller: The standard front roller is a 6.4 cm diameter Weihle. The right bracket has an eccentric shoulder bolt to provide leveling. A second eccentric may be added to the left bracket for increased leveling range. The roller has a through shaft with greaseable ball bearings.

Rear Roller: The standard rear roller is a 5.2 cm diameter smooth roller. It has a through shaft with greaseable ball bearings.

Front Shield: A snap-in shield covers the lower front of the reel. The shield helps improve grass throwing into the basket and prevents the basket sealing flap from being damaged by the reel.

Counterbalance Weight: The left end of the cutting unit has a weight with a spin flange like the reel motors for easy installation. The weight seals the bearing area and balances the reel motor's weight during cutting.

Options:

Micro-Cut Bedknife	Part No. 93-4262
Lo-Cut Bedknife	Part No. 63-8470
High-Cut Bedknife	Part No. 92-2510
Fairway Bedknife	Part No. 63-8610

Specifications and design are subject to change without notice.

IMPORTANT: Read this Operator's Manual thoroughly before operating the cutting unit. Failure to do so may result in damage to the cutting unit.

Adjusting the Cutting Unit

Note: Left and right sides of the cutting unit refer to normal operating position.

After the cutting unit is unboxed, use the following procedures to assure the cutting unit is adjusted properly.

1. Check each end of the reel for grease. Grease should be visibly evident in the reel bearings.
2. Insure that all nuts and bolts are securely fastened.
3. Position the lift roller to match suspension.
 - Upper position for old style suspensions
 - Lower position for new suspensions (On GR 3200)
4. Install the pull rod studs and lockwashers (included in loose parts), to the front roller shaft ends, if using older types of suspension.
5. Check to make sure the bedknife and reel are parallel. Refer to *Adjusting The Bedknife To The Reel*.

ADJUSTING THE BEDKNIFE TO THE REEL (Fig. 1 & 2)

1. Remove the cutting units from the traction unit and position them on a level work surface.
2. Adjust the bedknife to the reel by first, loosening the bottom adjusting screw on each side of the cutting unit, then tightening the top adjusting screw on each side of the cutting unit. This adjustment will position the bedknife closer to the reel blades.

IMPORTANT: Use only a M13 wrench, 8 to 15 cm length when adjusting the bedknife screws. A longer wrench will provide too much leverage and may distort the mounting plate for the adjustment screws.

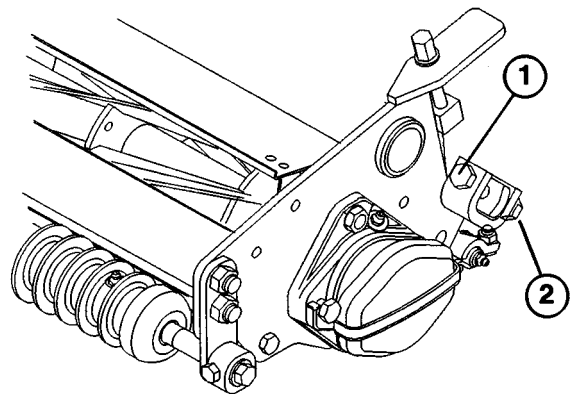

Figure 1

1. Top adjusting screw
2. Bottom adjusting screw

3. After adjusting the bedknife to the reel, make sure that both the top and bottom adjusting screws are secured on both ends of the cutting unit.

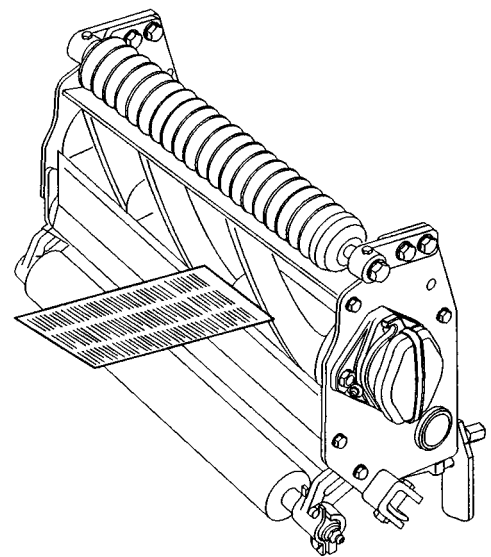

Figure 2

4. After the adjustment, check to see if the reel can pinch paper when inserted from the front and cut paper when inserted at a right angle. It should be possible to cut paper with minimum contact between the bedknife and the reel blades. Should excessive reel drag be evident it will be necessary to either back lap or re-grind the cutting unit to achieve the sharp edge needed for precision cutting. Refer to the Toro Reel Sharpening Manual, Form No. 80-300PT.

LEVELING THE FRONT ROLLER TO THE REEL (Fig. 3)

1. Position the cutting unit on a flat, level surface.
2. Position a 6 mm or thicker plate under the reel blades and against the front face of the bedknife.

Note: Be sure the plate covers the full length of the reel blades and three blades contact the plate.

3. Loosen the locknuts retaining the right-front roller bracket.

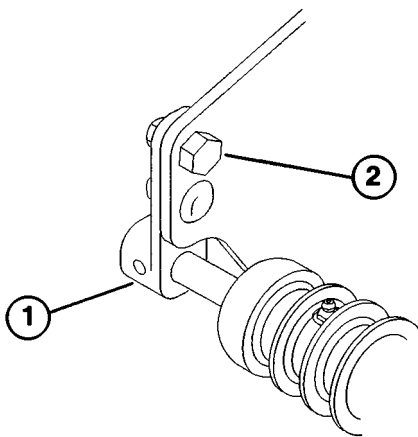

Figure 3

1. Right front roller bracket
2. Upper right roller mounting bolt

4. While holding the reel securely on the plate and maintaining pressure on the front roller, rotate the upper right roller mounting bolt. This mounting bolt has an offset, which when rotated, acts as an eccentric (cam) to raise or lower the roller. On the bolt head there is an internal diameter dot which denotes the offset of the bolt. The dot indicates in which direction the right end of the roller moves when the bolt is turned.

Note: Insure both front roller brackets are in the same hole.

5. To verify if the roller is level, try inserting a piece of paper under each end of the roller.
6. When the roller is level, tighten the nuts securely.

Note: If additional adjustment is required, replace one

screw on L.H. bracket with another eccentric bolt, part no. 93-2573.

Note: There are two positions for the front roller brackets.

For most mowing applications, the lower position is typically used.

The upper position is more aggressive and may be used in a limited height-of-cut range (.140-.250") if conditions warrant.

ADJUSTING THE HEIGHT OF CUT (Fig. 4)

1. Verify that the front roller is level and the bed-knife-to-reel contact is correct.

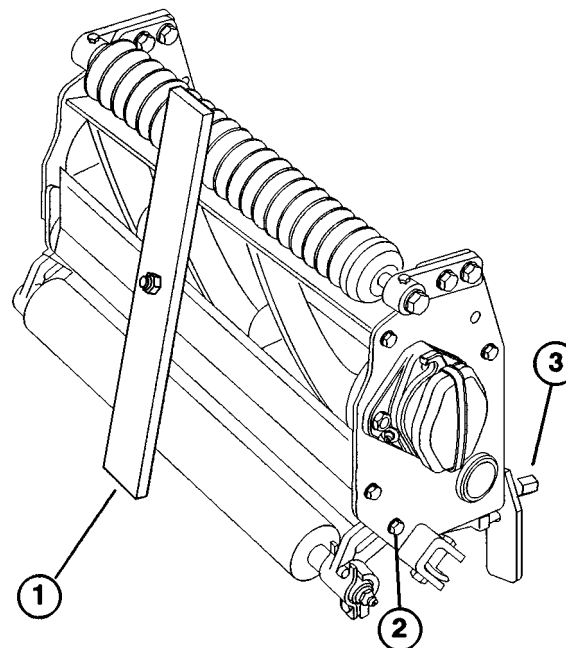

Figure 4

1. Gauge bar
2. Roller bracket capscrew
3. Height-of-cut knob

2. Turn the cutting unit over (90°) and rest it on the rear roller and top rear tabs. Loosen the locknuts on the capscrews that retain the rear roller brackets.
3. On a gauge bar (Part no. 13-8199), set the head the screw to the desired height of cut. This mea-

surement is from the bar face to the underside of the screw head.

- Place the bar across the front and rear rollers and adjust the height-of-cut knob until the underside of the screw head engages the bedknife cutting edge.

IMPORTANT: Repeat the procedure on each end of the bedknife and tighten locknuts that retain rear roller brackets on each end.

CUTTING UNIT DAILY ADJUSTMENTS

Prior to each day's mowing, or as required, each cutting unit must be checked to verify proper bedknife-to-reel contact. This must be performed even though quality of cut is acceptable.

IMPORTANT: Light contact is preferred at all times. If light contact is not maintained, bedknife /

Lubrication

Lithium Base Grease.

- The grease fitting locations and quantities are: Reel bearings (2) and front and rear rollers (2 ea.) (Fig.)

IMPORTANT: Lubricating the cutting units immediately after washing helps purge water from the bearings and increases bearing life.

- Wipe each grease fitting with a clean cloth.
- Apply grease until pressure is felt against the handle.

IMPORTANT: Do not apply too much pressure or grease seals will be permanently damaged.

- Wipe away excess grease.

reel edges will not sufficiently self-sharpen and dull cutting edges will result after a period of operation. If excessive contact is maintained, bedknife/reel wear will accelerate, uneven wear can result, and quality of cut may be adversely affected.

Note: As the reel blades continue to run against the bedknife, a slight burr will appear on the front cutting edge surface the full length of the bedknife. Running a file across the front edge to remove this burr will improve cutting.

After extended running, a ridge will eventually develop at both ends of the bedknife. These notches must be rounded off or filed flush with the cutting edge of the bedknife to assure smooth operation.

GREASING BEARINGS AND BUSHINGS

Each cutting unit has (6) grease fittings that must be lubricated regularly with No. 2 General Purpose

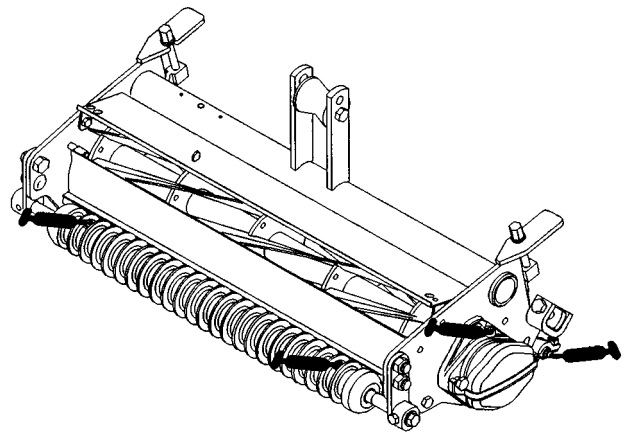

Figure 5

Backlapping the Cutting Units



CAUTION

Be careful when lapping the reel because contact with the reel or other moving parts can result in personal injury.

1. Position the machine on a clean, level surface, lower the cutting units, stop the engine, engage the parking brake and remove the key from the ignition switch.
2. Remove the reel motors from the cutting units and disconnect and remove the cutting units from the lift arms.

3. Connect the backlapping machine to the cutting unit by inserting a piece of 9mm square stock into the splined coupling at the right end of the cutting unit.

Note: Additional instructions and procedures on backlapping are available in the TORO Sharpening Reel & Rotary Mowers Manual Form No. 80-300PT.

Note: For a better cutting edge, run a file across the front face of the bedknife after completing the lapping operation. This will remove any burrs or rough edges that may have built up on the cutting edge.

The Toro Commercial Products Two-Year Limited Warranty

The Toro Company warrants your 1996 or newer Toro Commercial Product ("Product") purchased after January 1, 1997, to be free from defects in materials or workmanship for the period of time listed below. Where a warrantable condition exists, Toro will repair the Product at no cost to you including diagnosis, labor, parts, and transportation. This warranty begins on the date the Product is delivered to the original retail purchaser.

Warranty Duration: Two years or 1500 operational hours*, whichever occurs first.

***Product equipped with hour meter**

Owner Responsibilities:

As the Product owner, you are responsible for required maintenance and adjustments stated in your Owner's Manual. Failure to perform required maintenance and adjustments can be grounds for disallowing a warranty claim.

Instructions for Obtaining Warranty Service:

You are responsible for notifying the Commercial Products Distributor or Authorized Commercial Products Dealer from whom you purchased the Product as soon as you believe a warrantable condition exists.

If you need help locating a Commercial Products Distributor or Authorized Dealer, or if you have questions regarding your warranty rights or responsibilities, you may contact us at:

Toro Commercial Products Service Department
8111 Lyndale Avenue South
Minneapolis, MN, 55420-1196
Telephone: (612) 888-8801
Facsimile: (612) 887-8258
E-Mail: Commercial.Service@Toro.Com

Maintenance Parts:

Parts scheduled for replacement as required maintenance ("Maintenance Parts"), are warranted for the period of time up to the scheduled replacement time for that part.

Items/Conditions Not Covered:

Not all product failures or malfunctions that occur during the warranty period are defects in materials or workmanship. The items/conditions listed below are not covered by this warranty:

- Product failures which result from the use of non-Toro replacement parts, or from installation and use of add-on, modified, or unapproved accessories are not covered.
- Product failures which result from failure to perform required maintenance and/or adjustments are not covered.

- Product failures that result from operating the Product in an abusive, negligent or reckless manner are not covered.
- This warranty does not apply to parts subject to consumption through use unless found to be defective. Examples of parts which are consumed, or used up, during normal Product operation include, but are not limited to, blades, reels, bedknives, tines, spark plugs, castor wheels, tires, filters, belts, etc.
- This warranty does not apply to failures caused by outside influence. Items considered to be outside influence include, but are not limited to, weather, storage practices, contamination, use of unapproved coolants, lubricants, additives, or chemicals, etc.
- This warranty does not apply to normal "wear and tear" items. Normal "Wear and Tear" includes, but is not limited to, damage to seats due to wear or abrasion, worn painted surfaces, scratched decals or windows, etc.

Other Legal Disclaimers:

The above remedy of product defects through repair by an authorized distributor or dealer is the purchaser's sole remedy for any defect. This warranty gives you specific legal rights, and you may also have other rights which vary from state to state.

Except for the Emissions warranty referenced below, if applicable, there is no other express warranty. All implied warranties of merchantability and fitness for use are limited to the duration of the express warranty.

Some states do not allow limitations on how long an implied warranty lasts, so the above limitation may not apply to you.

The Toro Company is not liable for indirect, incidental or consequential damages in connection with the use of the Product, including any cost or expense of providing substitute Product or service during periods of malfunction or non-use.

Some states do not allow the exclusion of incidental or consequential damages, so the above exclusion may not apply to you.

