



Count on it.

Parts Catalog

**Z Master[®] Commercial 3000
Series Riding Mower**

**with 60in TURBO FORCE[®] Side Discharge
Mower**

Model No. 74996—Serial No. 316000001 and Up



Ordering Replacement Parts

To order replacement parts, please supply the part number, the quantity, and the description of each part desired.

Understanding Reference Numbers

Each identified part in an illustration has a reference number. The reference number for a part also appears in the parts list, along with other information about the part.

This catalog uses two special reference number formats, one to indicate parts in a service assembly and another to indicate the quantity of a given part in an illustration.

Service Assembly Reference Numbers

Parts in service assemblies have reference numbers in the form a:b. The a represents the reference number of the entire service assembly and the b represents a sequential number unique to each part within the service assembly.

For example, a wheel assembly might be identified by reference number 6, the tire by 6:1, the valve by 6:2, and the wheel by 6:3. When you order the assembly identified by reference number 6, you receive all parts identified by reference numbers 6:1, 6:2, and 6:3. However, you may also order any part individually. Reference numbers of this type appear in illustration and in parts lists.

Reference Numbers Indicating Quantity

In an illustration, if a reference number indicates more than one part, the reference number has the form nX y. The n represents the quantity of the part, the X is the multiplication symbol, and the y represents the reference number.

For example, in an illustration, the reference number 2X 37 means that two of the parts identified by reference number 37 are indicated.

List of Abbreviations

AR: as required

ASM: assembly

BBC: blade brake control

BHTF: button head thread forming

CARR: carriage

CCW: counter clockwise

CW: clockwise

DEG: degrees

DPA: Dual Point Adjustment

ECM: electronic control module

EXT: external

FH: flat head

GA: gauge

HD: heavy-duty

HF: hex flange

HH: hex head

HHF: hex head flange

HHFTF: hex head flange thread forming

HJ: hex jam

HLH: hex lag head

HOC: height-of-cut

HP: high pressure

HSBH: hex socket button head

HSFH: hex socket flat head

HSH: hex socket head

HWH: hex washer head

HWHTF: hex washer head thread forming

HYD: hydraulic

LH: left hand

LP: low pressure

LPG: Liquefied Petroleum Gas

NI: nylon insert

NPTF: national pipe thread fine

PFH: phillips flat head

PPH: phillips pan head

PPHTF: phillips pan head thread forming

PRH: phillips round head

PTH: phillips truss head

PTO: power-take-off

RH: right hand

ROPS: roll-over protection system

RRB: rear roller brush

SFH: slotted fillister head

SHH: slotted hex head

SHWH: slotted hex washer head

SPH: slotted pan head

SQH: square head

SRH: slotted round head

STD: standard

TAP: self tapping

TTH: torx truss head

Contents

Frame, Caster Wheel and Roll-Over Protection System Assembly	4
Roll-Over Protection System Assembly No. 116-0231	6
Caster Wheel and Fork Assembly	8
Hydraulic Pump, Idler and Belt Assembly	10
Pump Idler Assembly No. 116-1255	12
LH Hydro Assembly No. 126-1323	14
RH Hydro Assembly No. 126-1324	16
Parking Brake and Wheel Assembly	18
Fuel Tank Mounting Assembly	20
Fuel Tank Assembly No. 116-3978	22
Control Assembly	24
Console and Control Panel Assembly	26
Electrical System Assembly	28
Deck Lift Assembly	30
Height-of-Cut Assembly No. 109-7438	32
Engine, Muffler and Clutch Assembly	34
Deck Assembly	36
Deck Decal Assembly No. 114-5815	38
Idler Assembly	40
Spindle Assembly No. 119-8560	42
Rubber Deflector Assembly No. 108-2792	44
Seat Mount Assembly	46
Suspension Platform Assembly	48
Seat Assembly No. 116-0035	50
Suspension Platform Rubber Mat Assembly	52
Attachments and Accessories	54

Frame, Caster Wheel and Roll-Over Protection System Assembly

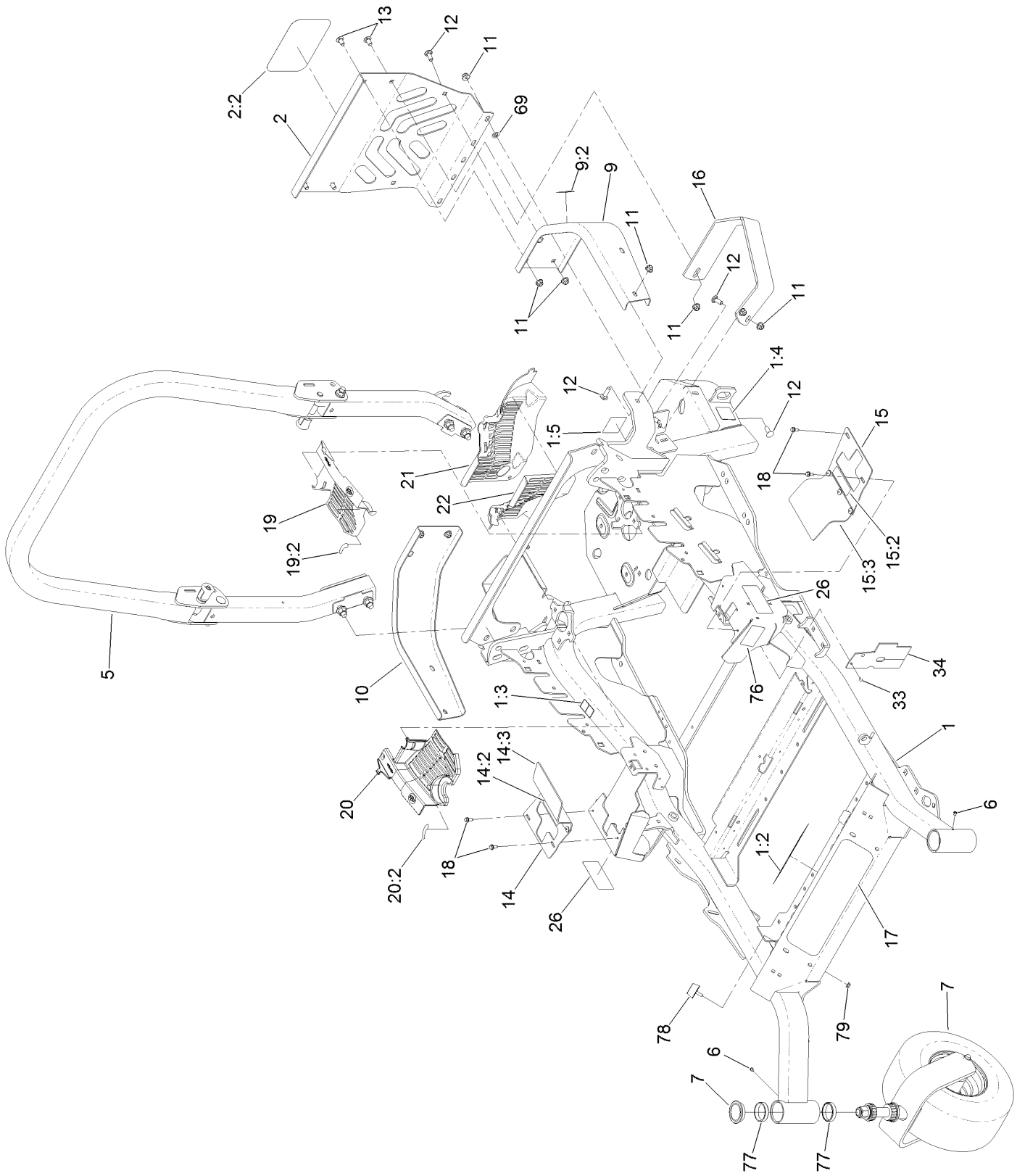

Frame, Caster Wheel and Roll-Over Protection System Assembly (continued)

<i>Ref.</i>	<i>Part Number</i>	<i>Qty.</i>	<i>Description</i>	<i>Ref.</i>	<i>Part Number</i>	<i>Qty.</i>	<i>Description</i>
1	126-6619	1	Mainframe ASM	15	131-4610	1	LH Motion Control Cover ASM
1:2	132-0871	1	Decal-Danger				
1:3	106-5517	2	Decal-Warning, Hot Surface	15:2	99-8936	1	Decal-Control, Motion
1:4	106-2655	2	Decal-Hazard, Pinched Finger	15:3	131-4605	1	Flap-Rubber
1:5	116-4858	1	Decal-Spark Arrester	16	126-2067-03	1	Guard-Muffler
2	115-7410	1	Rear Guard ASM	17	132-5065	1	Decal-Z Master, Commercial
2:2	67-7320	1	Decal	18	32144-10	4	Screw-HWH
5	116-0231	1	ROPS ASM	19	116-0170	1	LH Hydro Guard ASM
6	1-811010	2	Plug	19:2	116-8726	1	Decal-Oil, Hydro
7		2	Caster Wheel ASM ●	20	116-0171	1	RH Hydro Guard ASM
9	116-0180	1	LH Bumper ASM	20:2	116-8726	1	Decal-Oil, Hydro
9:2	106-5517	1	Decal-Warning, Hot Surface	21	109-9057	1	Guard-Hydro, Rear (LH)
10	116-0057-03	1	Bumper-RH	22	109-9058	1	Guard-Hydro, Rear (RH)
11	104-8301	11	Nut-Flange, NI	26	120-5892	2	Decal
12	3231-22	7	Screw-CARR	33	1-803035	2	Rivet-Pop
13	3231-21	3	Screw-CARR	34	116-2362	1	Deflector-Air Flow
14	131-4615	1	RH Motion Control Cover ASM	69	107-3154	2	Nut-Push
14:2	99-8936	1	Decal-Control, Motion	76	117-3864	1	Decal-Fuel Fill, Ce
14:3	131-4605	1	Flap-Rubber	77	1-543508	4	Cup-Bearing
				78	131-8834	2	Bumper
				79	104-7201	2	Nut-Flange, NI

● Not serviced separately

Roll-Over Protection System Assembly No. 116-0231

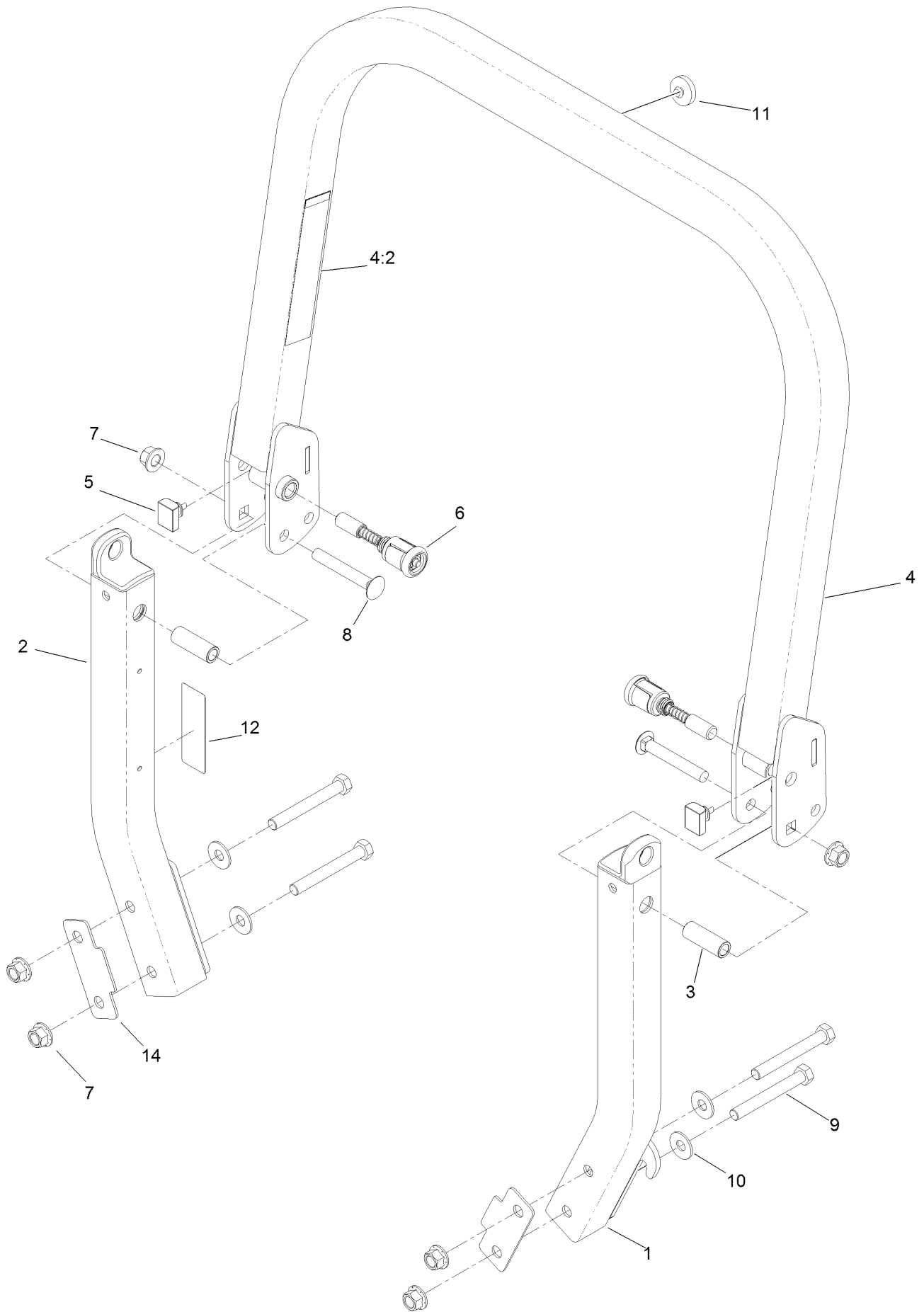

Roll-Over Protection System Assembly No. 116-0231 (continued)

<i>Ref.</i>	<i>Part Number</i>	<i>Qty.</i>	<i>Description</i>	<i>Ref.</i>	<i>Part Number</i>	<i>Qty.</i>	<i>Description</i>
1		1	Leg-ROPS, LH ●	7	99-5107	6	Nut-Lock
2		1	Leg-ROPS, RH ●	8	3233-10	2	Screw-CARR
3	109-6653	2	Spacer	9	325-35	4	Screw-HH
4		1	Upper ROPS ASM ●	10	109-9505	4	Washer-Spring
4:2	107-3069	1	Decal-Warning, Folding ROPS	11	109-9233	1	Bumper-Push-In, Rubber
5	109-5337	2	Bumper-ROPS	12	117-0346	1	Decal-Caution, Fuel Vent
6	116-0104	2	Pin-Spring	14	116-0960	2	Spacer

● Not serviced separately

Caster Wheel and Fork Assembly

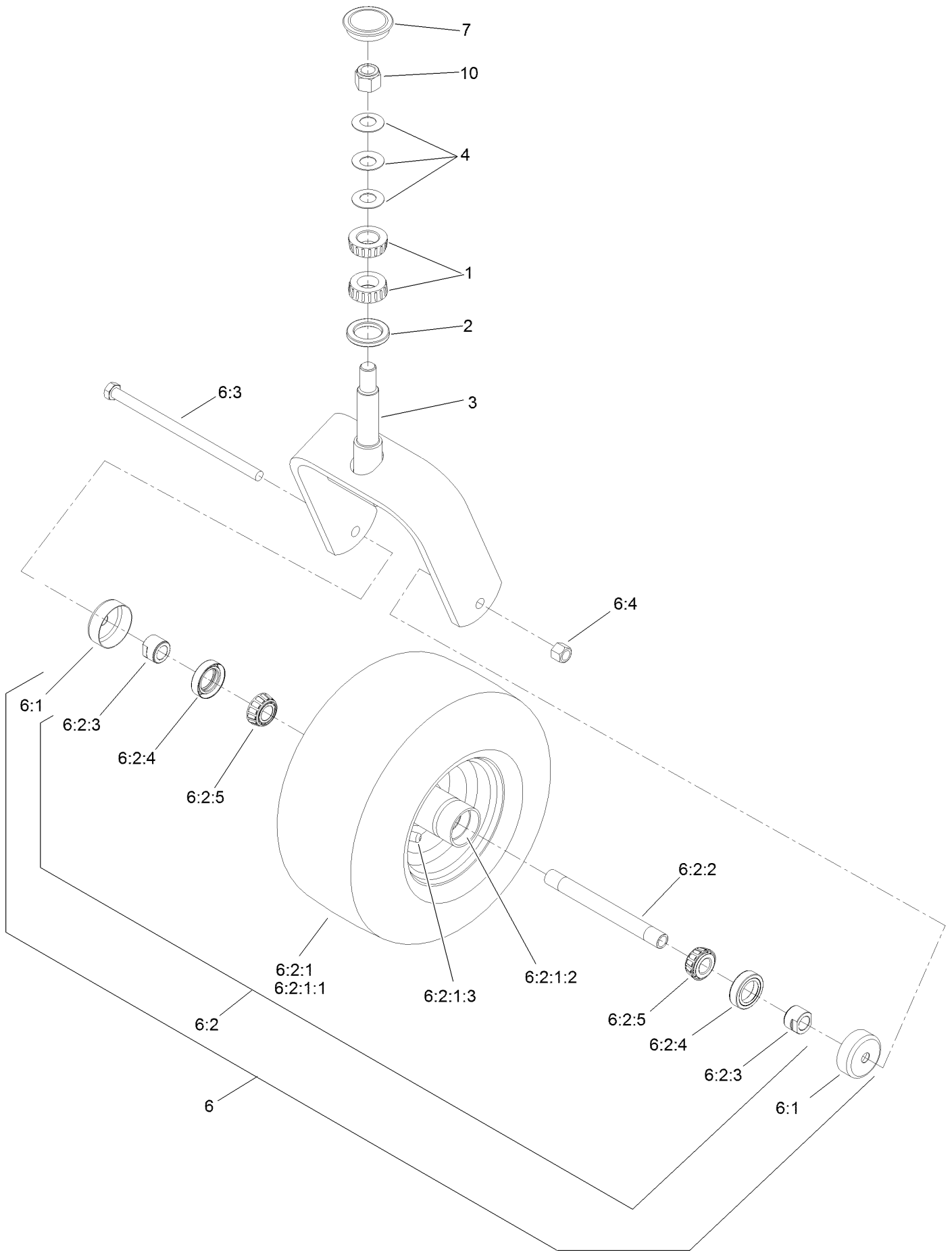

Caster Wheel and Fork Assembly (continued)

<i>Ref.</i>	<i>Part Number</i>	<i>Qty.</i>	<i>Description</i>	<i>Ref.</i>	<i>Part Number</i>	<i>Qty.</i>	<i>Description</i>
1	1-543509	2	Bearing-Roller, Tapered	6:2:1:3	5108	1	Valve
2	116-5647	1	Seal-Grease	6:2:2	103-5156	1	Axle-Caster
3	116-6707-01	1	Caster	6:2:3	103-3051	2	Spacer-Nut
4	1-633508	3	Washer-Bellville	6:2:4	103-0063	2	Seal-Caster
6	127-9540	1	Wheel And Axle ASM	6:2:5	1-633585	2	Bearing-Cone, Taper
6:1	103-2768	2	Guard-Seal	6:3	325-39	1	Screw-HH
6:2		1	Wheel And Bearing ASM ●	6:4	3296-23	1	Nut-Lock, NI
6:2:1		1	Wheel And Tire ASM ●	7	103-4882	1	Cap-Grease
6:2:1:1	1-523009	1	Tire	10	3296-51	1	Nut-Lock, NI
6:2:1:2	1-633584	2	Bearing-Cup				

● Not serviced separately

Hydraulic Pump, Idler and Belt Assembly

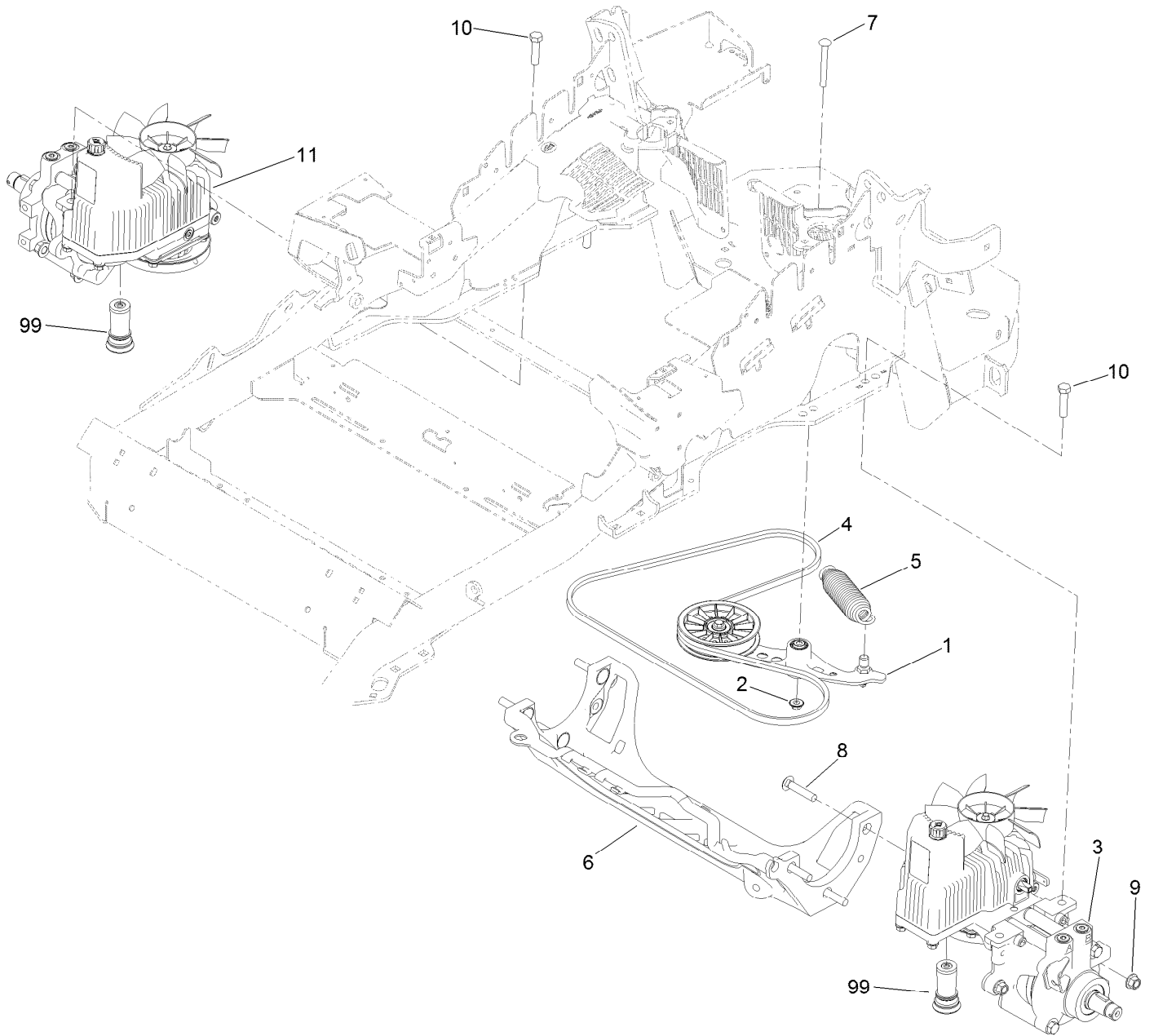

Hydraulic Pump, Idler and Belt Assembly (continued)

<i>Ref.</i>	<i>Part Number</i>	<i>Qty.</i>	<i>Description</i>	<i>Ref.</i>	<i>Part Number</i>	<i>Qty.</i>	<i>Description</i>
1	116-1255	1	Pump Idler ASM	9	99-5107	6	Nut-Lock
2	109-6658	1	Nut-Flange, NI	10	325-8	4	Screw-HH
3	126-1323	1	LH Hydro ASM (12Cc W/ Shock)	11	126-1324	1	RH Hydro ASM (12Cc W/ Shock)
4	109-3388	1	Belt	99	114-4713	1	Hypr-Oil 500 (Quart) ●
5	116-6317	1	Spring-Extension	99	114-4714	1	Hypr-Oil 500 (Gallon) ●
6	116-7558	1	Cradle-Hydro	99	114-4715	1	Hypr-Oil 500-5 (5 Gallon) ●
7	116-1502	1	Bolt-Shoulder, Carriage	99	117-0390	1	Filter-Hydro
8	126-0095	6	Screw-CARR				

● Not illustrated

Pump Idler Assembly No. 116-1255

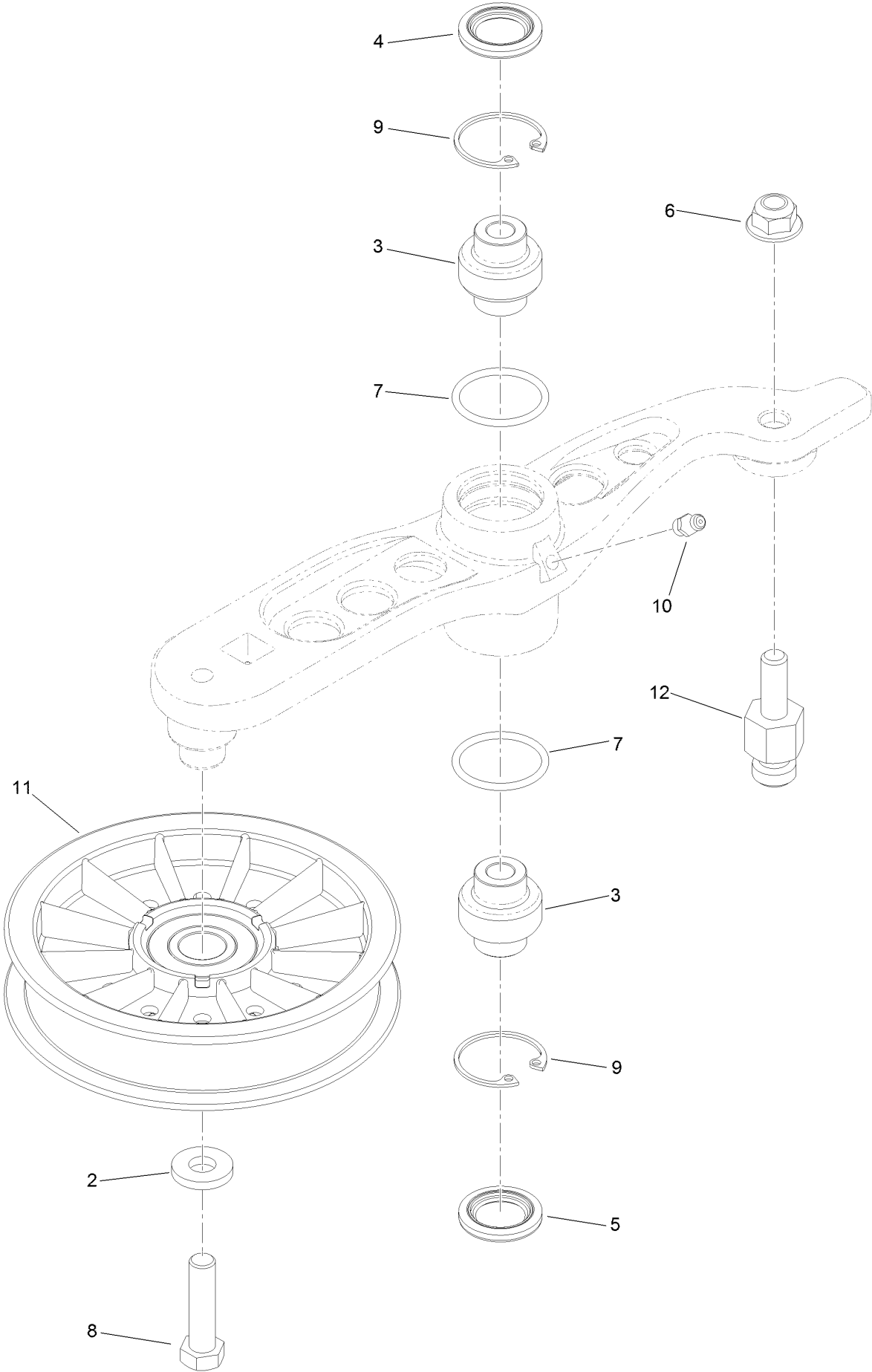

Pump Idler Assembly No. 116-1255 (continued)

<i>Ref.</i>	<i>Part Number</i>	<i>Qty.</i>	<i>Description</i>	<i>Ref.</i>	<i>Part Number</i>	<i>Qty.</i>	<i>Description</i>
2	43-0940	1	Spacer	8	323-8	1	Screw-HH
3	103-3504	2	Bearing-Spherical	9	32120-10	2	Ring-Snap
4	103-3505	1	Seal-Double Lip	10	302-19	1	Fitting-Grease
5	103-3506	1	Seal-Lip, Single	11	109-8076	1	Pulley-Idler
6	109-6658	1	Nut-Flange, NI	12	116-3467	1	Pin-Spring, Anchor
7	106-7159	2	O-Ring				

LH Hydro Assembly No. 126-1323

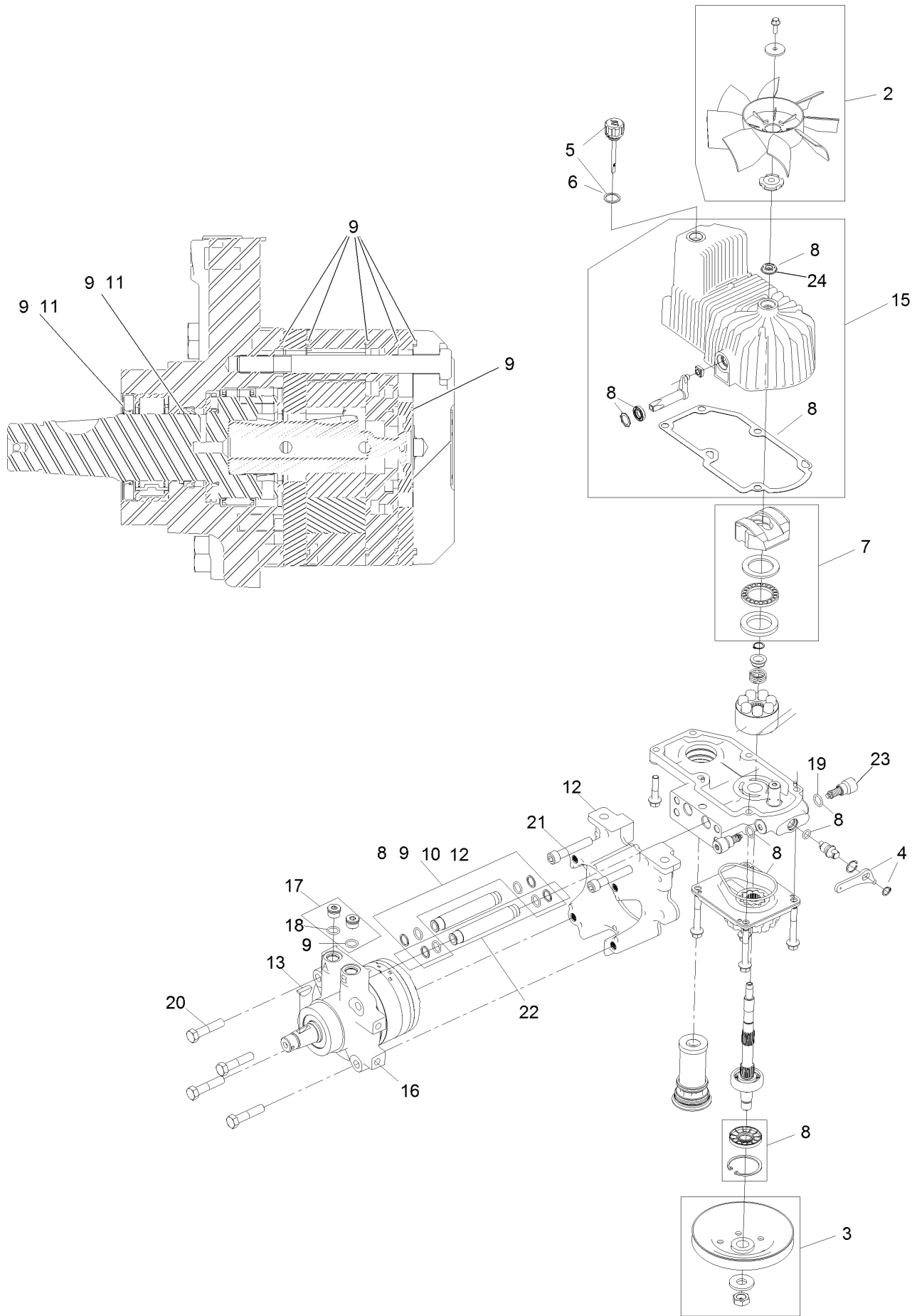

LH Hydro Assembly No. 126-1323 (continued)

<i>Ref.</i>	<i>Part Number</i>	<i>Qty.</i>	<i>Description</i>	<i>Ref.</i>	<i>Part Number</i>	<i>Qty.</i>	<i>Description</i>
2	116-0233	1	Fan Kit	15	116-3287	1	Housing-LH
3	116-0234	1	Pulley Kit	16	116-8915	1	Motor-Hydraulic LH 240Cc
4	116-0235	1	Handle-Bypass Valve, Hydro	17	116-7901	1	Magnetic Plugs Service Kit
5	116-0236	1	Dipstick-Hydro W/Gasket	18	76-1900	2	O-Ring
6	116-0237	1	Gasket-Dipstick, Hydro	19	116-8662	2	O-Ring-Check Valve
7	116-1367	1	Swash Block Kit	20	116-8974	4	Screw-HH 1/2-20 X 2 1/4
8	116-1368	1	Pump Seal Kit	21	116-8975	2	Screw-HSH 1/2-20 X 2 3/4
9	116-1369	1	Motor Seal Kit	22	116-9922	2	Hydraulic Tube Kit
10	116-1370	1	Tube Seal Kit	23	126-7466	2	Shock Valve, 12Cc Hydro
11	116-1371	1	Output Shaft Seal Kit	24	126-7711	1	Seal-Fan Drive
12	116-5469	1	Nose Cup-Uht	99	116-4245	1	Puller-Pulley ●
13	3257-42	1	Key-Woodruff 5/16 X 1	99	116-1373	1	Flow Test Kit ●

● Not illustrated

RH Hydro Assembly No. 126-1324

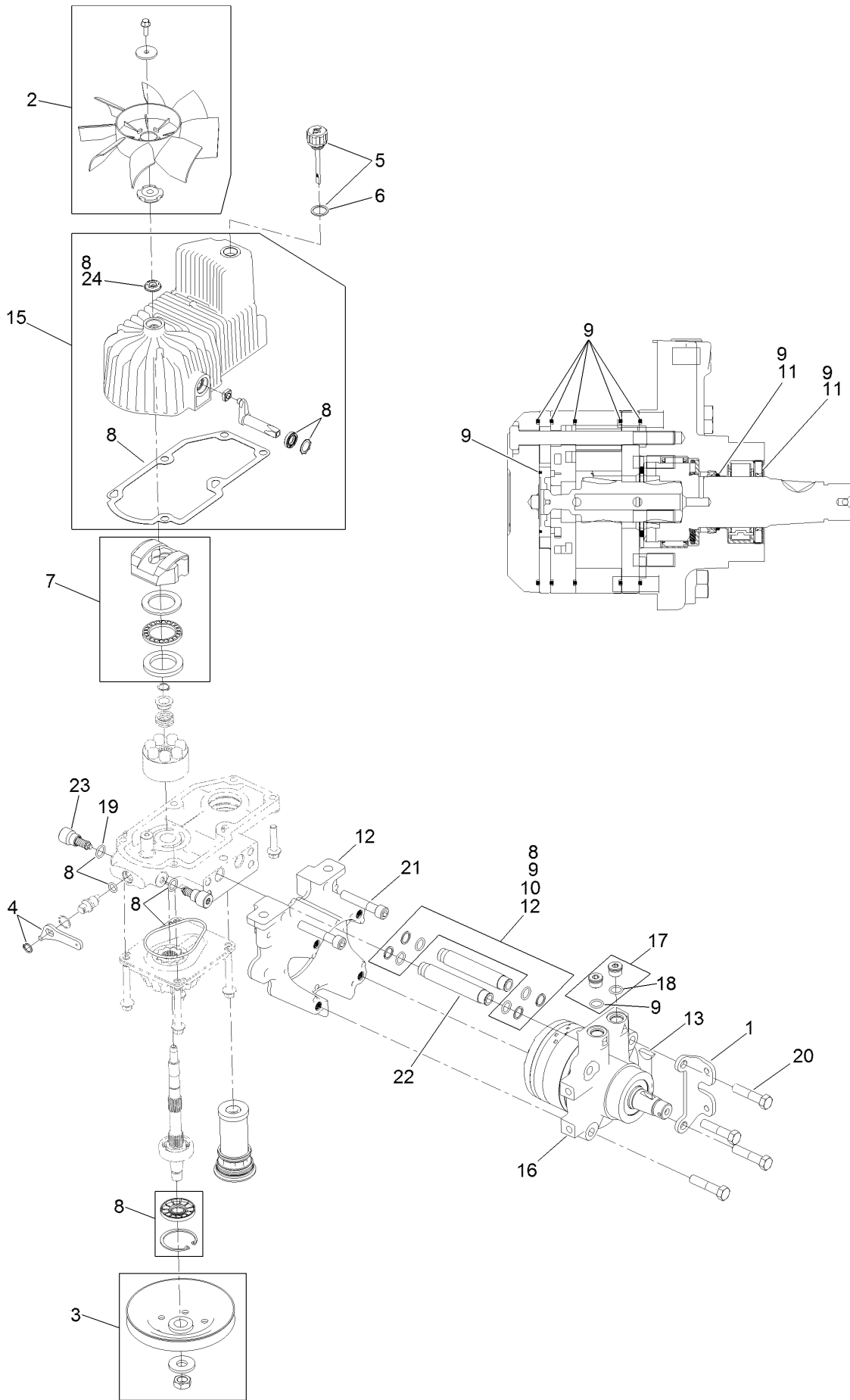

RH Hydro Assembly No. 126-1324 (continued)

<i>Ref.</i>	<i>Part Number</i>	<i>Qty.</i>	<i>Description</i>	<i>Ref.</i>	<i>Part Number</i>	<i>Qty.</i>	<i>Description</i>
1	116-9063	1	Mount-Shoe, Horse	13	3257-42	1	Key-Woodruff
2	116-0233	1	Fan Kit	15	116-3288	1	Housing-RH
3	116-0234	1	Pulley Kit	16	116-8916	1	Motor-Hydraulic RH 240Cc
4	116-0235	1	Handle-Bypass Valve, Hydro	17	116-7901	1	Magnetic Plugs Service Kit
5	116-0236	1	Dipstick-Hydro W/Gasket	18	76-1900	2	O-Ring
6	116-0237	1	Gasket-Dipstick, Hydro	19	116-8662	2	O-Ring-Check Valve
7	116-1367	1	Swash Block Kit	20	116-8974	4	Screw HH
8	116-1368	1	Pump Seal Kit	21	116-8975	2	Screw-HSH
9	116-1369	1	Motor Seal Kit	22	116-9922	2	Hydraulic Tube Kit
10	116-1370	1	Tube Seal Kit	23	126-7466	2	Shock Valve, 12Cc Hydro
11	116-1371	1	Output Shaft Seal Kit	24	126-7711	1	Seal-Fan Drive
12	116-5469	1	Nose Cup-Uht	99	116-4245	1	Puller-Pulley ●
				99	116-1373	1	Flow Test Kit ●

● Not illustrated

Parking Brake and Wheel Assembly

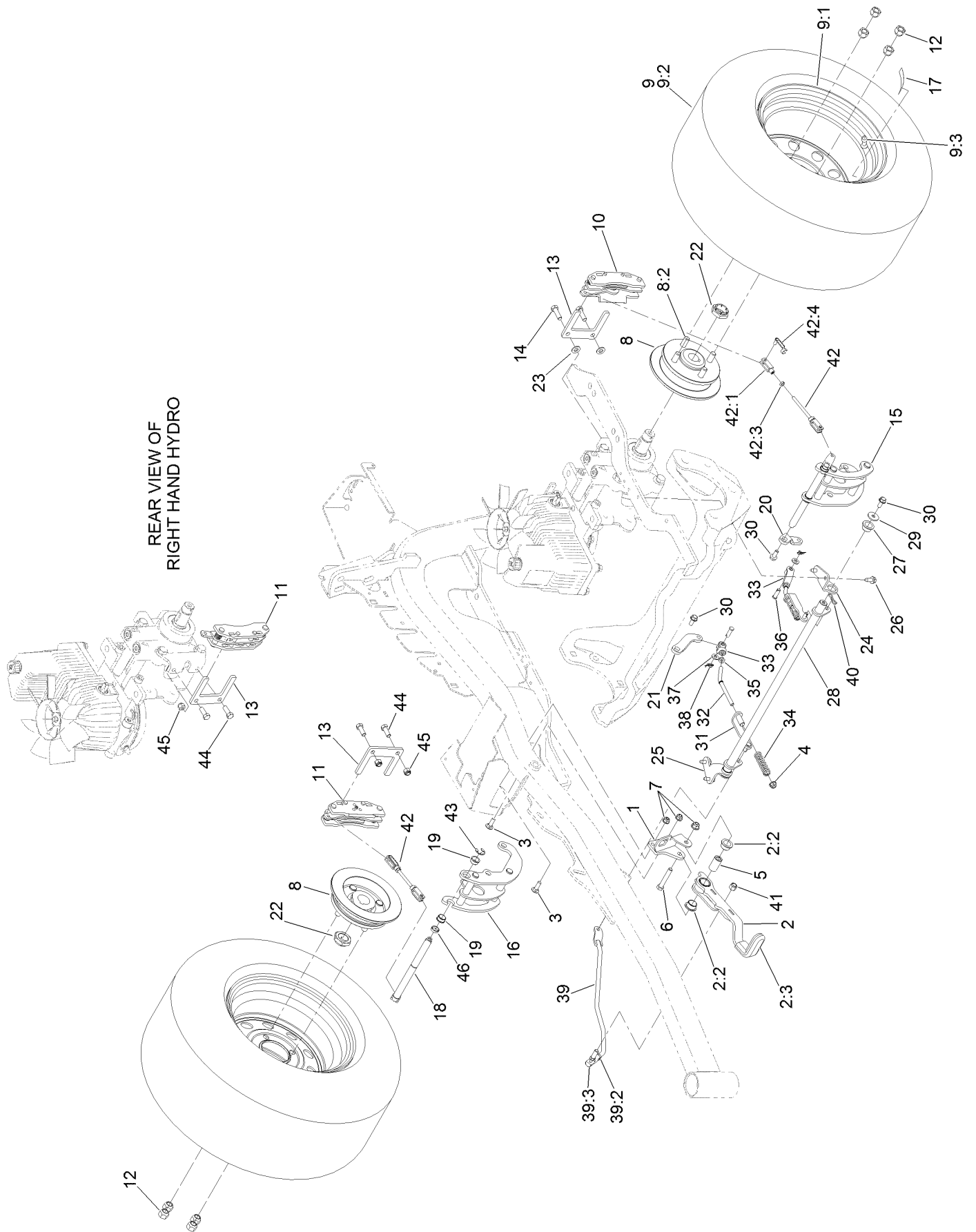

Parking Brake and Wheel Assembly (continued)

<i>Ref.</i>	<i>Part Number</i>	<i>Qty.</i>	<i>Description</i>	<i>Ref.</i>	<i>Part Number</i>	<i>Qty.</i>	<i>Description</i>
1	116-9096-01	1	Bracket-Mount	23	3256-24	2	Washer-Flat
2	131-4623	1	Brake Lever ASM W/ Grip	24	116-9681	1	Mount-Pivot, LH
2:2	109-8054	2	Bushing-Flange	25	116-9682	1	Mount-Pivot, RH
2:3	1-633268	1	Grip-Lever	26	32144-70	4	Screw-HWHTF
3	3230-2	2	Bolt-CARR	27	109-8054	2	Bushing-Flange
4	104-8300	4	Nut-Flange, NI	28	116-9080	1	Shaft-Cross
5	116-9117	1	Handle-Pivot, Brake	29	115-7109	2	Washer-Flat
6	323-11	1	Screw-HH	30	98-9940	4	Screw
7	104-8301	1	Nut-Flange, NI	31	116-9609	2	Bracket-L
8	116-1746	2	Wheel Hub ASM	32	116-9086	2	Linkage-Mid
8:2	116-1696	4	Stud-Wheel	33	126-3693	2	Yoke-Offset
9	127-9520	2	Wheel And Tire ASM	34	116-9085	2	Spring-Compression
9:1	127-9517	1	Wheel	35	3220-2	2	Nut-Jam
9:2	1-633993	1	Tire	36	1-808280	2	Pin-Clevis
9:3	232-27	1	Stem-Valve	37	3256-23	4	Washer-Flat
10	109-2889	1	Caliper-Brake	38	116-6639	2	Pin-Cotter, Locking
11	116-9103	1	Caliper-Brake, RH	39	116-9102	1	Front Linkage ASM
12	242-50	8	Nut-Lug	39:2	94-7572	1	End-Tie Rod, RH
13	109-0958	2	Plate-Mount, Brake	39:3	3220-3	1	Nut-HJ
14	92-5727	2	Screw-Lock, Patch	40	119-1415	2	Pin-Cotter, Locking
15	126-4248	1	Mount-Bellcrank, LH	41	3296-6	1	Nut-Lock
16	126-4249	1	Mount-Bellcrank, RH	42	116-9071	2	Rear Linkage ASM
17	126-2055	2	Decal-Torque, Wheel Hub Lug	42:1	116-9070	2	Yoke
18	126-4251	2	Bellcrank	42:3	3220-1	1	Nut-Jam
19	126-6199	4	Bushing-Igus	42:4	126-6395	2	Pin-Clevis, Spring
20	126-3715	1	Arm-Inner, LH	43	32120-19	2	E-Ring
21	126-3716	1	Arm-Inner, RH	44	323-6	2	Screw-HH
22	116-1399	2	Locknut	45	3296-39	2	Nut-Lock, NI
				46	126-6200	2	Spacer

Fuel Tank Mounting Assembly

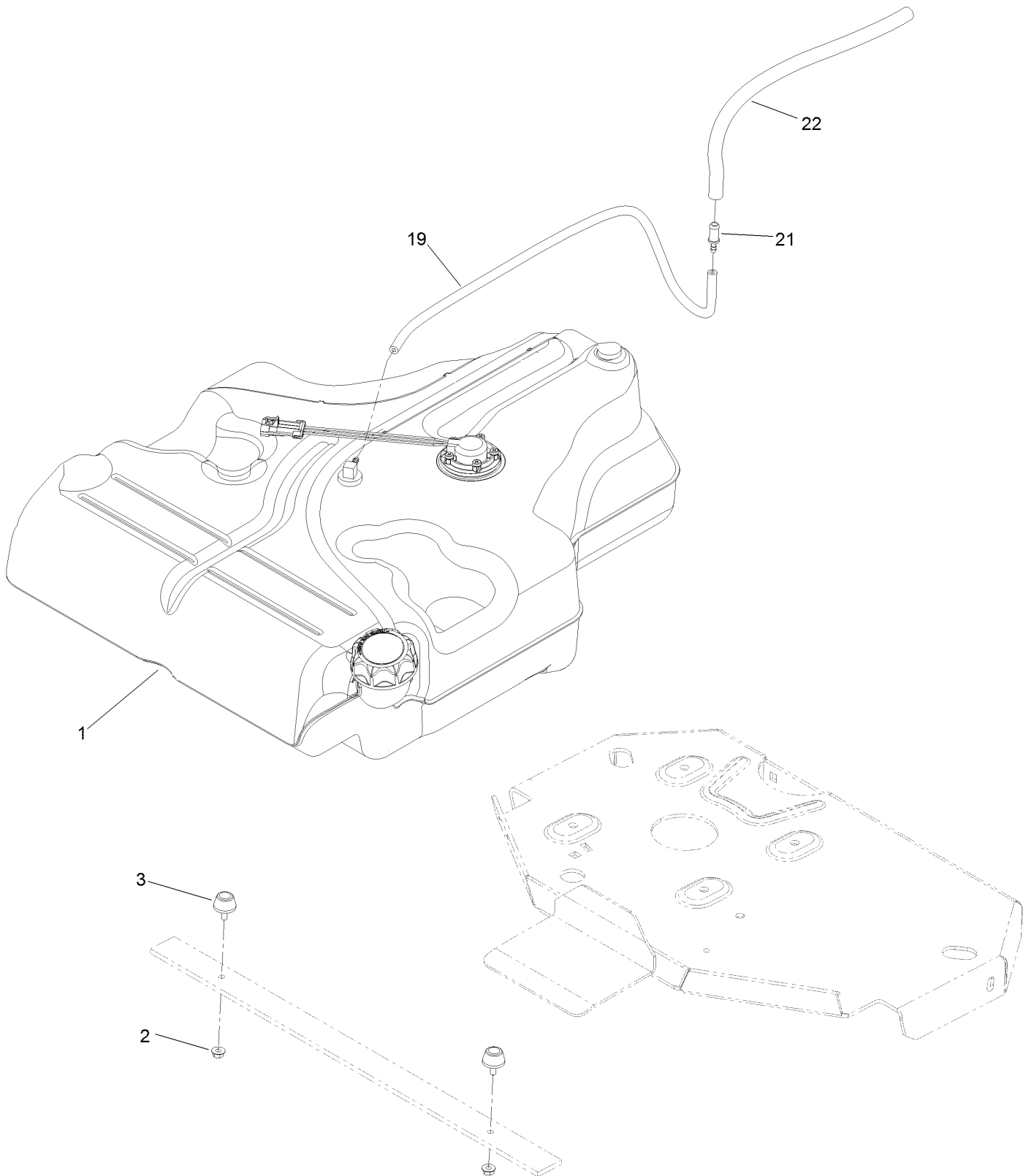

Fuel Tank Mounting Assembly (continued)

<i>Ref.</i>	<i>Part Number</i>	<i>Qty.</i>	<i>Description</i>	<i>Ref.</i>	<i>Part Number</i>	<i>Qty.</i>	<i>Description</i>
1	116-3978	1	Fuel Tank ASM	19	110-8751	1	Hose-Fuel
2	3218-1	2	Nut-Jam	21	98-2952	1	Fitting-Straight
3	116-6380	2	Bumper-Rubber (W/ Stud)	22	116-4344	1	Hose-Fuel

Fuel Tank Assembly No. 116-3978

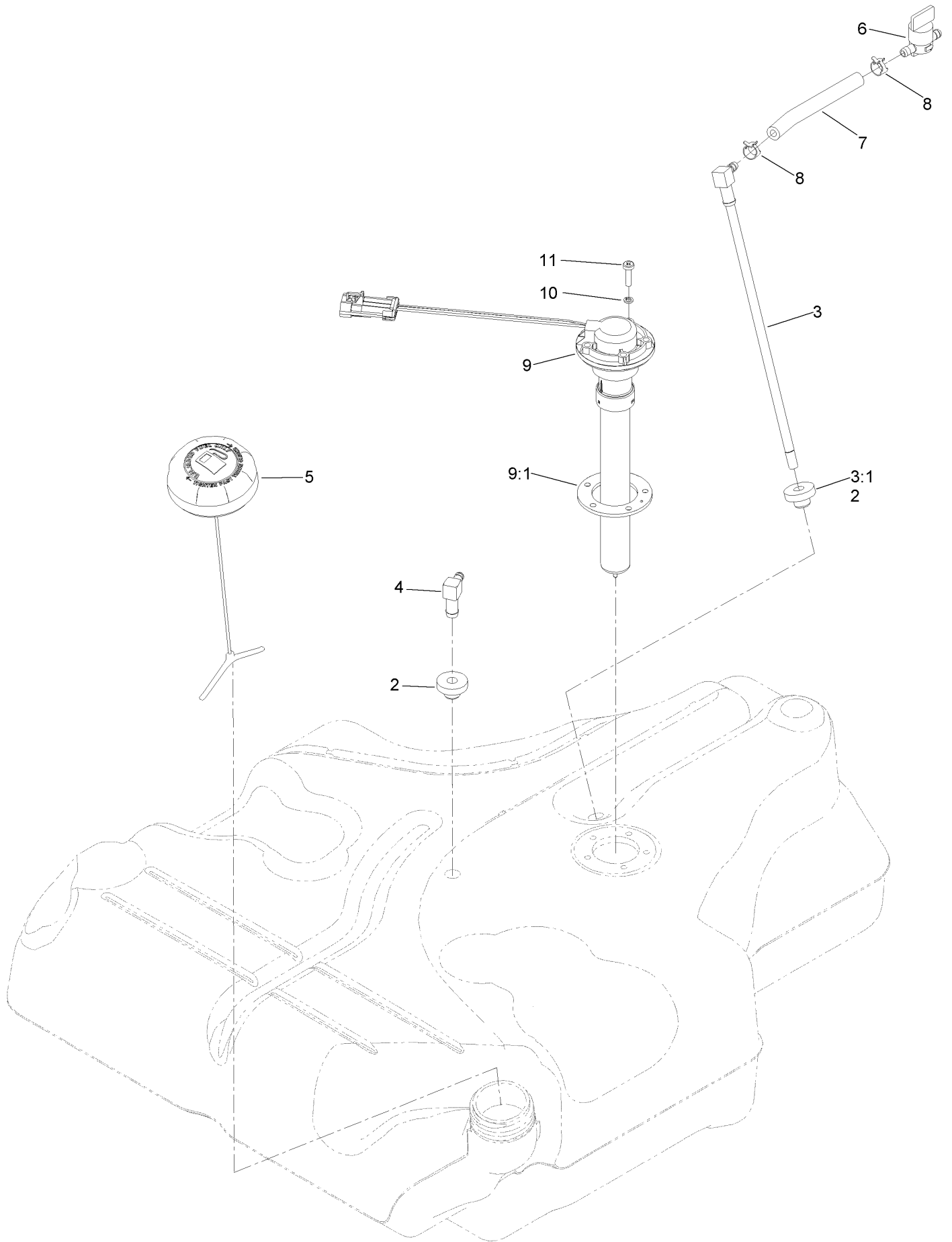

Fuel Tank Assembly No. 116-3978 (continued)

<i>Ref.</i>	<i>Part Number</i>	<i>Qty.</i>	<i>Description</i>	<i>Ref.</i>	<i>Part Number</i>	<i>Qty.</i>	<i>Description</i>
2	46-6560	2	Bushing	7	109-0650	1	Hose-Fuel
3	116-2459	1	Fuel Line Kit (With Grommet)	8	2412-98	2	Clamp-Hose
3:1	46-6560	1	Bushing	9	116-1981	1	Sender-Fuel
4	116-2288	1	Fitting-90 Elbow	9:1	109-9620	1	Gasket-Sender, Fuel
5	126-1789	1	Cap-Fuel, Ratcheting	10	3253-17	5	Washer-Lock
6	1-603770	1	Valve-Fuel	11	9107944	5	Screw-Pan

Control Assembly

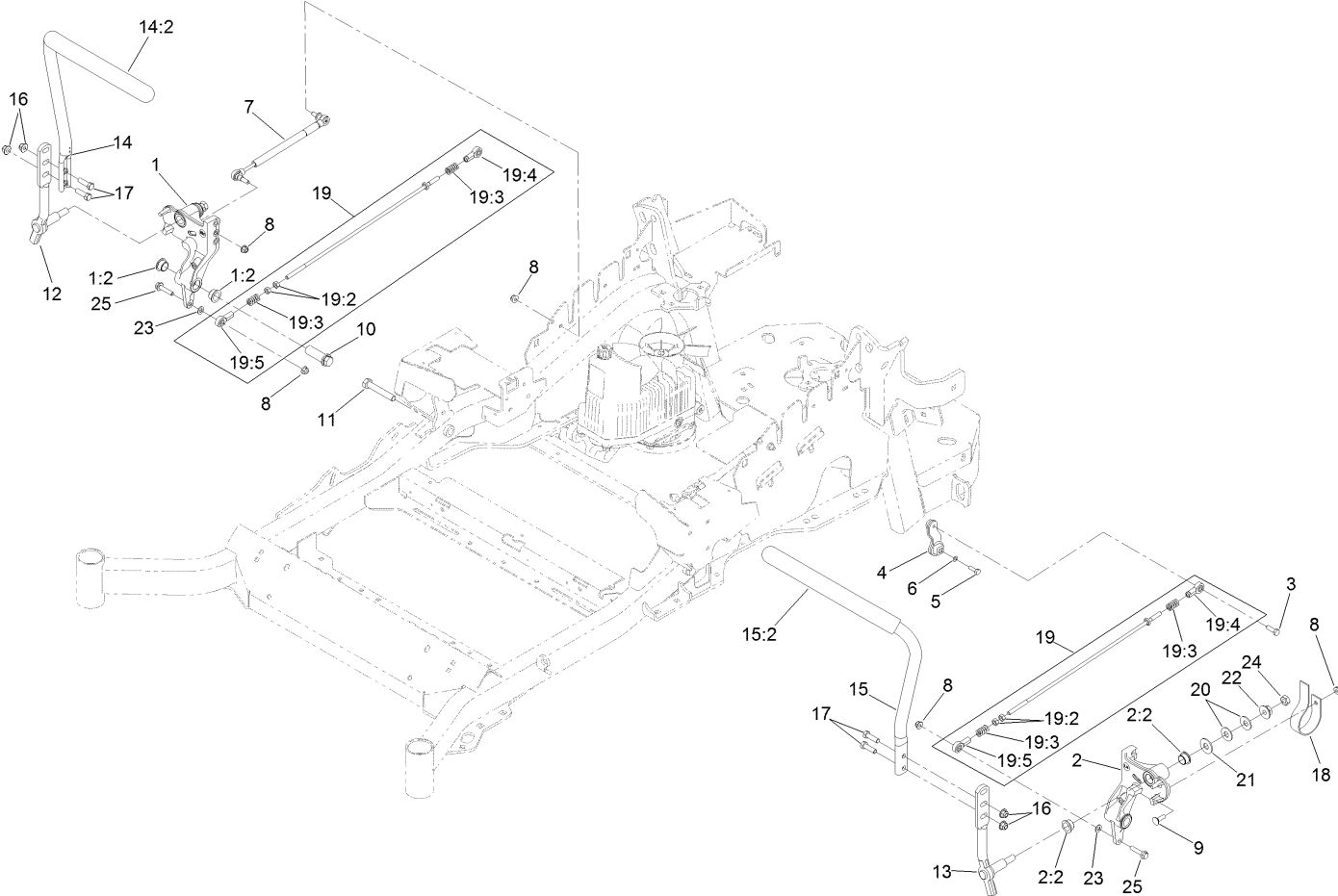

Control Assembly (continued)

<i>Ref.</i>	<i>Part Number</i>	<i>Qty.</i>	<i>Description</i>	<i>Ref.</i>	<i>Part Number</i>	<i>Qty.</i>	<i>Description</i>
1	116-0880	1	RH Motion Control And Bushing ASM	14	131-8831	1	RH Steering Handle ASM
1:2	109-8054	4	Bushing-Flange	14:2	109-5668	1	Grip-Control, Lever
2	116-0881	1	LH Motion Control And Bushing ASM	15	131-8832	1	LH Steering Handle ASM
2:2	109-8054	4	Bushing-Flange	15:2	109-5668	1	Grip-Control, Lever
3	116-0648	2	Screw-HH, Thread Locking ●	16	104-8301	4	Nut-Flange, NI
4	109-4581	2	Arm-Control, Pump	17	323-7	4	Screw-HH
5	9080046	2	Screw-HH ●	18	109-5575	2	Spring-Leaf
6	1-303435	2	Washer-Spring	19	109-8106	2	Front Pump Linkage ASM
7	116-0027	2	Damper-Control, Motion	19:2	3219-2	2	Nut-Hex
8	104-8300	8	Nut-Flange, NI	19:3	1-323245	2	Spring-Compression
9	3230-2	2	Bolt-CARR	19:4	1-633152	1	Balljoint-LH
10	109-5891	2	Hub-Threaded	19:5	1-543017	1	Balljoint-RH
11	325-12	2	Screw-HH	20	109-9505	4	Washer-Spring
12	116-0039	1	Lever-Control Motion, RH	21	3256-6	2	Washer-Flat
13	116-0040	1	Lever-Control Motion, LH	22	32128-56	2	Nut-HF
				23	3256-23	2	Washer-Flat
				24	3218-5	2	Nut-Jam
				25	115-1794	2	Screw-HHF

● Use Pro-Lock, Nut Type (P/N 1-840022, .5ml tube) on threads.

Console and Control Panel Assembly

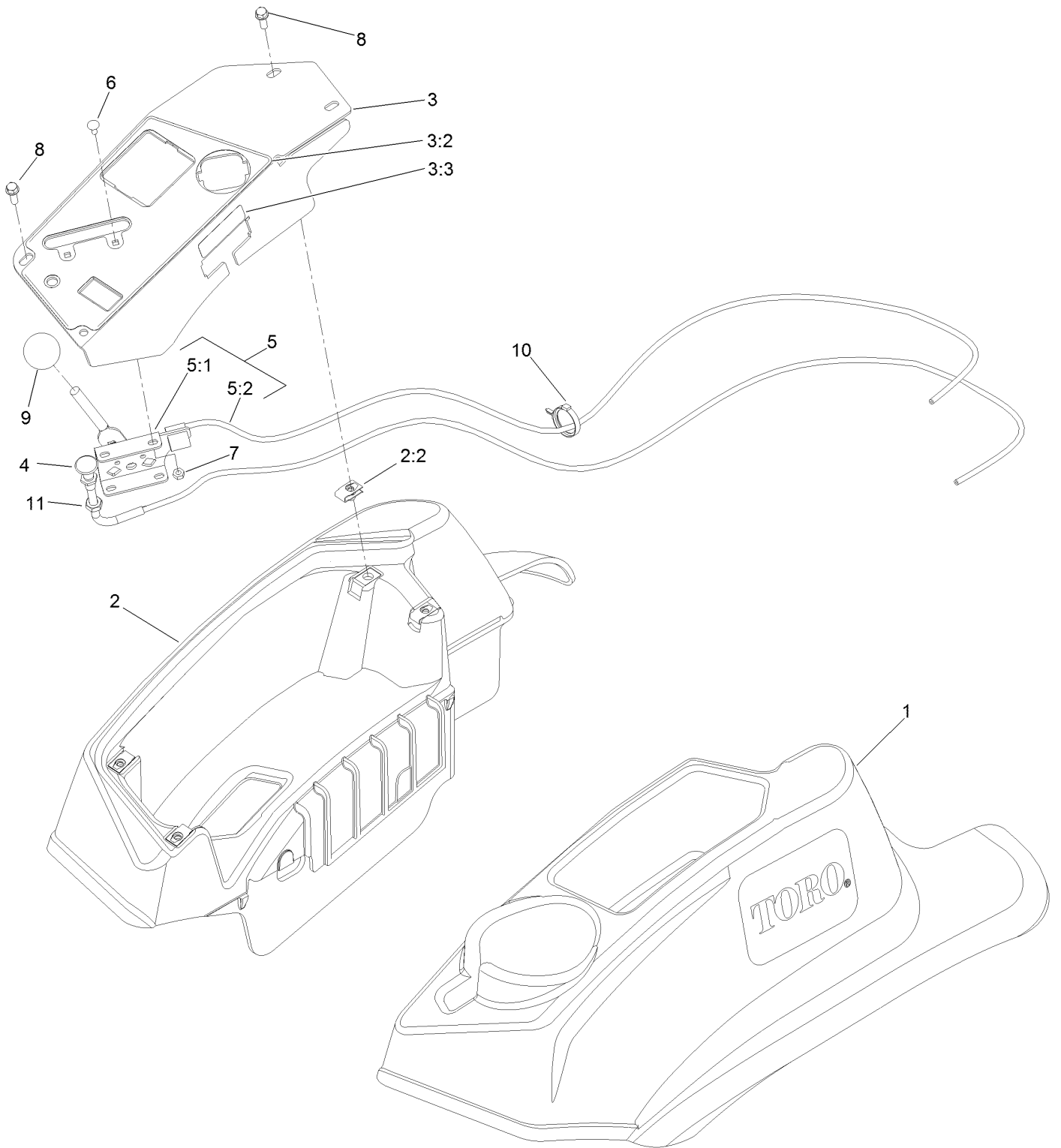

Console and Control Panel Assembly (continued)

<i>Ref.</i>	<i>Part Number</i>	<i>Qty.</i>	<i>Description</i>	<i>Ref.</i>	<i>Part Number</i>	<i>Qty.</i>	<i>Description</i>
1	119-2602	1	Console-LH	5:1	112-2334	1	Lever-Throttle
2	119-2603	1	RH Console ASM	5:2	110-5728	1	Cable-Throttle
2:2	107069	4	Clip	6	1-807513	2	Bolt-CARR
3	119-6663	1	Control Panel ASM	7	3296-2	2	Nut-Lock, NI
3:2	121-7551	1	Decal-Control Panel	8	32105-15	4	Screw-HWH
3:3	114-4466	1	Decal-Fuses	9	1-603175	1	Knob-Ball
4	115-2753	1	Control-Choke	10	117-7817	1	Clamp-Harness
5	110-5727	1	Throttle Control ASM	11	3220-3	1	Nut-HJ

Electrical System Assembly

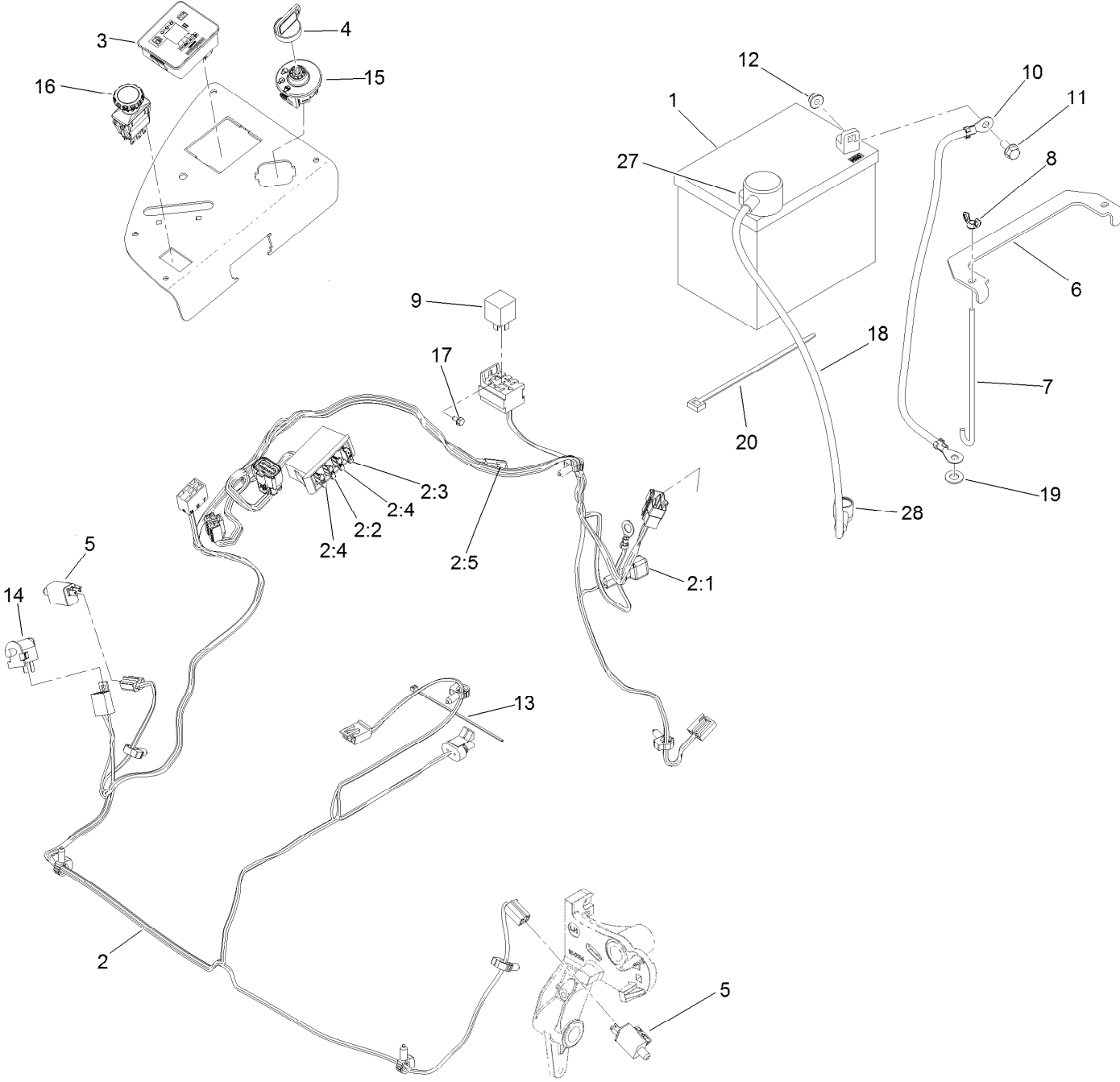

Electrical System Assembly (continued)

<i>Ref.</i>	<i>Part Number</i>	<i>Qty.</i>	<i>Description</i>	<i>Ref.</i>	<i>Part Number</i>	<i>Qty.</i>	<i>Description</i>
1	104-8162	1	Battery-Dry	10	114-1218	1	Cable-Battery, Negative
2	116-6009	1	Harness-Wire, Main ●	11	3234-5	2	Screw-HHF
2:1	103-3895	1	Diode	12	104-8300	2	Nut-Flange, NI
2:2	218-578	1	Fuse-Blade, 10 Amp	13	1-303287	3	Tie-Cable
2:3	109355	1	Fuse-Blade, 15 Amp	14	82-2190	1	Switch-Bail
2:4	109102	2	Fuse-Blade, 25 Amp	15	117-2221	1	Switch-Ignition
2:5	116-0053	1	Cap-Plug	16	116-0124	1	Switch-PTO, 10 Amp
3	117-3882	1	Fuel/Hour Meter ASM	17	104-2065	1	Screw-HWH
4	63-8360	1	Key-Ignition	18	115-3864	1	Cable-Battery, Positive
5	110-6765	2	Switch	19	3256-24	1	Washer-Flat
6	116-0042-03	1	Strap-Tie Down, Battery	20	1-303335	1	Tie-Plastic
7	1-633651	2	Bolt-Holddown	27	109-2407	1	Insulator-Battery
8	1-543792	2	Wingnut	28	1-543393	1	Insulator-Solenoid
9	1-643275	1	Relay				

● Use dielectric grease on all unsealed connectors and terminals only. Do not apply in sealed connectors.

Deck Lift Assembly

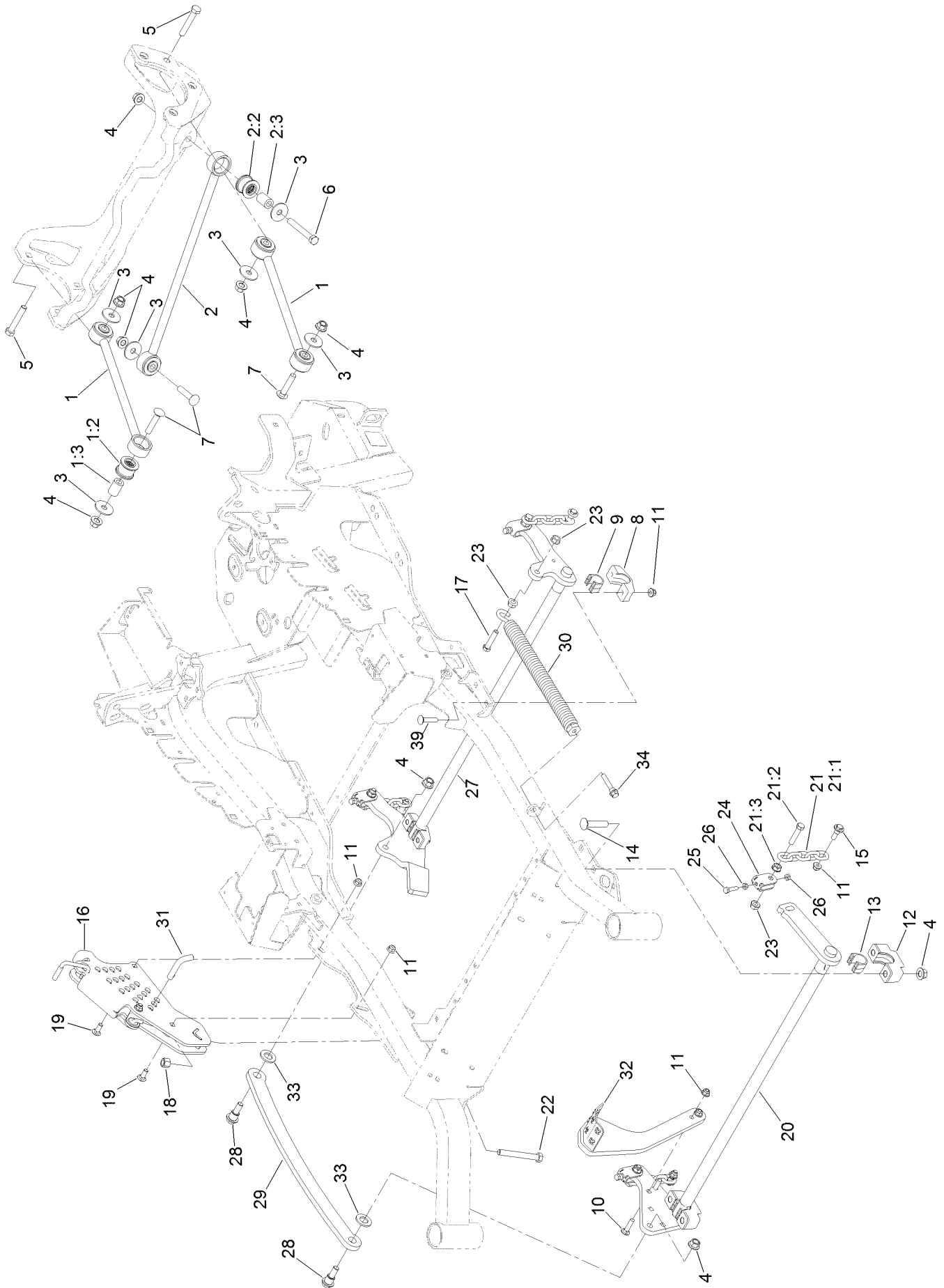

Deck Lift Assembly (continued)

<i>Ref.</i>	<i>Part Number</i>	<i>Qty.</i>	<i>Description</i>	<i>Ref.</i>	<i>Part Number</i>	<i>Qty.</i>	<i>Description</i>
1	109-7952	2	Deck Strut ASM	16	109-7438	1	HOC ASM
1:2	109-5009	2	Bushing-Suspension, Rubber	17	109-9065	1	Screw-HH
1:3	109-5010	2	Spacer	18	3296-23	1	Nut-Lock, NI
2	109-5013	1	Panhard Rod ASM	19	3231-2	2	Bolt-CARR
2:2	109-5009	2	Bushing-Suspension, Rubber	20	126-2475-03	1	Decklift-Front
2:3	109-5010	2	Spacer	21	116-0756	4	Deck Lift Chain ASM
3	86-1990	6	Washer-Thrust	21:1	1-633447	1	Chain-Lift, Deck
4	99-5107	12	Nut-Lock	21:2	109-9065	1	Screw-HH
5	325-12	2	Screw-HH	21:3	32128-37	1	Nut-HF
6	325-17	1	Screw-HH	22	116-0559	1	Bolt-TAP
7	3233-34	3	Screw-CARR	23	32128-37	6	Nut-HF
8	116-0818-03	2	Support-Cross Shaft, Rear Bearing	24	109-9066	4	Yoke-Adjust, Deck
9	109-7173	2	Bearing-Cross Shaft, Rear	25	322-47	4	Screw-HH
10	3231-4	2	Screw-CARR	26	3218-2	8	Nut-Jam
11	104-8301	12	Nut-Flange, NI	27	116-0459-03	1	Lift-Deck, Rear
12	109-9409	2	Support-Cross Shaft, Bearing	28	116-0780	2	Screw-Shoulder, HHF
13	109-9410	2	Bearing-Cross Shaft, Front	29	116-0797-03	1	Link-Lift, Deck
14	116-1700	4	Bolt-CARR	30	116-0000	1	Spring-Extension
15	109-9840	4	Screw-Shoulder, HHF	31	116-5584	1	Pin-HOC
				32	131-8812-01	1	Lever-Foot
				33	3256-28	2	Washer-Flat
				34	92-7674	1	Bolt-Shoulder
				39	3231-5	4	Screw-CARR

Height-of-Cut Assembly No. 109-7438

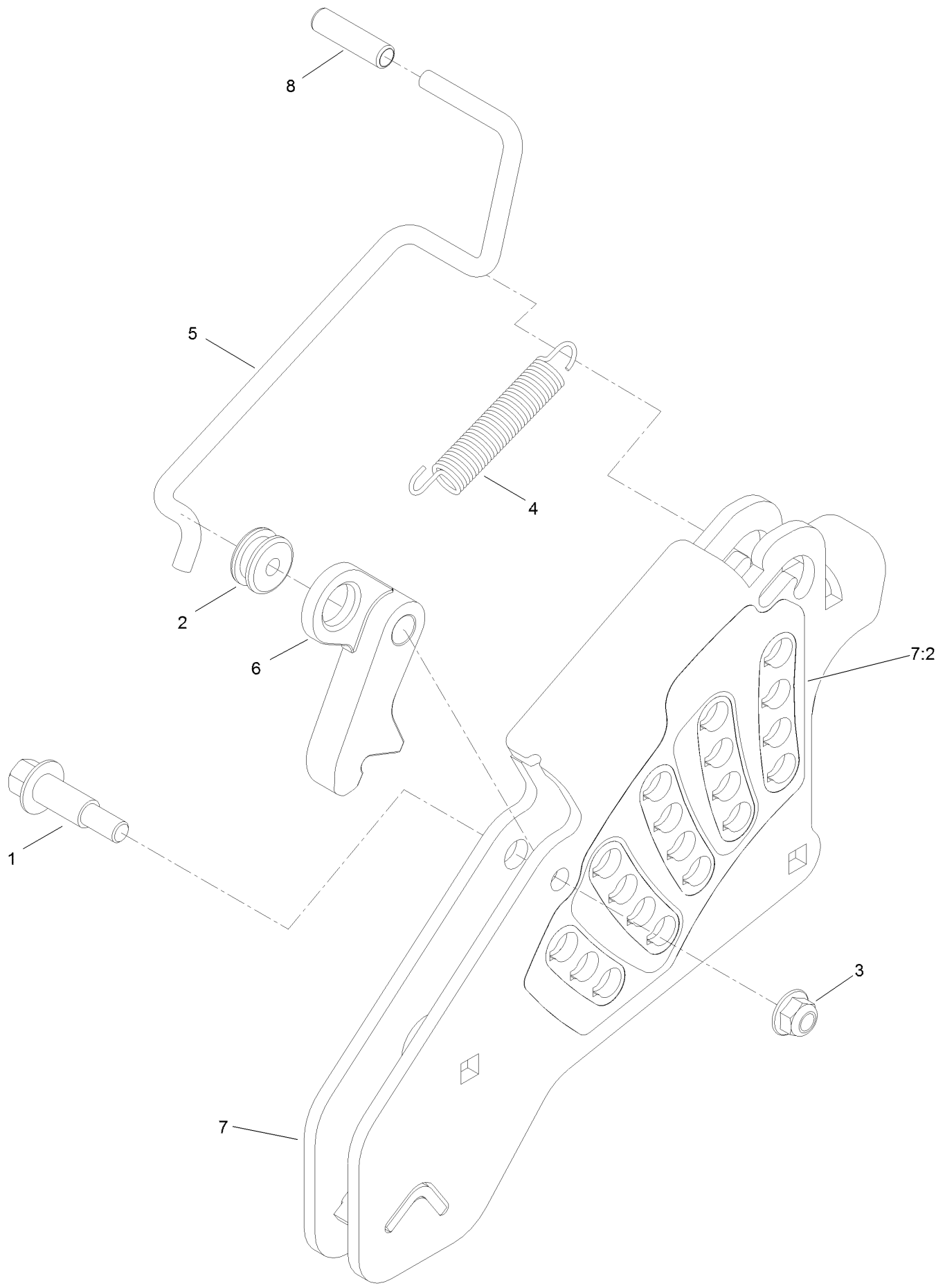

Height-of-Cut Assembly No. 109-7438 (continued)

<i>Ref.</i>	<i>Part Number</i>	<i>Qty.</i>	<i>Description</i>	<i>Ref.</i>	<i>Part Number</i>	<i>Qty.</i>	<i>Description</i>
1	62-1330	1	Bolt-Shoulder	6	116-0118	1	Pawl-Transport, HOC
2	109-7130	1	Grommet	7	109-7335	1	HOC Plate ASM
3	104-8301	1	Nut-Flange, NI	7:2	126-4398	1	Decal-HOC
4	109-7124	1	Spring-Extension	8	109-8250	1	Grip-Lever
5	109-7128	1	Rod-Lock, Transport				

Engine, Muffler and Clutch Assembly

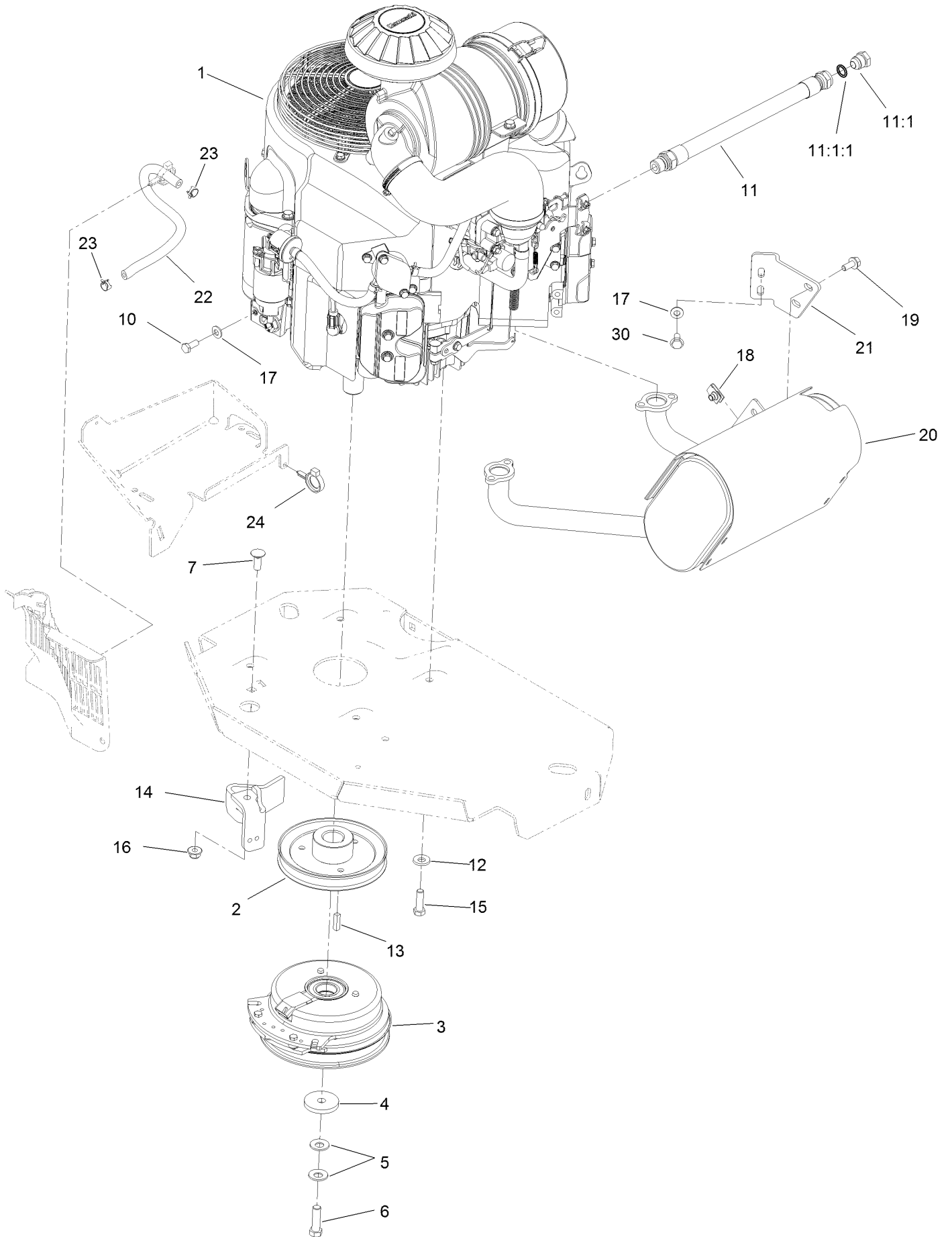

Engine, Muffler and Clutch Assembly (continued)

<i>Ref.</i>	<i>Part Number</i>	<i>Qty.</i>	<i>Description</i>	<i>Ref.</i>	<i>Part Number</i>	<i>Qty.</i>	<i>Description</i>
1		1	Engine-Kawasaki, Fx801V-S04-R ●■	13	1-807259	1	Key
2	109-9905	1	Sheave	14	116-2612-01	1	Clutch-Anchor
3	116-1620	1	Clutch Kit	15	323-7	4	Screw-HH
4	109-6919	1	Washer-Clutch	16	104-8301	1	Nut-Flange, NI
5	1-603610	2	Washer-Spring	17	1-303334	3	Washer-Spring
6	109-9761	1	Screw-HH ▲	18	94-2413	2	Nut-U
7	3231-22	1	Screw-CARR	19	3234-5	2	Screw-HHF
10	33114-020	1	Screw-HH	20	116-1712	1	Muffler
11	116-4924	1	Engine Oil Drain Hose ASM	21	116-0203	1	Bracket-Muffler
11:1	353-508	1	Plug-HH	22	109-0296	1	Hose-Fuel
11:1:1	237-42	1	O-Ring	23	2412-98	2	Clamp-Hose
12	98-5975	4	Washer-Belleville	24	105-1853	1	Clamp-Hose
				30	95-4184	2	Screw-HHF

● Not serviced separately

▲ Use Pro-Lock, Nut Type (P/N 1-840022, .5ml tube) on threads.

■ Obtain parts from www.kawpowerepc.com

Deck Assembly

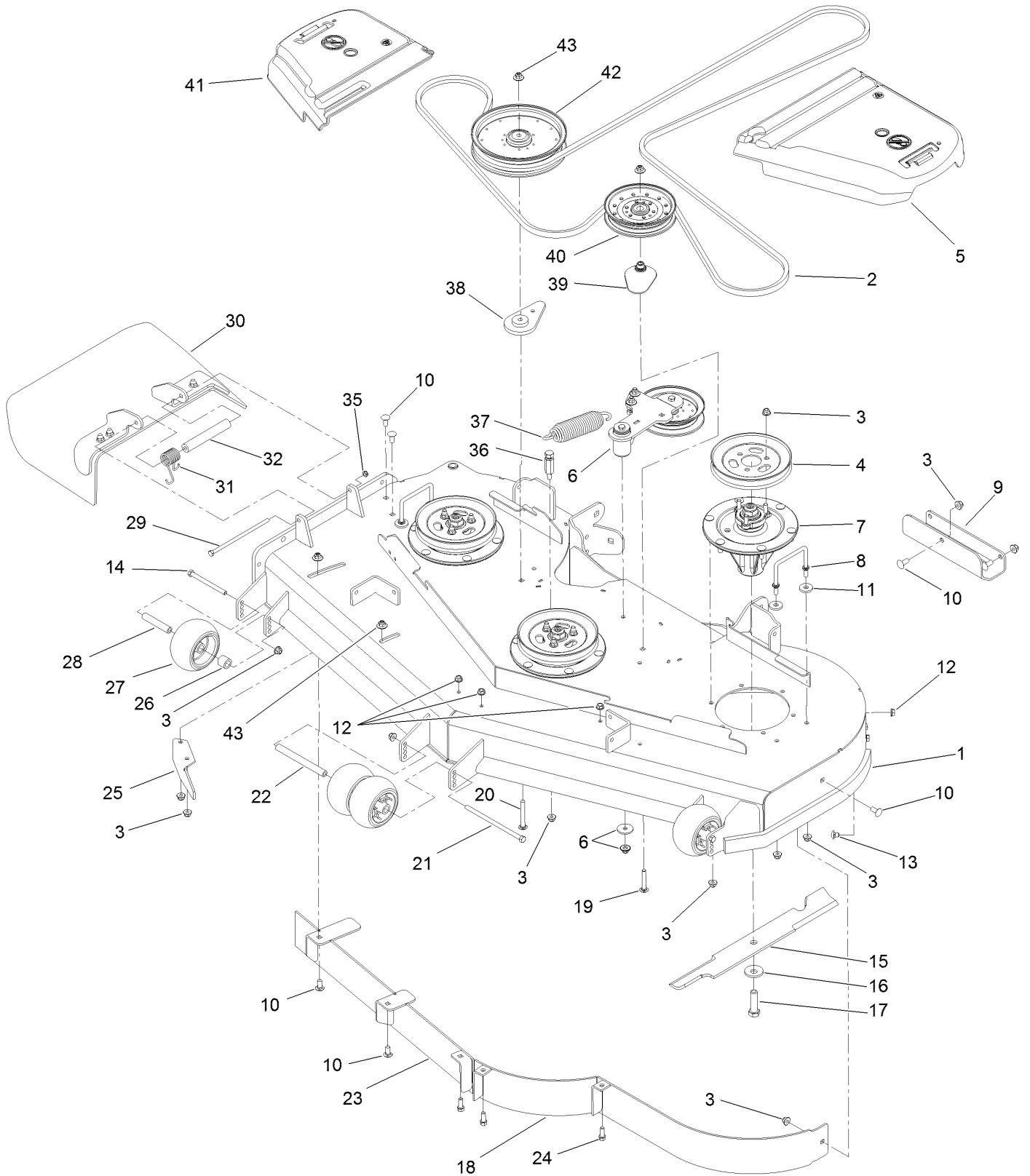

Deck Assembly (continued)

<i>Ref.</i>	<i>Part Number</i>	<i>Qty.</i>	<i>Description</i>	<i>Ref.</i>	<i>Part Number</i>	<i>Qty.</i>	<i>Description</i>
1	114-5815	1	Deck Decal ASM	22	98-5967	1	Spacer-Wheel
2	114-5858	1	Belt-V	23	115-7465-01	1	Baffle
3	104-8301	42	Nut-Flange, NI	24	92-1624	3	Screw-HWH
4	105-7734	3	Pulley	25	106-3216-01	1	Baffle-Discharge
5	109-6938	1	Cover-Belt, LH	26	98-7913	2	Tube-Spacer
6		1	Idler Arm ASM ●	27	1-603299	4	Roller-Scalp, Anti
7	119-8560	3	Spindle ASM	28	98-7912	2	Tube-Spanner
8	109-6982	2	Wireform-Cover	29	322-50	1	Screw-HH
9	121-8031-01	1	Plate-Skid	30	108-2792	1	Rubber Deflector ASM
10	3231-27	9	Screw-CARR	31	108-4052	1	Spring-Torsion
11	1-373034	4	Washer	32	105-4622	1	Spacer
12	3290-357	6	Nut-HHF, Whiz	35	3296-47	1	Nut-Lock, NI
13	108-5387	3	Screw-CARR	36	114-5867	1	Anchor-Spring, Tall
14	323-23	2	Screw-HH	37	116-6317	1	Spring-Extension
15	105-7718-03	3	Blade-Hi Flow	38	109-9416	1	Spacer-Idler
16	103-0865	3	Washer-Blade Bolt, Heavy	39	109-2872	1	Spacer-Pulley
17	51-4060	3	Screw-Blade	40	116-4670	1	Pulley-Idler, Flat
18	114-5842-01	1	Baffle	41	116-0094	1	Cover-Belt, RH
19	3231-40	1	Bolt-CARR, Short Neck	42	109-8590	1	Pulley-Idler
20	3231-42	1	Screw-CARR	43	109-6658	4	Nut-Flange, NI
21	108-5388	1	Screw-HH				

● Not serviced separately

Deck Decal Assembly No. 114-5815

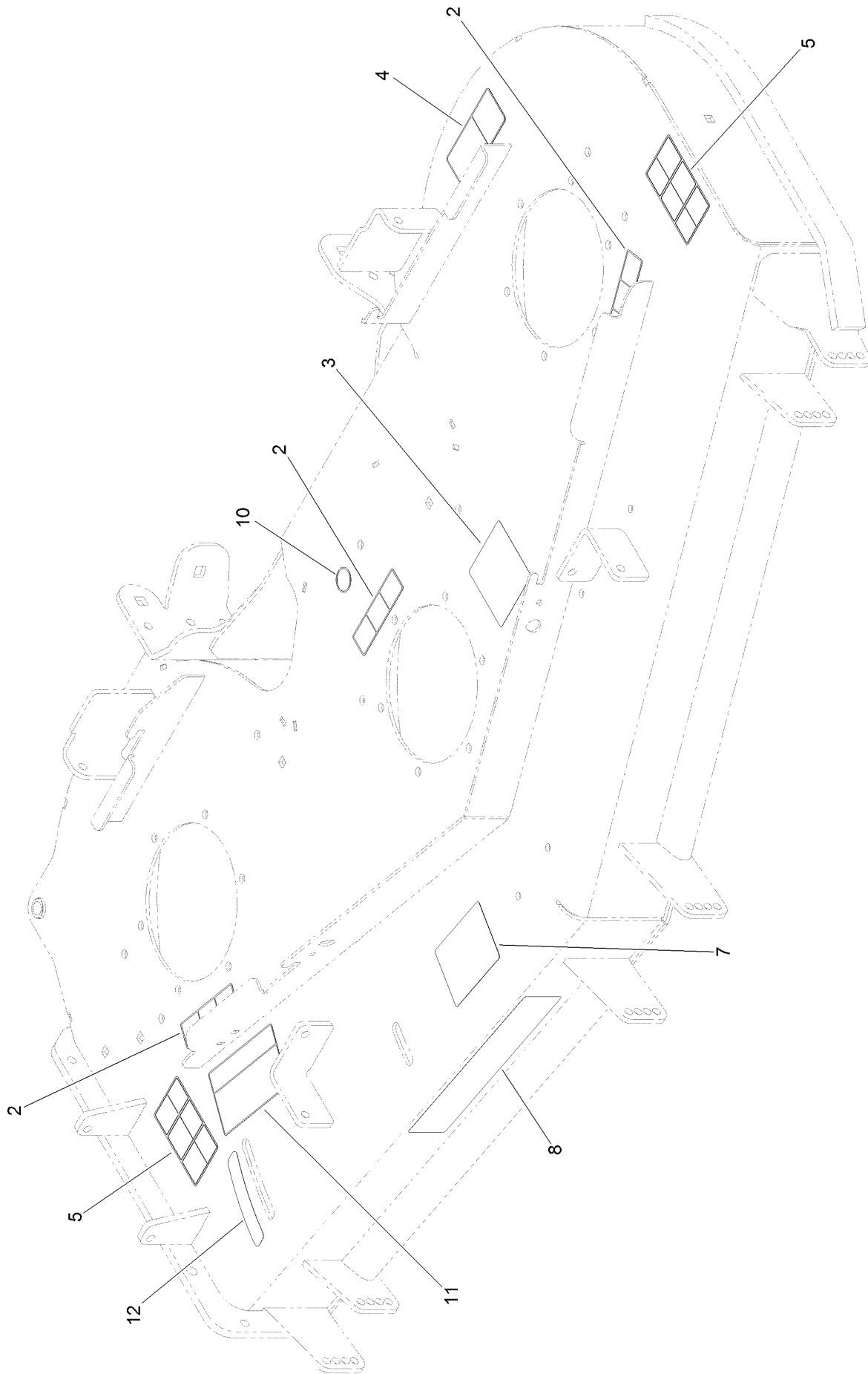

Deck Decal Assembly No. 114-5815 (continued)

<i>Ref.</i>	<i>Part Number</i>	<i>Qty.</i>	<i>Description</i>	<i>Ref.</i>	<i>Part Number</i>	<i>Qty.</i>	<i>Description</i>
2	112-9028	3	Decal-Missing, Cover	8	107-1619	1	Decal
3	115-7445	1	Decal-Routing, Deck Belt	10	58-6520	1	Decal-Grease
4	93-7818	1	Decal-Torque, Blade Bolt	11	110-2068	1	Decal-Adjustment, Baffle
5	117-3848	2	Decal-Danger	12	110-2067	1	Decal-Setting, Baffle
7	127-0326	1	Decal-Anti Scalp				

Idler Assembly

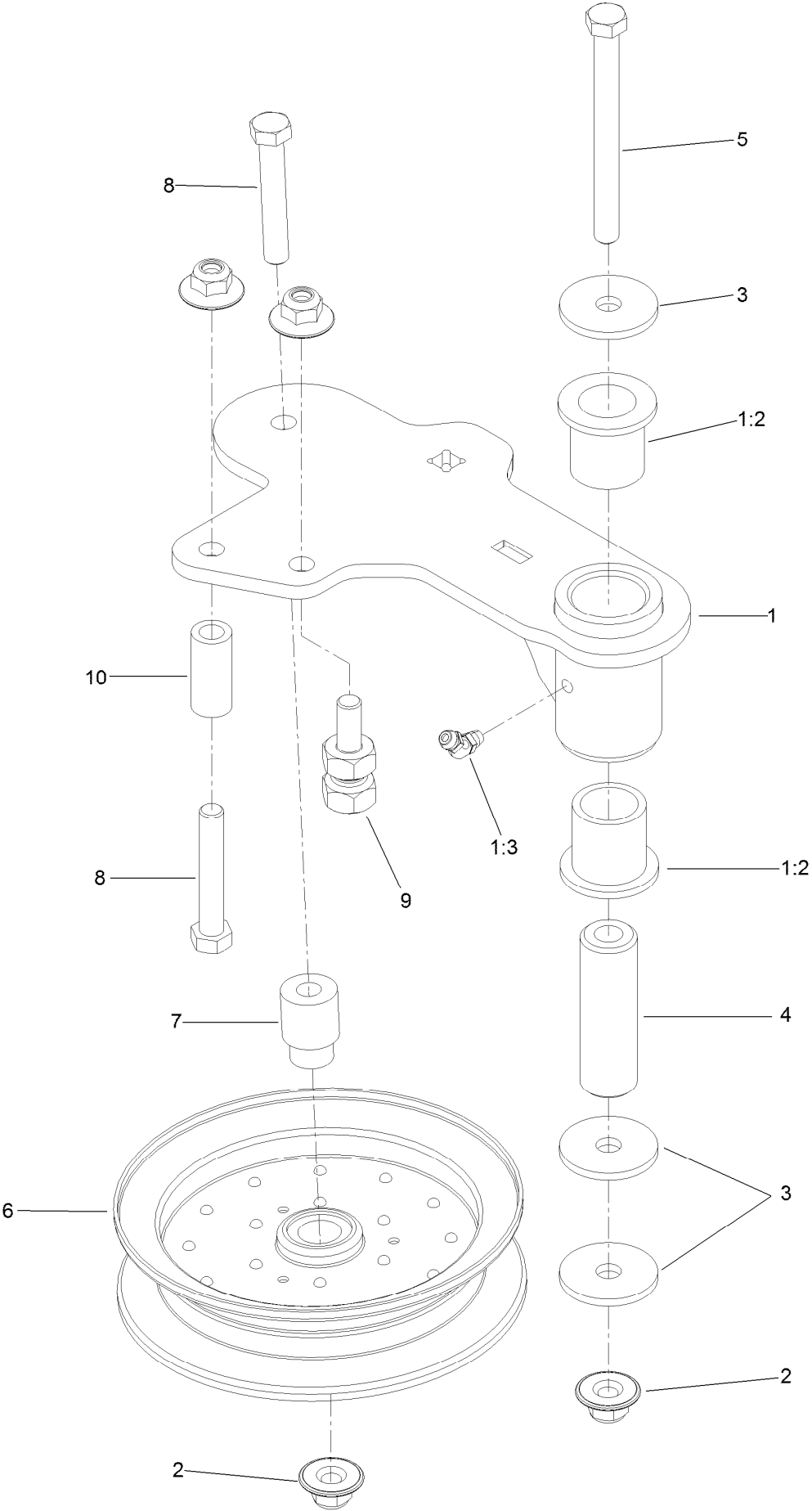

Idler Assembly (continued)

<i>Ref.</i>	<i>Part Number</i>	<i>Qty.</i>	<i>Description</i>	<i>Ref.</i>	<i>Part Number</i>	<i>Qty.</i>	<i>Description</i>
1	114-5870	1	Idler Arm ASM	5	98-5961	1	Screw-HH
1:2	1-303514	2	Bearing-Flanged	6	116-4668	1	Idler-Pulley, Flanged
1:3	1481	1	Fitting-Grease	7	112-4212	1	Mount-Pulley
2	109-6658	4	Nut-Flange, NI	8	323-11	2	Screw-HH
3	1-213069	3	Washer	9	114-5866	1	Anchor-Spring, Short
4	114-5848	1	Spacer-Plain	10	104-0151	1	Spacer

Spindle Assembly No. 119-8560

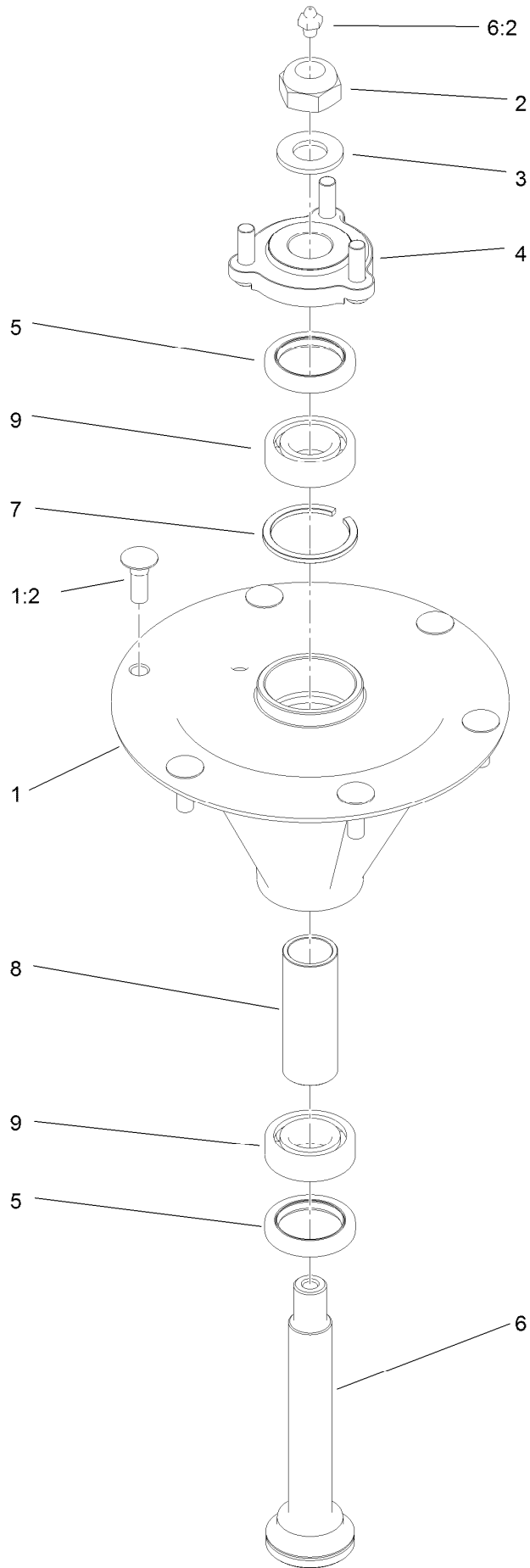

Spindle Assembly No. 119-8560 (continued)

<i>Ref.</i>	<i>Part Number</i>	<i>Qty.</i>	<i>Description</i>	<i>Ref.</i>	<i>Part Number</i>	<i>Qty.</i>	<i>Description</i>
1		1	Spindle Housing And Studs ASM ●	5	253-133	2	Seal-Oil
1:2	114-8195	6	Bolt-Ribbed Neck	6	119-8527	1	Shaft-Spindle
2	3296-67	1	Nut-Lock, NI	6:2	302-2	1	Fitting-Grease
3	92-5836	1	Washer	7	119-8532	1	Snap Ring
4	117-6172	1	Spindle Hub ASM	8	117-6184	1	Spacer
				9	119-8558	2	Bearing-Noseal

● Not serviced separately

Rubber Deflector Assembly No. 108-2792

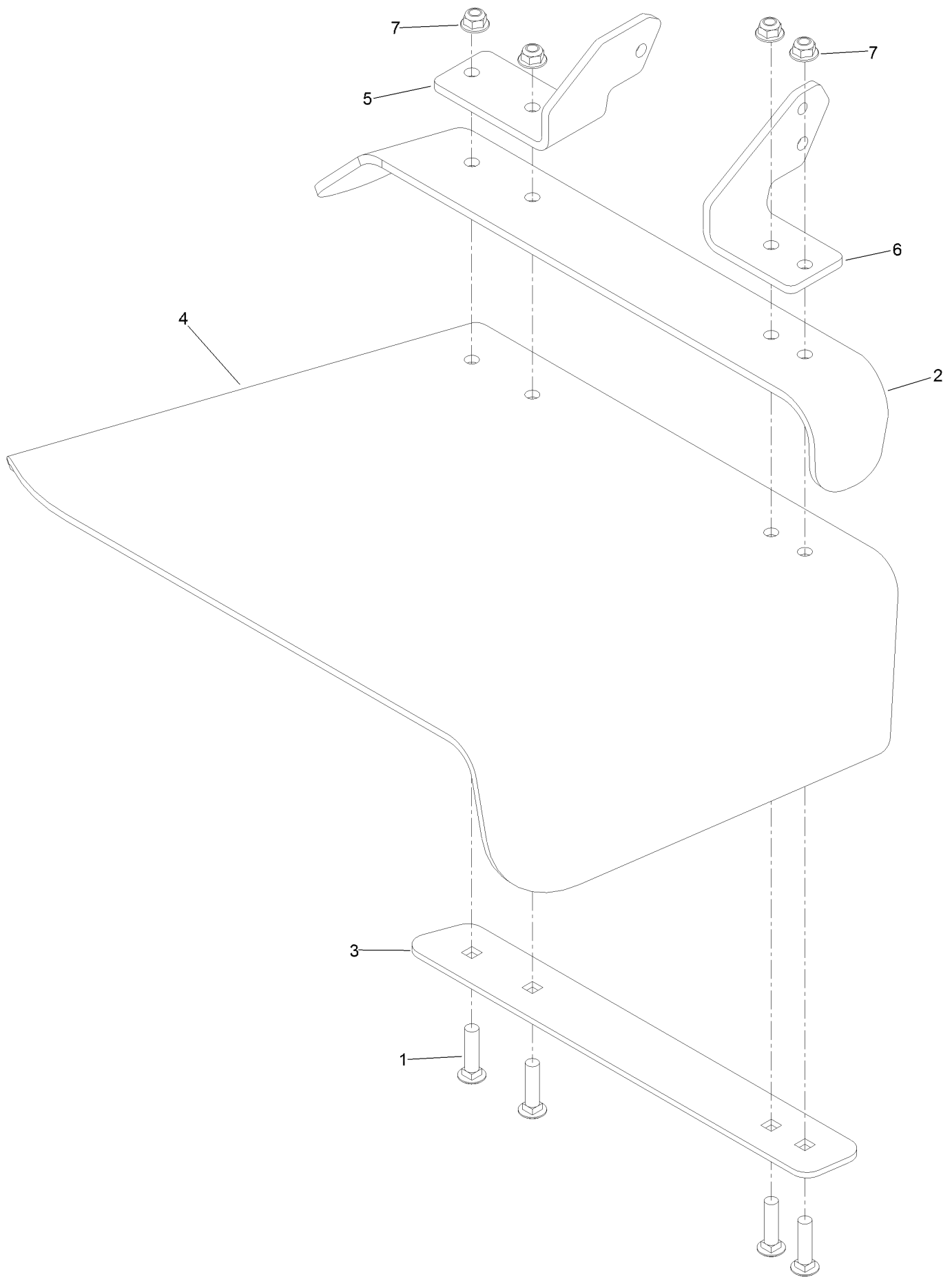

Rubber Deflector Assembly No. 108-2792 (continued)

<i>Ref.</i>	<i>Part Number</i>	<i>Qty.</i>	<i>Description</i>	<i>Ref.</i>	<i>Part Number</i>	<i>Qty.</i>	<i>Description</i>
1	3231-4	4	Screw-CARR	5	108-4059-01	1	Plate-Hinge, Rear
2	106-3246-01	1	Deflector	6	106-3253-01	1	Plate-Hinge, Front
3	106-3248-03	1	Strap-Discharge	7	104-8301	4	Nut-Flange, NI
4	108-5029	1	Deflector-Rubber				

Seat Mount Assembly

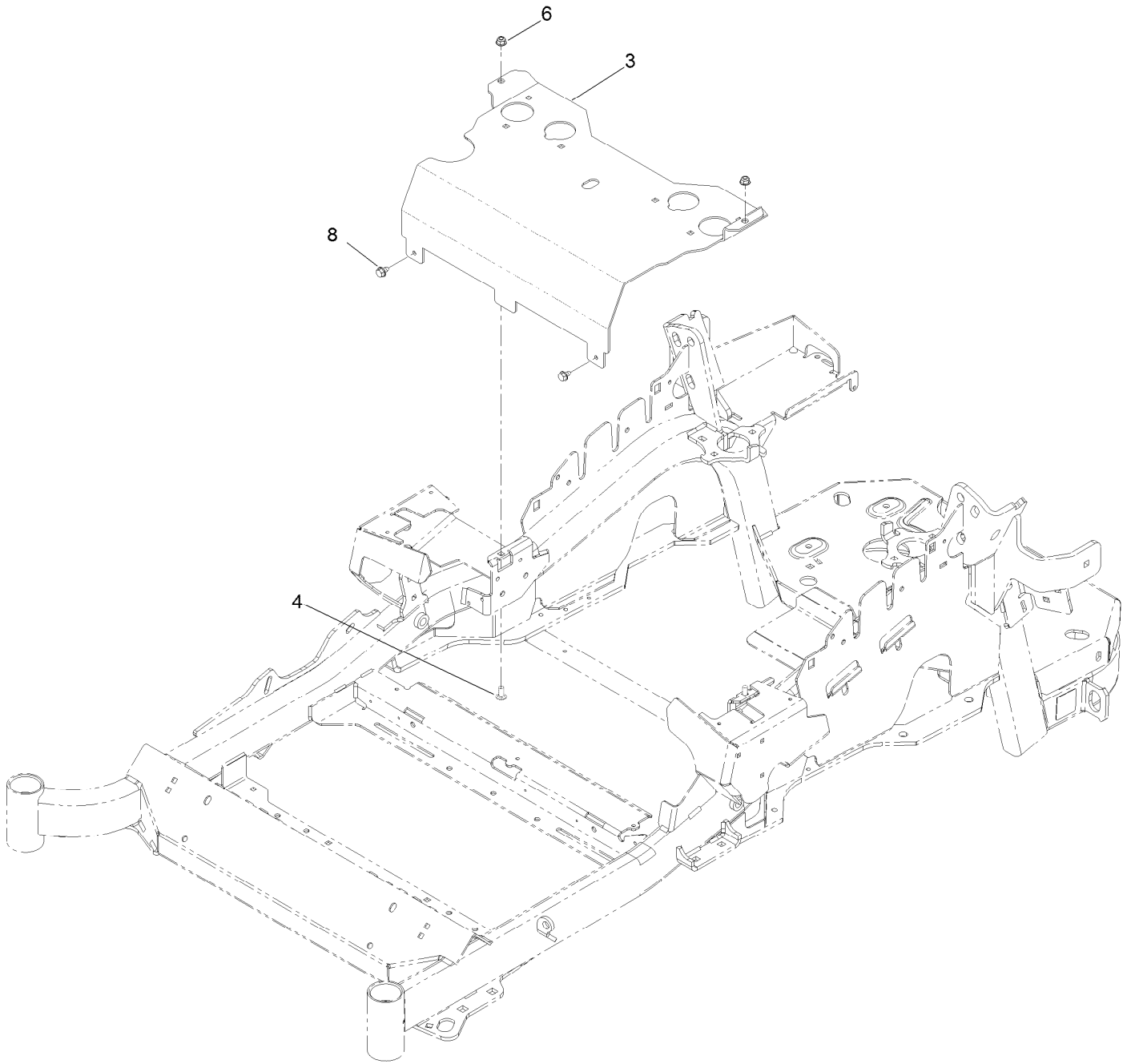

Seat Mount Assembly (continued)

<i>Ref.</i>	<i>Part Number</i>	<i>Qty.</i>	<i>Description</i>	<i>Ref.</i>	<i>Part Number</i>	<i>Qty.</i>	<i>Description</i>
3	116-2130-03	1	Panel-Front, Seat Mount	6	104-8300	2	Nut-Flange, NI
4	3230-23	2	Screw-CARR	8	9266934	2	Screw

Suspension Platform Assembly

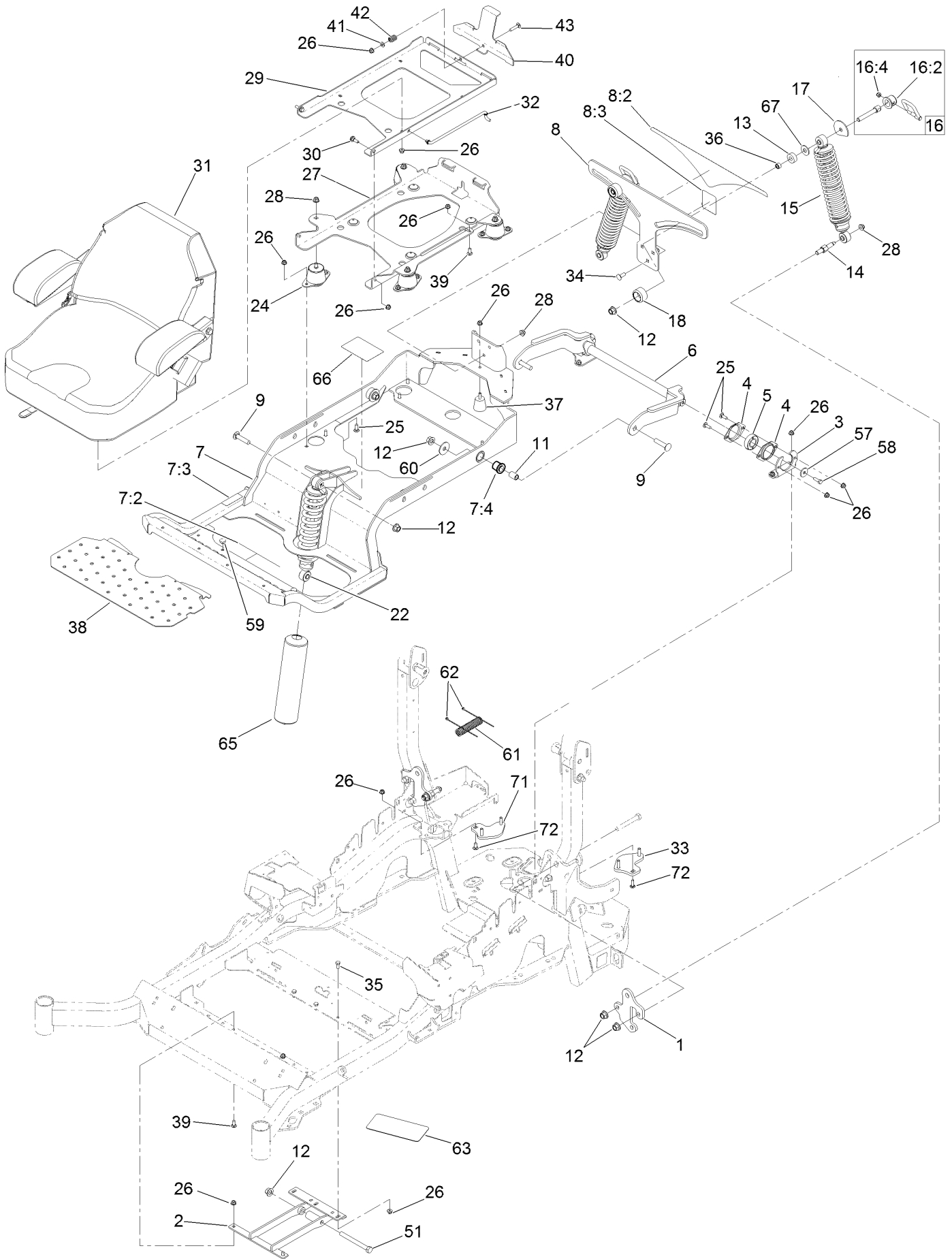

Suspension Platform Assembly (continued)

<i>Ref.</i>	<i>Part Number</i>	<i>Qty.</i>	<i>Description</i>	<i>Ref.</i>	<i>Part Number</i>	<i>Qty.</i>	<i>Description</i>
1	131-6333-01	2	Plate-Mount, Shock	28	104-8301	9	Nut-Flange, NI
2	131-6327-01	1	Mount-Lower	29	116-3859-03	1	Plate-Frame, Seat
3	127-6759-03	2	Bracket-Bearing	30	116-1297	2	Screw-Shoulder
4	127-6743	4	Housing-Bearing, Flange	31	116-0035	1	Seat-Standard
5	1-653346	2	Bearing	32	116-0070	1	Rod-Prop
6	127-6754-03	1	Arm-Trailing	33	127-6766	1	LH Plate ASM (W/Studs)
7	132-5057	1	Subframe ASM	34	3231-22	3	Screw-CARR
7:2	132-0871	1	Decal-Danger	35	322-3	3	Screw-HH
7:3	115-9625	1	Decal-Brake, Parking	36	47-7270	2	Bearing-Needle
7:4	127-6745	2	Bushing-Flange	37	132-5058	1	Bumper-Rubber
8	133-1808	1	Bracket-Mounting	38	132-5089-01	1	Floorpan
8:2	132-5067	1	Decal-Adjustment, Ride	39	3230-23	3	Screw-CARR
8:3	132-5063	1	Decal-Lock, Cam	40	132-5088-03	1	Plate-Latch, Seat
9	127-6768	3	Screw-CARR	41	3256-23	1	Washer-Flat
11	127-6751	2	Spacer-Aluminum	42	107-3017	1	Spring-Compression
12	99-5107	8	Nut-Lock	43	3230-4	1	Screw-CARR
13	131-8801	2	Spacer	51	325-19	1	Screw-HH
14	131-6348	2	Bolt-Shoulder	57	105-3048	2	Washer-Flat
15	131-8827	2	Shock-Spring	58	116-0648	2	Screw-HH, Thread Locking
16	131-8843	2	Cam Lock ASM	59	1-513658	2	Bumper
16:2	107-1644	1	Cap-Lock	60	86-1990	2	Washer-Thrust
16:4	119-4038	1	Nut-Hex, NI	61	131-8846	1	Cover-Hose
17	131-4646	2	Plate-Stop	62	1-303287	2	Tie-Cable
18	131-4647	2	Knob-Front	63	131-8835	1	Tread-Grip
22	131-8829	1	Shock-Spring	65	132-5068	1	Cover-Shock
24	109-9034	4	Isolator-Seat	66	125-9383	1	Decal-Service Aid
25	3230-10	12	Screw-CARR	67	3256-6	2	Washer-Flat
26	104-8300	32	Nut-Flange, NI	71	127-6765	1	RH Plate ASM (W/Studs)
27	131-6324-03	1	Plate-Support, Iso Seat	72	3230-22	2	Screw-CARR

Seat Assembly No. 116-0035

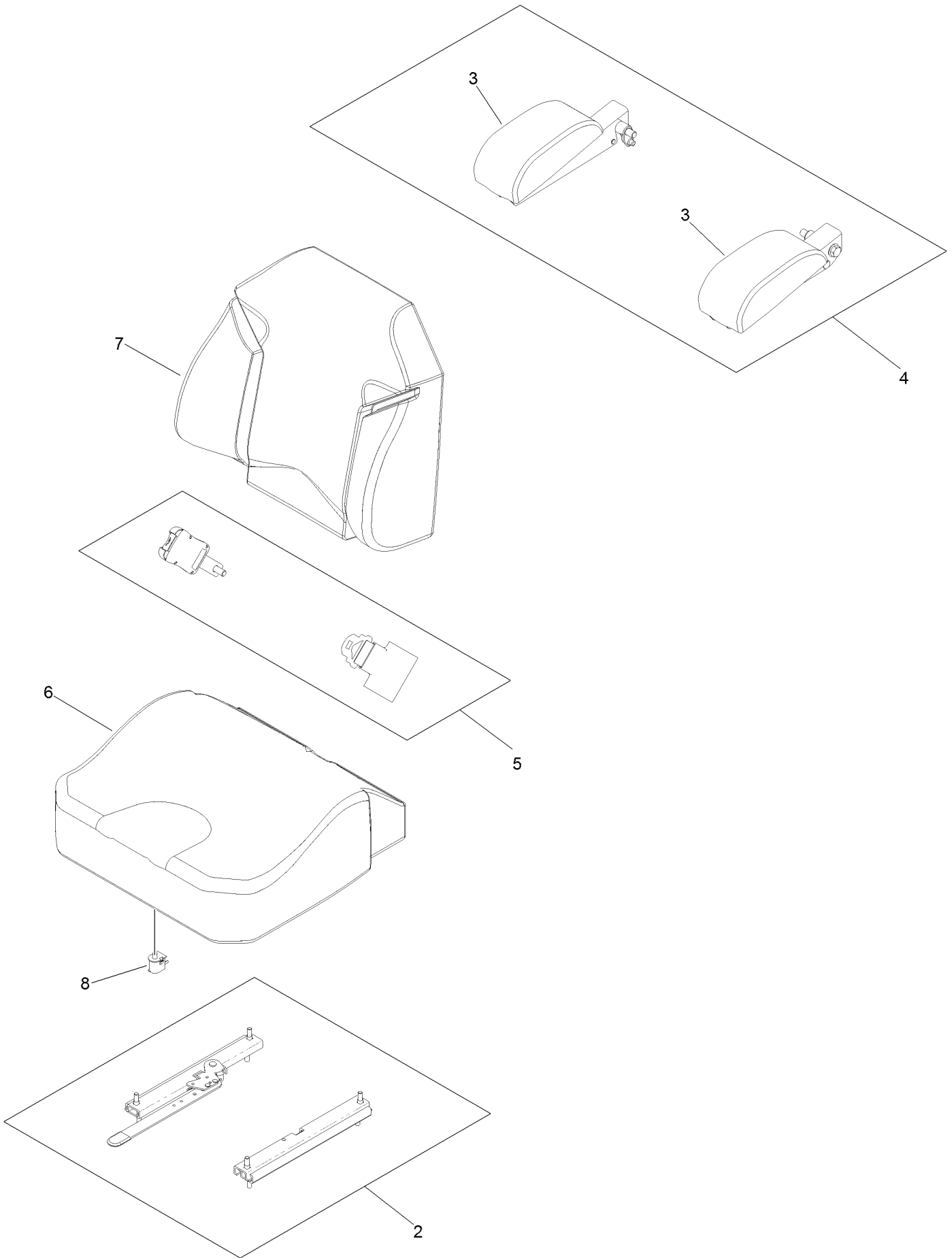

Seat Assembly No. 116-0035 (continued)

<i>Ref.</i>	<i>Part Number</i>	<i>Qty.</i>	<i>Description</i>	<i>Ref.</i>	<i>Part Number</i>	<i>Qty.</i>	<i>Description</i>
2	109-9801	1	Seat Track Set	6	109-9806	1	Cover-Cushion
3	109-9802	1	Arm Rest Pad Set	7	109-9808	1	Cover-Back
4	109-9803	1	Arm Rest Set	8	82-2190	1	Switch-Bail
5	109-9805	1	Seat Belt Kit				

Suspension Platform Rubber Mat Assembly

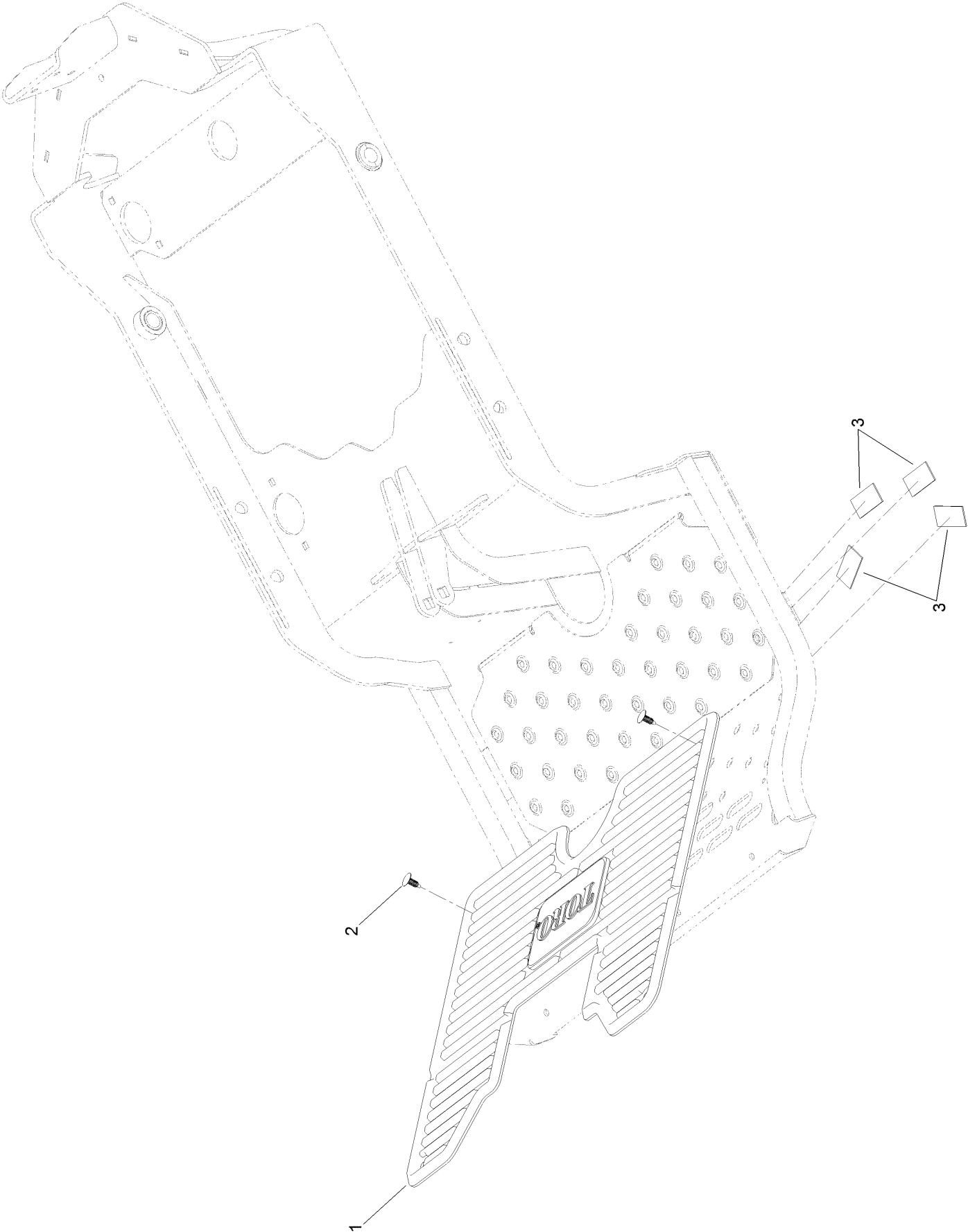

Suspension Platform Rubber Mat Assembly (continued)

<i>Ref.</i>	<i>Part Number</i>	<i>Qty.</i>	<i>Description</i>
1	133-1810	1	Mat-Floor
2	117-2382	2	Plug-Plastic
3	130-0733	4	Pad-Rubber

Attachments and Accessories

For 74996 Z Master Commercial 3000 Series Riding Mower with 60in TURBO FORCE Side Discharge Mower

Product Name	Model/Part
Blade-Mid Flow, 20.5in	105-7715-03
Blade-Lo Flow, 20.5in	105-7716-03
Blade-Hi Flow, 20.5in.....	105-7718-03
Blade-Recycler, 20.5in.....	105-7777-03
Blade-Atomic, 20.5in	105-8777-03
Turbo Baffle Kit	107-1634
6 Pack Blade, 20.5in Hi-Flow	108-1114
6 Pack-Blade, 20.5in Atomic.....	108-1115
6 Pack Blade, 20.5in Mid-Flow	108-1123
6 Pack-Blade, 20.5in Lo Flow	108-1128
Anti-Scalp Kit (Trim Side).....	108-4140
Hitch Kit	109-9487
6 Pack-Blade, 20.5in Recycler.....	110-0405
Hypr-Oil 500 (quart).....	114-4713
Hypr-Oil 500 (gallon).....	114-4714
Hypr-Oil 500-5 (5 gallon).....	114-4715
Bimini Folding Shade Assembly	115-4510
Recycler Kit	115-7468
Roller Striper Kit.....	115-7470
Light Kit.....	116-1154
Operator Controlled Discharge Chute Kit.....	117-3600
MVP Belt and Blade Kit.....	127-1636
Spanner Wrench.....	132-5069
Toro Rider Over Seat Bag	490-7317
Toro Deluxe Rider Cover.....	490-7319
Toro Rider Arm Rest Bag	490-7320
Spark Arrestor Screen	75-6880
Blower and Drive Kit	78553
E-Z Vac Triple Bagging System	78563
E-Z Vac DFS Collection System	78567
Filter Minder Gauge	99-4664
Trash Holder Kit.....	TC26

Notes:



Count on it.