



Count on it.

Operator's Manual

Pro Sneak 365 Vibratory Plow

Model No. 25403—Serial No. 316000001 and Up

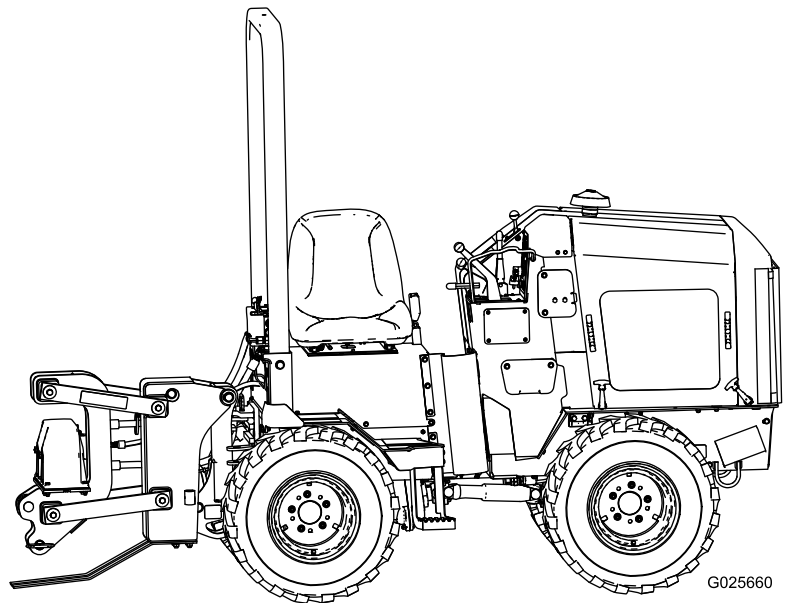

G025660



⚠ WARNING

CALIFORNIA Proposition 65 Warning

This product contains a chemical or chemicals known to the State of California to cause cancer, birth defects, or reproductive harm.

Diesel engine exhaust and some of its constituents are known to the State of California to cause cancer, birth defects, and other reproductive harm.

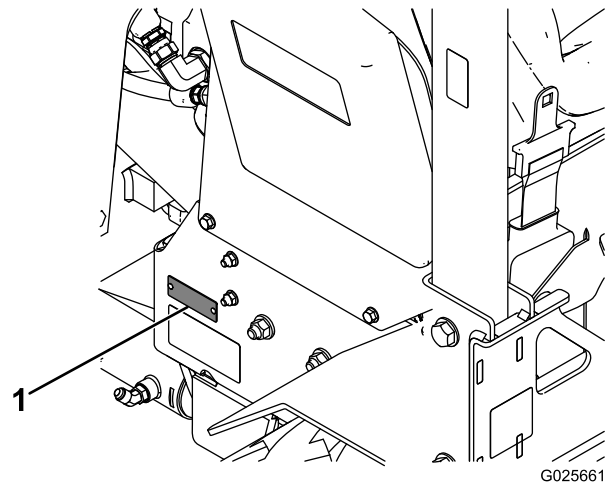

Figure 1

1. Model and serial number location

Model No. _____

Serial No. _____

This manual identifies potential hazards and has safety messages identified by the safety-alert symbol (Figure 2), which signals a hazard that may cause serious injury or death if you do not follow the recommended precautions.



Figure 2

1. Safety-alert symbol

This manual uses 2 words to highlight information.

Important calls attention to special mechanical information and **Note** emphasizes general information worthy of special attention.

Introduction

Read this information carefully to learn how to operate and maintain your product properly and to avoid injury and product damage. You are responsible for operating the product properly and safely.

You may contact Toro directly at www.Toro.com for product safety and operation training materials, accessory information, help finding a dealer, or to register your product.

Whenever you need service, genuine Toro parts, or additional information, contact an Authorized Service Dealer or Toro Customer Service and have the model and serial numbers of your product ready. Figure 1 identifies the location of the model and serial numbers on the product. Write the numbers in the space provided.

Keep the manual with the machine.

Contents

Safety	4
Safe Operating Practices.....	4
Safety and Instructional Decals	7
Product Overview	13
Controls	13
Specifications	15
Attachments/Accessories.....	15
Operation	16
Think Safety First.....	16
Adding Fuel.....	16
Filling the Fuel Tank	17
Starting and Shutting Off the Engine.....	17
Operating the Vibratory Plow	18
Rotating the Wheels.....	19
Checking the Interlock System	20
Transporting the Machine.....	20
Maintenance	22
Recommended Maintenance Schedule(s)	22
Pre-maintenance Procedures	23
Opening the Hood	23
Lubrication	23
Greasing the Machine	23
Engine Maintenance	24
Servicing the Air Cleaner.....	24
Servicing the Engine Oil.....	25
Servicing the Diesel Particulate Filter (DPF)	27
Fuel System Maintenance	27
Checking the Fuel Lines and Connections	27
Draining the Fuel Filter/Water Separator.....	27
Replacing the Fuel Filter Canister.....	28
Draining the Fuel Tank	28
Electrical System Maintenance	28
Servicing the Battery.....	28
Drive System Maintenance	29
Servicing the Tires.....	29
Servicing the Transmission and Axles	30
Cooling System Maintenance	31
Servicing the Cooling System	31
Belt Maintenance	32
Checking the Alternator Drive Belt Tension	32
Replacing the Drive Belt.....	33
Controls System Maintenance	33
Checking the Parking Brake	33
Adjusting the Traction Drive for Neutral.....	33
Cleaning the Directional Controls Linkage Assembly.....	34
Hydraulic System Maintenance	34
Servicing the Hydraulic System.....	34
ROPS Maintenance	38
Checking and Servicing the ROPS.....	38
Cleaning	39
Removing Debris from the Machine.....	39
Cleaning the Chassis	39
Storage	39

Safety

This machine has been designed in accordance with ANSI B71.4

Improper use or maintenance by the operator or owner can result in injury. To reduce the potential for injury, comply with these safety instructions and always pay attention to the safety alert symbol , which means: *Caution, Warning, or Danger*—personal safety instruction. Failure to comply with the instruction may result in personal injury or death.

Safe Operating Practices

This product is capable of amputating hands and feet. Always follow all safety instructions to avoid serious injury or death.

WARNING

Engine exhaust contains carbon monoxide, an odorless, deadly poison that can kill you.

Do not run the engine indoors or in an enclosed area.

Training

- Read the *Operator's Manual* and other training material. If the operator(s) or mechanic(s) cannot read English, it is the owner's responsibility to explain this material to them.
- Become familiar with the safe operation of the equipment, operator controls, and safety signs.
- All operators and mechanics should be trained. The owner is responsible for training the users.
- Never let children or untrained people operate or service the equipment. Local regulations may restrict the age of the operator.
- The owner/user can prevent and is responsible for accidents or injuries occurring to people, or damage to property.

Preparation

- Evaluate the terrain to determine what accessories and attachments are needed to properly and safely perform the job. Only use accessories and attachments approved by the manufacturer.
- Wear appropriate clothing including hard hat, safety glasses, long pants, substantial slip-resistant safety shoes, reflector vests, respirators, and hearing protection. Tie back long hair and do not wear loose clothing or jewelry.
- Inspect the area where the equipment is to be used.
 - **Before digging, have the area marked for underground utilities, and do not dig in marked areas.**
 - Remove all objects such as rocks, toys, and wire which can be thrown by the machine.

- Ensure that the area is clear of people and stop the machine if anyone enters the area.
- Watch for holes, ruts terrain could overturn the machine. Tall grass can hide obstacles.
- Use extra care when handling fuels. They are flammable and vapors are explosive.
 - Use only an approved container
 - Never remove the fuel cap or add fuel with the engine running. Allow the engine to cool before refueling. Do not smoke.
 - Never refuel or drain the machine indoors.
 - Never store the machine or fuel container inside where there is an open flame, such as near a water heater or furnace.
 - Keep container nozzle in contact with the tank during filling
- Know the hand signals used on your job. Follow the instructions of the flagmen, signals, etc.
- Check that the operator's presence controls, safety switches, and shields are attached and functioning properly. Do not operate unless they are functioning properly.

Operation

- Before starting each day, check the machine for oil or fluid leaks. Replace all damaged, loose, worn or missing parts and follow the lubrication and maintenance procedures shown in this manual.
- Never run an engine in an enclosed area.
- Locate the pinch point areas marked on the machine and attachments and keep hands and feet away from these areas.
- Only operate in good light, keeping away from holes and hidden hazards.
- Never operate without the guards securely in place. Be sure all interlocks are attached, adjusted properly, and functioning properly.
- Do not operate the machine when tired, ill, or under the influence of alcohol or drugs.
- Use care when loading or unloading the machine into a trailer or truck.
- Never carry passengers and keep pets and bystanders away.
- Never allow anyone in the trench while operating the machine.
- Be sure all drives are in neutral and parking brake is engaged before starting the engine. Start the engine only from the operator's position.
- Never jerk the controls; use a steady motion.
- Look behind and down before backing up to be sure of a clear path.

- Allow adequate space when turning this unit.
- Slow down, watch for traffic, and use caution when operating near or crossing roadways and sidewalks.
- Use care when approaching blind corners, shrubs, trees, or other objects that may obscure vision.
- Ensure that you operate the machine in areas where there are no obstacles in close proximity to the operator. Failure to maintain adequate distance from trees, walls, and other barriers may result in injury as the machine backs up during operation if the operator is not attentive to the surroundings. Only operate the unit in areas where there is sufficient clearance for the operator to safely maneuver the product.
- Check for overhead clearances (i.e. branches, doorways, electrical wires) before driving under any objects and do not contact them.
- Do not touch parts which may be hot from operation. Allow them to cool before attempting to maintain, adjust, or service.
- Never leave a running machine unattended.
- Stop on level ground, lower the attachments, set the parking brake, disengage the auxiliary hydraulics, shut off the engine and remove the key before leaving the operator's position for any reason.
- Use only Toro-approved attachments.
 - Read all attachment manuals.
 - Attachments can change the stability and the operating characteristics of the machine.
 - The warranty may be voided if used with unapproved attachments.
 - Ensure that the attachment is properly installed.
 - Keep hands and feet away from moving attachments.
- Lightning can cause severe injury or death. If lightning is seen or thunder is heard in the area, do not operate the machine; seek shelter.
 - Use caution when working on newly disturbed earth.
 - Keep all movements on slopes slow and gradual. Do not make sudden changes in speed or direction.
 - Avoid starting or stopping on a slope. If the machine loses traction, proceed gradually, straight down the slope.
- Do not operate near drop-offs, ditches, or embankments. The machine could suddenly turn over if a wheel goes over the edge of a cliff or ditch, or if an edge caves in.
- Do not operate on wet grass. Reduced traction could cause sliding.
- Only operate the machine on level ground when the machine is in the narrow wheel configuration. If you must operate the machine on a slope, put the machine in wide wheel configuration.

Rollover Protection Structure (ROPS) System

- Before operating a machine with a ROPS (rollover protection structure), ensure that the seat belt is in good condition and is securely attached to the machine.
- Always wear a seat belt when operating a machine with a ROPS.
- Inspect the ROPS at the interval recommended in this manual or when the ROPS has been in an accident.
- Repair a damaged ROPS using only genuine Toro replacement parts; do not repair or modify the ROPS.
- Check carefully for overhead clearances (i.e. branches, doorways, electrical wires) before driving under any objects and do not contact them.
- Do not remove the ROPS except when servicing or replacing it.
- Do not add weight to the machine that exceeds the gross weight displayed on the ROPS label.

Slope Operation

Slopes are a major factor related to loss-of-control and tip-over accidents, which can result in severe injury or death. All slopes require extra caution.

- **Avoid operating this machine on slopes.**
- Do not park the machine on a hillside or slope without lowering the attachment to the ground, setting the parking brake, and chocking the wheels. If the machine loses traction, proceed gradually, straight down the slope.
- Avoid turning on slopes.
 - If you must turn, turn slowly and keep the heavy end of the machine uphill.
 - Slow down and use caution when on hillsides, making turns, or changing directions on slopes.
 - Ground conditions may adversely affect the stability of the machine.

Maintenance and Storage

- Never tamper with safety devices.
- Park the machine on level ground. Never allow untrained personnel to service the machine.
- Keep hands and feet away from moving parts. If possible, do not make adjustments with the engine running.
- Use jack stands to support components when required.
- Keep the machine and attachments free of grass, leaves, or other debris build-up. Clean up oil or fuel spillage. Allow the machine to cool before storing.
- Keep the equipment and all parts in good working condition and all hardware tightened. Replace all worn or damaged decals.
- Disconnect the battery before making any repairs. Disconnect the negative terminal first and the positive last. Reconnect positive first and negative last.

- Battery acid is poisonous and can cause burns. Avoid contact with skin, eyes, and clothing. Protect your face, eyes, and clothing when working with a battery.
- Battery gases can explode. Keep cigarettes, sparks and flames away from the battery.
- Charge batteries in an open well ventilated area, away from spark and flames. Unplug the charger before connecting or disconnecting it from the battery. Wear protective clothing and use insulated tools.
- Keep your body and hands away from pin hole leaks or nozzles that eject high pressure hydraulic fluid. Use cardboard or paper to find hydraulic leaks; never use your hands. Hydraulic fluid escaping under pressure can penetrate skin and cause an injury requiring surgery within a few hours by a qualified surgeon; otherwise gangrene may result.
- Disengage the auxiliary hydraulics, lower the attachment, set the parking brake, shut off the engine, and remove the key. Wait for all movement to stop before adjusting, cleaning, or repairing.
- Carefully release pressure from components with stored energy.
- Let the engine cool before storing and do not store near flame.
- Do not store fuel near flames or drain indoors.
- Stop and inspect the equipment if you strike an object. Make any necessary repairs before starting the machine.
- Use only genuine Toro replacement parts to ensure that original standards are maintained.

Danger Zone

The danger zone is the area within and around the machine where a person is exposed to the risk of injury. This proximity includes where a person is reachable by operational movement of the machine, its working devices, auxiliary equipment, or swinging/falling equipment. The following illustration displays the safe distance required by all individuals.

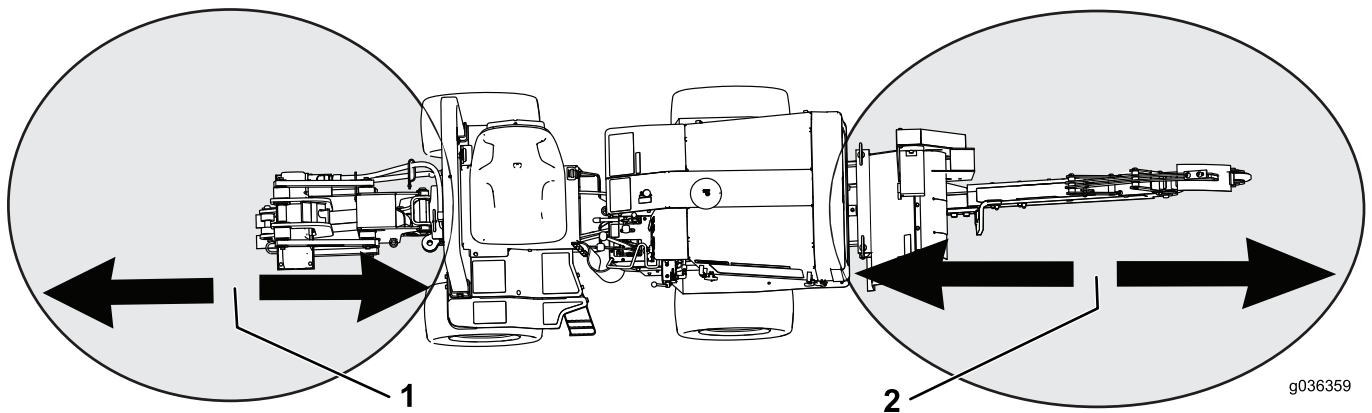

Figure 3

1. 1.8 M (6 ft) safety distance

2. 3 M (10 ft) safety distance

Safety and Instructional Decals



Safety decals and instructions are easily visible to the operator and are located near any area of potential danger. Replace any decal that is damaged or lost.

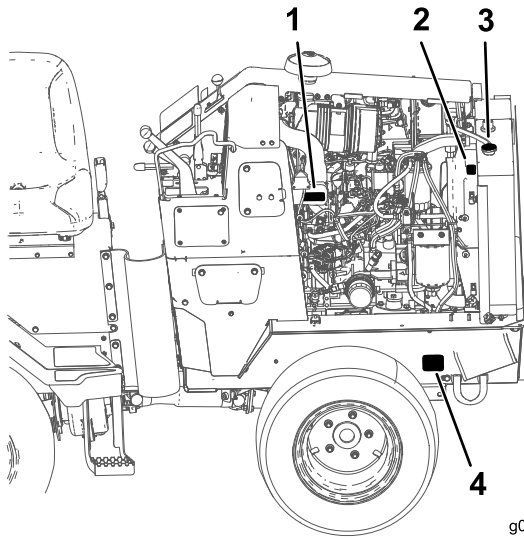

g037431

Figure 4

- | | |
|---|---|
| 1. Decal 125-6688 | 3. Decal 106-6755 |
| 2. Decal 120-0627 (both sides of the machine) | 4. Decal 125-6694 (both sides of the machine) |

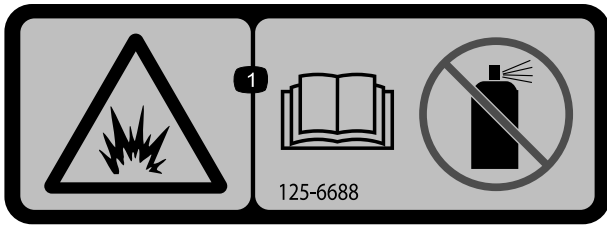

125-6688

1. Explosion hazard—Read the *Operator's Manual*; Do not use starting fluid.

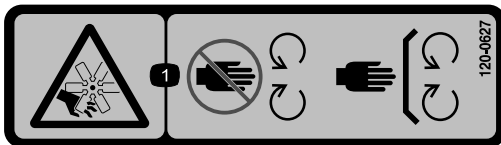

120-0627

1. Cutting/dismemberment hazard, fan—stay away from moving parts, keep all guards and shields in place.

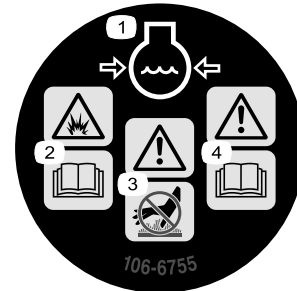

106-6755

- | | |
|---|--|
| 1. Engine coolant under pressure | 3. Warning—do not touch the hot surface. |
| 2. Explosion hazard—read the <i>Operator's Manual</i> . | 4. Warning—read the <i>Operator's Manual</i> . |

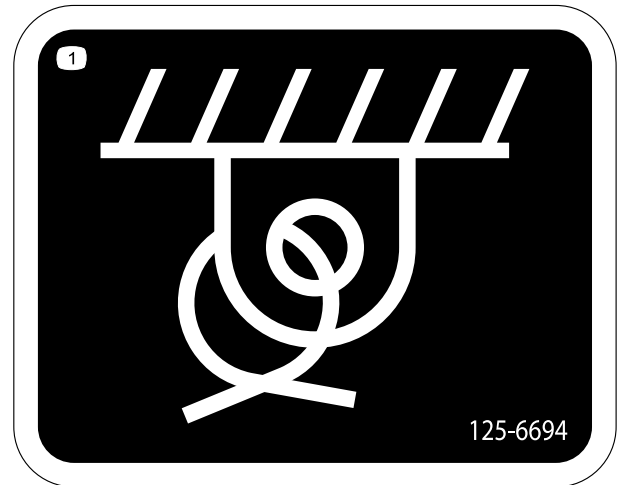

125-6694

125-6694

1. Tie-down location

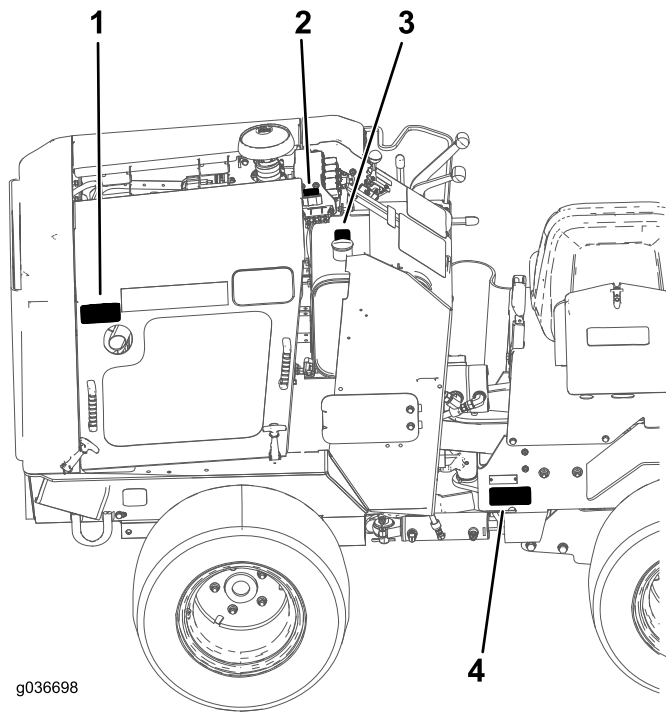

g036698

Figure 5

- 1. Decal 125-4963
- 2. Decal 130-4291
- 3. Decal 125-8483
- 4. Decal 125-6672



125-4963

- 1. Warning—keep hands away from hot surfaces

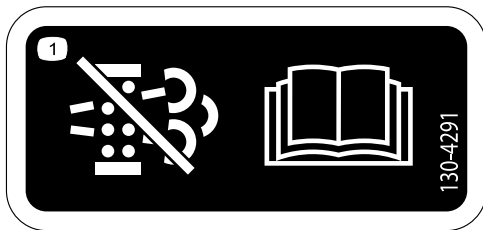

130-4291

- 1. Regeneration inhibit—read the *Operator's Manual*.

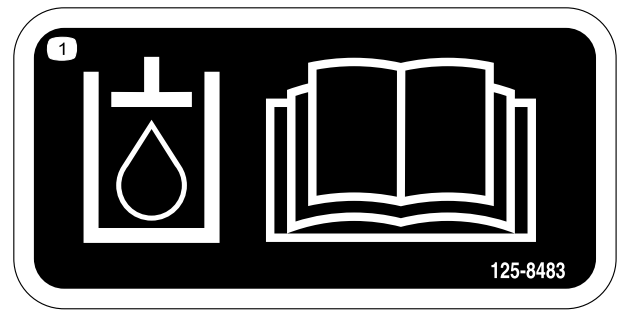

125-8483

- 1. Hydraulic fluid; read the *Operator's Manual*.



125-6672

- 1. Crushing hazard—stay away from articulated joints.

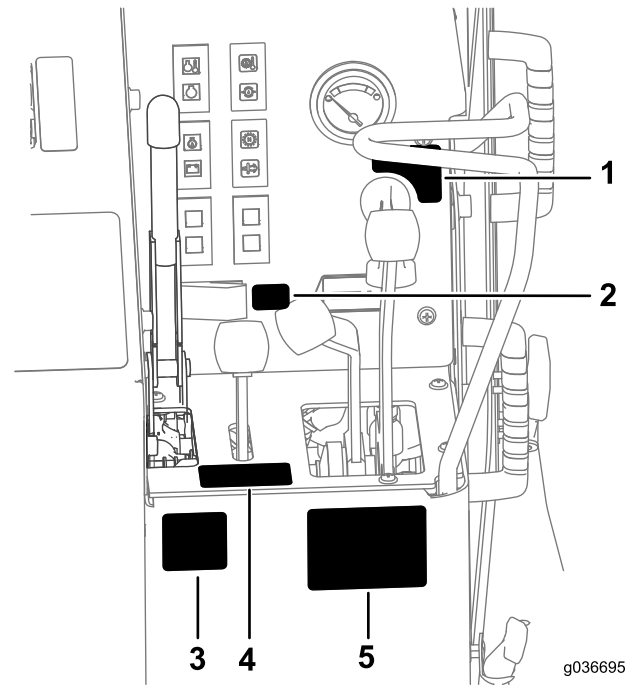

g036695

Figure 6

- 1. Decal 130-7360
- 2. Decal 130-4341
- 3. Decal 125-6674
- 4. Decal 130-7361
- 5. Decal 125-6680

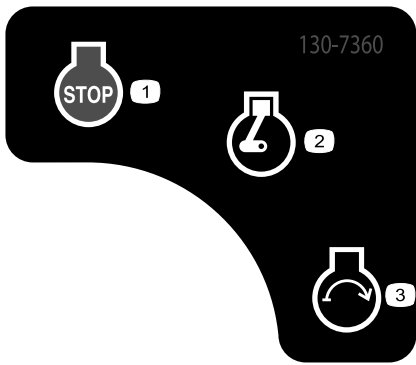

130-7360

1. Engine—off
2. Engine—run/warming
3. Engine—start

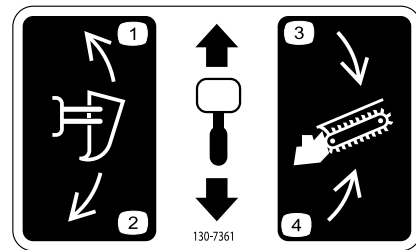

130-7361

1. Raise the plow
2. Lower the plower
3. Lower the trencher
4. Raise the trencher



130-4341

1. Regeneration acknowledge

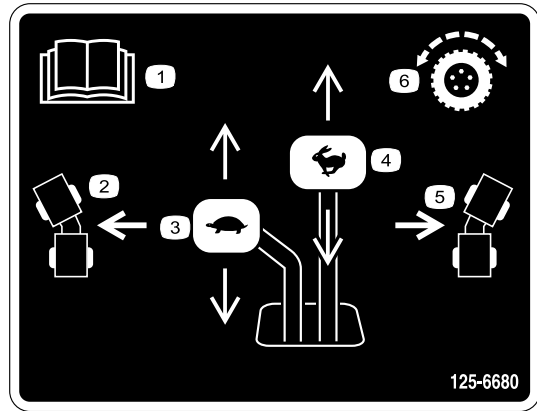

125-6680

1. Read the *Operator's Manual*.
2. Turn left
3. Slow
4. Fast
5. Turn right
6. Traction control

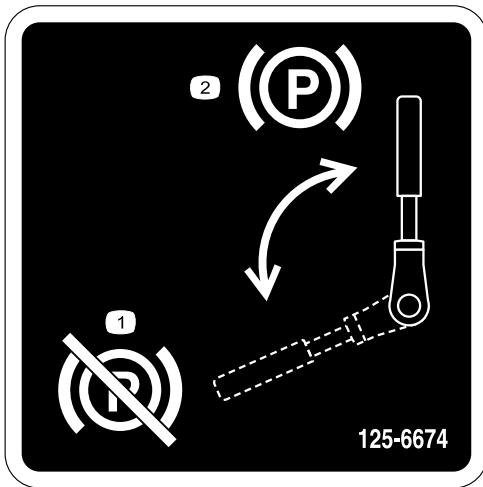

125-6674

1. Disengage the parking brake.
2. Engage the parking brake.

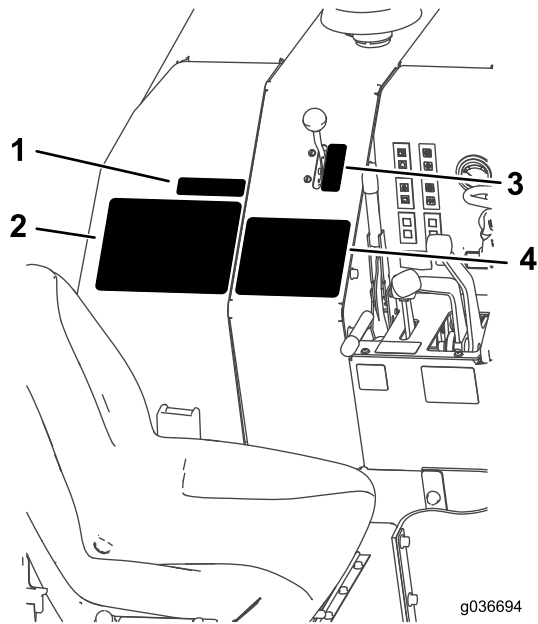

Figure 7

- | | |
|-------------------|-------------------|
| 1. Decal 117-2718 | 3. Decal 130-4340 |
| 2. Decal 130-4343 | 4. Decal 127-1824 |

CALIFORNIA SPARK ARRESTER WARNING

Operation of this equipment may create sparks that can start fires around dry vegetation. A spark arrester may be required. The operator should contact local fire agencies for laws or regulations relating to fire prevention requirements. 117-2718

117-2718

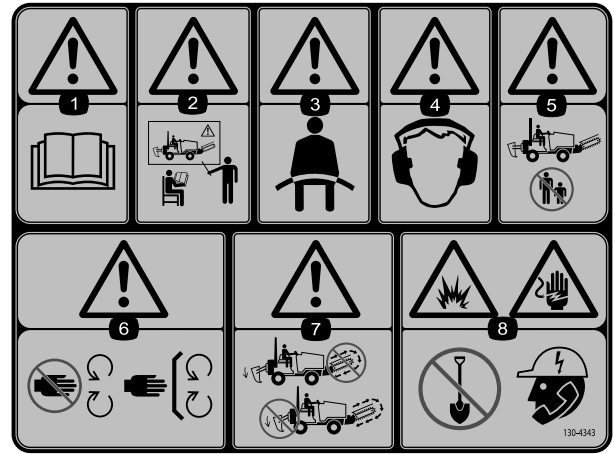

130-4343

- | | |
|---|--|
| 1. Warning—read the <i>Operator's Manual</i> . | 5. Warning—keep bystanders away. |
| 2. Warning—do not operate the machine unless you have received instruction. | 6. Warning—keep away from moving parts; keep all guards and shields in place. |
| 3. Warning—wear a seatbelt. | 7. Warning—do not operate the trencher while using the plow; do not operate the plow while using the trencher. |
| 4. Warning—wear hearing protection. | 8. Explosion hazard; shock hazard—before digging, call the local utilities service. |

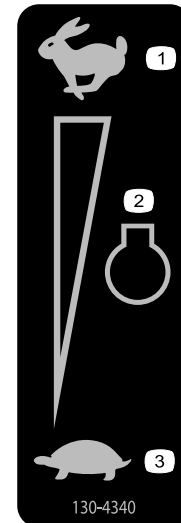

130-4340

- | | |
|-----------------|---------|
| 1. Fast | 3. Slow |
| 2. Engine speed | |

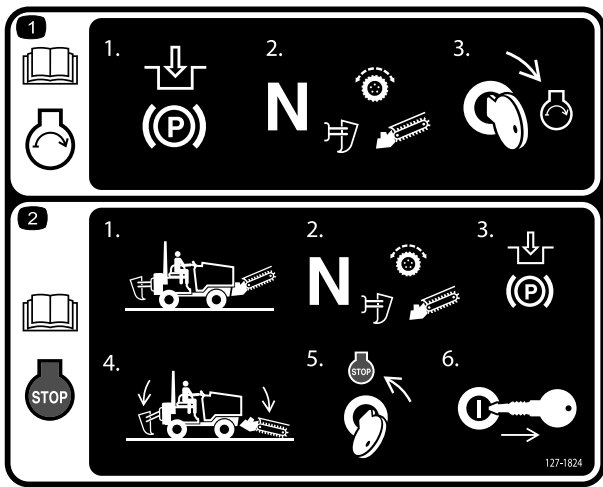

127-1824

1. For more information on starting the engine, read the *Operator's Manual*—1) Engage the parking brake; 2) Set the plow, trencher, and drive to neutral; 3) Turn the key to the engine start position.
2. For more information on shutting off the engine, read the *Operator's Manual*—1) Park the machine on a level surface; 2) Set the plow, trencher, and drive to neutral; 3) Engage the parking brake; 4) Lower all attachments; 5) Turn the key to the engine off position; 6) Remove the key from the ignition.

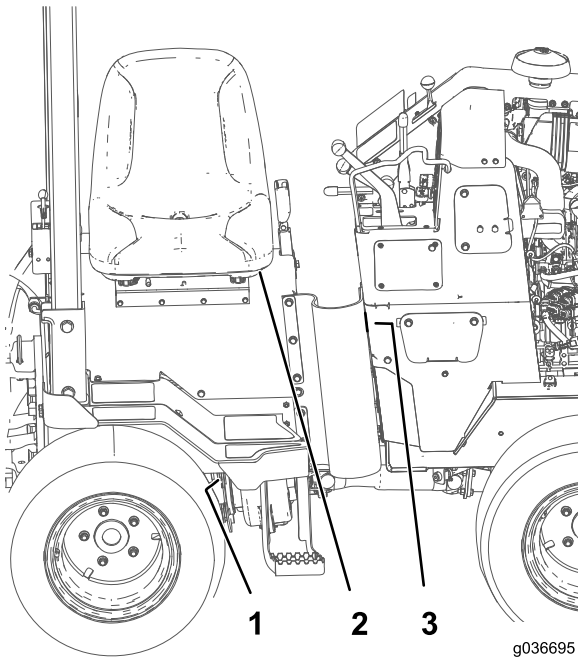
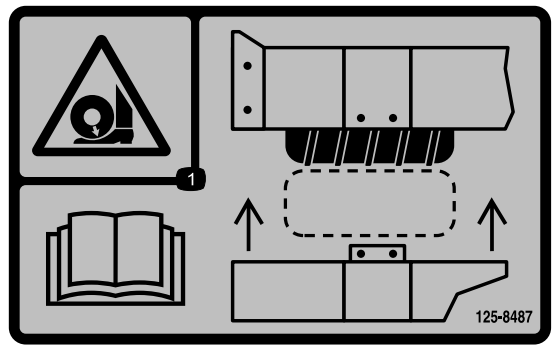

Figure 8

1. Decal 125-8487 (behind the step)
2. Decal 125-6135 (under the seat)
3. Decal 125-8491 (behind the rubber guard)



125-8487

1. Crushing hazard, tire—read the *Operator's Manual*; the extension step must be attached when the tires are in wide or doubled configuration.

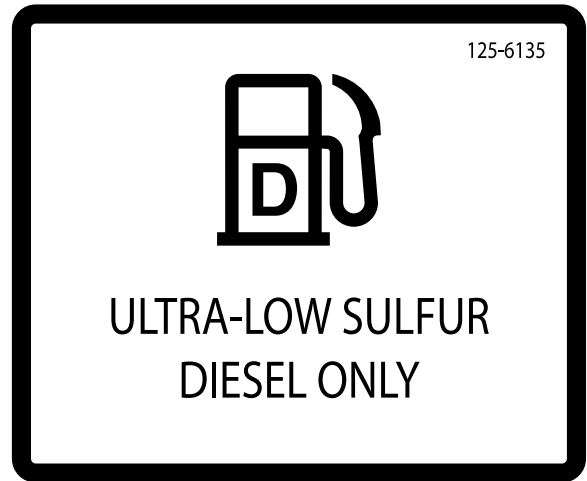

125-6135



125-8491

1. Crushing hazard, warning—keep away from articulated joints; replace missing safety shields.

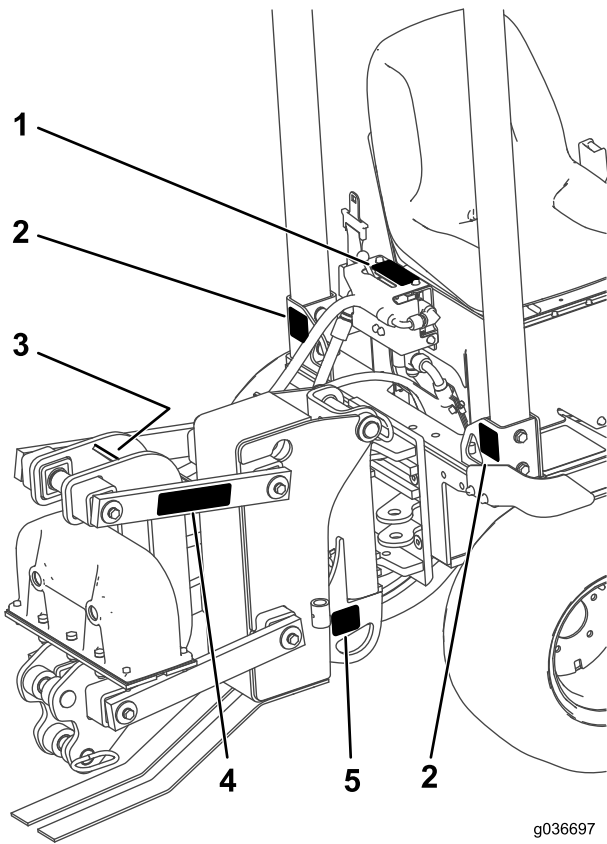

g036697

Figure 9

- | | |
|-------------------|-------------------|
| 1. Decal 127-1822 | 4. Decal 125-6684 |
| 2. Decal 125-4967 | 5. Decal 125-6694 |
| 3. Decal 125-6671 | |

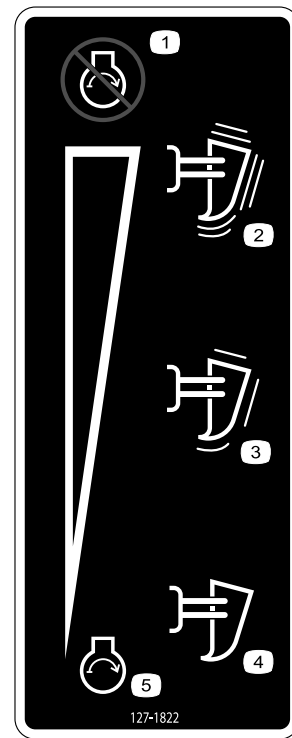

127-1822

- | | |
|--|---|
| 1. The engine cannot start with the plow active. | 4. No vibration |
| 2. High vibration | 5. The engine can start with the plow inactive. |
| 3. Low vibration | |



125-6671

1. Explosion hazard; electric shock hazard—call local utilities before digging.



125-6684

1. Cutting/dismemberment hazard, plow—keep bystanders away from the plow; stay away from moving parts; keep all guards and safeties in place.

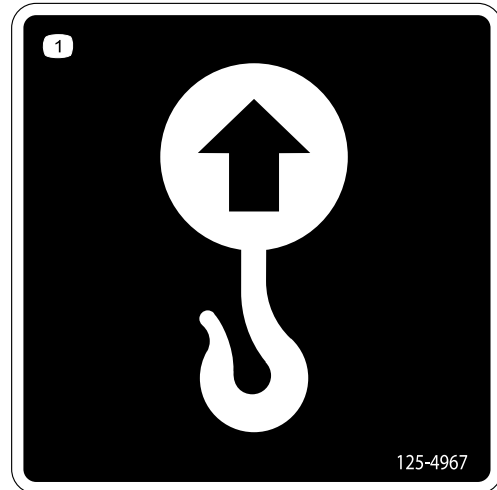

125-4967

1. Lift point

Product Overview

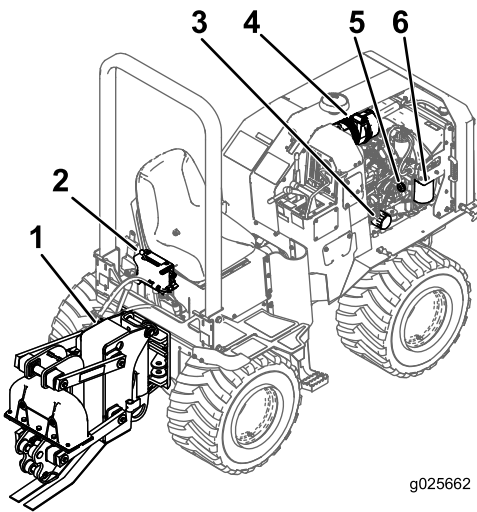

g025662

Figure 10
Right-side view

- | | | |
|---------------------------|----------------------|--------------------------------|
| 1. Vibratory plow control | 3. Engine-oil filter | 5. Engine-oil cap |
| 2. Vibratory-plow control | 4. Air filter | 6. Fuel filter/water separator |

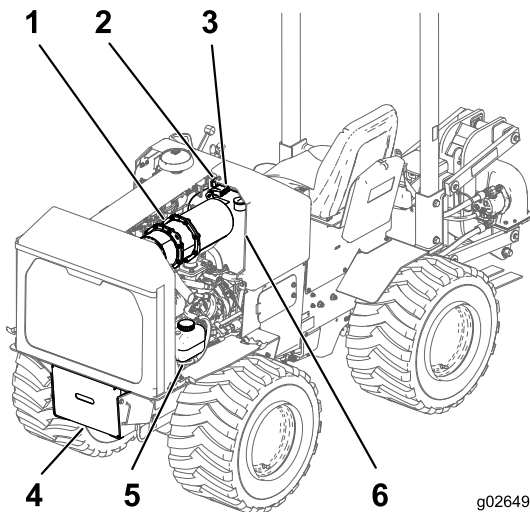

g026498

Figure 11
Left-side view

- | | |
|------------------------------------|---------------------------|
| 1. Diesel-particulate filter (DPF) | 4. Battery |
| 2. Regeneration-inhibit switch | 5. Coolant-expansion tank |
| 3. Fuses | 6. Hydraulic tank |

Controls

Become familiar with all of the controls before you start the engine and operate the machine.

Throttle

The throttle controls the engine speed. Push the knob to increase the engine speed. Pull the knob to decrease the engine speed.

Parking-Brake Lever

To set the parking brake, pull the lever up and push it forward. To release the parking brake, pull the lever back and down.

Attachment Control Lever

The attachment control lever has 2 positions: RAISE and LOWER. The configuration of the machine determines which direction raises or lowers the attachment; refer to the *Operator's Manual* for your attachment to configure your machine.

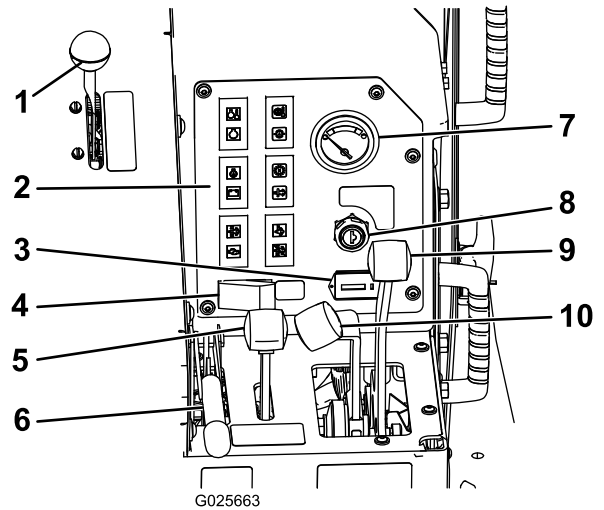

G025663

Figure 12

- | | |
|------------------------------------|----------------------------------|
| 1. Throttle | 6. Parking brake |
| 2. Indicator lights | 7. Fuel gauge |
| 3. Hour meter | 8. Key switch |
| 4. Regeneration-acknowledge switch | 9. Traction-control lever switch |
| 5. Attachment-control lever | 10. Creep-control lever |

Traction-Control Lever

The traction-control lever controls the direction and speed of the machine during transport. To go forward, push the lever forward. To reverse, pull the lever backward. The further you push or pull the lever, the faster the machine travels. To turn, push the lever to the left or right.

Creep-Control Lever

The creep-control lever controls the direction and speed of the machine while the attachments are in use. To go forward, push the lever forward. To reverse, pull the lever backward. The further you push or pull the lever, the faster the machine travels. The creep-control lever will not return to the NEUTRAL position on its own.

Hour Meter

The hour meter displays the number of hours of operation that have been logged on the machine.

Key Switch

The key switch, used to start and shut off the engine, has 3 positions: OFF, ON/PREHEAT, and START. To start the engine, rotate the key to the ON/PREHEAT position. Once the glow plug indicator light is off, rotate the key to the START position. Release the key when engine starts and it will move automatically to the ON position. To shut off the engine, rotate the key to the OFF position.

Fuel Gauge

The fuel gauge measures the amount of fuel in the fuel tank.

Vibratory-Plow Control Lever

This lever controls the vibratory plow. To increase the agitation, push the lever forward. To decrease the agitation, pull the lever back. If the vibratory plow is in use, use the creep-control lever to drive.

Diesel-Particulate Filter (DPF)

⚠ CAUTION

During regeneration, the diesel particulate filter becomes extremely hot and can cause serious burns.

Keep your body and hands away from the engine during regeneration.

The diesel particulate filter (DPF) removes particulate matter from the exhaust and prevents it from being discharged into the air. As the particulates collect in the filter, the engine performs a regeneration to prevent clogging and decreased engine performance. Most regenerations are performed in the background and will not impact operation. These background regenerations happen automatically, unless the regeneration inhibit switch is activated.

Over time, ash accumulates in the DPF and a background regeneration is not sufficient to unclog the filter. When this occurs, the regeneration request and check engine lights illuminate on the control panel. At this time, the filter requires a stationary regeneration or needs to be serviced; contact your Authorized Service Dealer for more information.

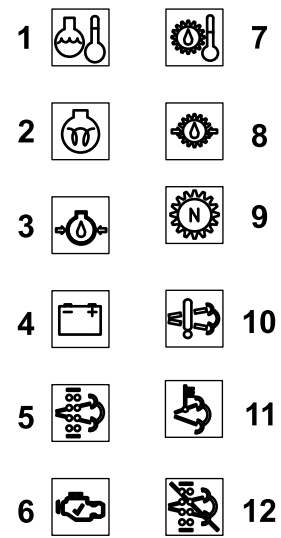

G025668

Figure 13

1. Engine-coolant-temperature light
2. Glow-plug indicator
3. Engine-oil-pressure light
4. Charge indicator
5. Regeneration-request light
6. Check-engine light
7. Hydraulic-oil-temperature light
8. Hydraulic-oil-pressure light
9. Neutral indicator
10. Air-filter light
11. High-temperature-exhaust indicator
12. Regeneration inhibit indicator

Engine-Coolant-Temperature Light

This light illuminates if the engine overheats. If the light illuminates when the engine is running, shut off the engine, remove the key, and check for a possible cause.

Glow-Plug Indicator

This light illuminates while the glow plugs are active. When the light is off, it is safe to start the machine.

Engine-Oil-Pressure Light

This light illuminates if the engine oil pressure drops below a safe level while the engine is running. If the light flickers or remains on, stop the vehicle, turn off the engine, and check the oil level. If the oil level was low, but adding oil does not cause the light to go out when you start the engine, turn the engine off immediately and contact your Authorized Service Dealer for assistance.

Charge Indicator

This light illuminates when the battery is being discharged. If the light illuminates during operation, shut off the machine, turn off the engine, and check for possible causes.

Regeneration-Request Light

This light illuminates along with the high-temperature-exhaust indicator when a regeneration is in process. If this light is illuminated on its own, a stationary regeneration is possible. When a regeneration is requested but the regeneration inhibit switch is active, this light blinks. If this light is illuminated along with the check engine light, the DPF needs servicing; contact your Authorized Service Dealer for more information.

Check-Engine Light

This light illuminates when there is an engine problem. If the light illuminates when the engine is running, shut off the engine, remove the key, and check for a possible cause. If this light is illuminated along with the regeneration request light, your DPF needs servicing; contact your Authorized Service Dealer for more information.

Hydraulic-Fluid-Temperature Light

This light illuminates if the hydraulic system overheats. If the light illuminates when the engine is running, shut off the engine, remove the key, and check for a possible cause.

Hydraulic-Fluid-Filter Light

This light illuminates if the hydraulic fluid filter is in need of service. If this light illuminates when the engine is running, shut off the engine, remove the key, and service the filter.

Neutral Indicator

This light illuminates when all control levers are in the NEUTRAL position.

Air-Filter Light

This light illuminates if the air filter is in need of service. If this light illuminates when the engine is running, shut off the engine, remove the key, and service the air cleaner.

High-Temperature-Exhaust Indicator

This light illuminates when the DPF is undergoing regeneration.

Regeneration-Inhibit Indicator

This light illuminates when automatic background regeneration has been turned off.

Regeneration-Acknowledge Switch

This switch manually activates a stationary regeneration. This light on the switch will illuminate when a stationary regeneration is in progress. If the regeneration request light and the light on the switch are both blinking, the regeneration inhibit switch must be turned off for a background regeneration to occur. If the regeneration request light is illuminated and the light on the switch is blinking, contact your Authorized Service Dealer for more information.

Regeneration-Inhibit Switch

This switch disables the automatic background regeneration.

Specifications

Note: Specifications and design are subject to change without notice.

Width	117 cm (46 inches)
Width (narrow wheels)	91 cm (36 inches)
Length (with vibratory plow)	291 cm (114 inches)
Height	216 cm (85 inches)
Weight	1,329 kg (2,930 lb)
Operating capacity	251 kg (553 lb)
Tipping capacity	717 kg (1,580 lb)
Wheelbase	122 cm (48 inches)

Attachments/Accessories

A selection of Toro approved attachments and accessories is available for use with the machine to enhance and expand its capabilities. Contact your Authorized Service Dealer or Distributor or go to www.Toro.com for a list of all approved attachments and accessories.

Important: Use only Toro approved attachments. Other attachments may create an unsafe operating environment or damage the machine.

Operation

Note: Determine the left and right sides of the machine from the normal operating position.

Important: Before operating, check the fuel and oil level, and remove debris from the machine. Also, ensure that the area is clear of people and debris. You should also know and have marked the locations of all utility lines.

Think Safety First

Carefully read all safety instructions and symbols in the safety section. Knowing this information could help you or bystanders avoid injury.

▲ DANGER

Do not operate on slopes.

Wheels dropping over edges can cause rollovers, which may result in serious injury, death, or drowning.

Read and follow the rollover protection instructions and warnings.

To avoid loss of control and possibility of rollover:

- Do not operate near drop-offs or near water.
- Avoid sudden turns or rapid speed changes.

▲ CAUTION

This machine produces sound levels that can cause hearing loss through extended periods of exposure.

Wear hearing protection when operating this machine.

The use of protective equipment for eyes, ears, hands, feet, and head is recommended.

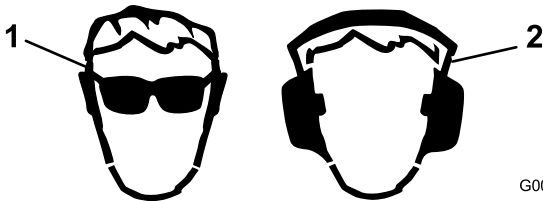

Figure 14

G009027

1. Wear eye protection.
2. Wear hearing protection.

Adding Fuel

Use ultra low sulfur diesel fuel (ULSD) in the engine of this machine. The use of other fuels can cause the loss of engine power and high fuel consumption. The diesel fuel used in this machine must meet the specifications of D975 of ASTM International. See your diesel fuel distributor. The D975 standard defines 2 ULSD standards, Grade No. 2-D S15 (regular ULSD) and Grade No. 1-D S15 (a higher volatility ULSD fuel with a lower gelling temperature than regular ULSD).

Fuel tank capacity: 26.9 L (7.1 US gallons)

Use summer-grade diesel fuel (No. 2-D) at temperatures above 20° F (-7° C) and winter grade (No. 1-D or No. 1-D/2-D blend) below that temperature. Winter-grade fuel at lower temperatures provides lower flash point and cold flow characteristics, which will ease starting and reduce fuel filter plugging.

Summer-grade fuel above 20° F (-7° C) contributes toward longer fuel pump life and increased power compared to winter grade fuel.

Important: Do not use kerosene or gasoline instead of diesel fuel. Failure to observe this caution damages the engine.

This machine can also use a biodiesel blended fuel of up to B20 (20% biodiesel, 80% petrodiesel). The petrodiesel portion should be low or ultra low sulfur. Observe the following precautions:

- The biodiesel portion of the fuel must meet specification ASTM D6751 or EN14214.
- The blended fuel composition should meet ASTM D975 or EN590.
- Painted surfaces may be damaged by biodiesel blends.
- Use B5 (biodiesel content of 5%) or lesser blends in cold weather.
- Monitor seals, hoses, gaskets in contact with fuel as they may be degraded over time.
- Fuel filter plugging may be expected for a time after converting to biodiesel blends.
- Contact your distributor if you wish for more information on biodiesel.

▲ WARNING

Fuel is harmful or fatal if swallowed. Long-term exposure to vapors can cause serious injury and illness.

- Avoid prolonged breathing of vapors.
- Keep face away from nozzle and fuel tank or conditioner opening.
- Keep fuel away from eyes and skin.

Filling the Fuel Tank

▲ DANGER

In certain conditions, fuel is extremely flammable and highly explosive. A fire or explosion from fuel can burn you and others and can damage property.

- Fill the fuel tank outdoors, in an open area, when the engine is cold. Wipe up any fuel that spills.
- Never fill the fuel tank inside an enclosed trailer.
- Never smoke when handling fuel, and stay away from an open flame or where fuel fumes may be ignited by a spark.
- Store fuel in an approved container and keep it out of the reach of children. Never buy more than a 30-day supply of fuel.
- Do not operate without entire exhaust system in place and in proper working condition.

▲ DANGER

In certain conditions during fueling, static electricity can be released causing a spark which can ignite the fuel vapors. A fire or explosion from fuel can burn you and others and can damage property.

- Always place fuel containers on the ground away from your vehicle before filling.
- Do not fill fuel containers inside a vehicle or on a truck or trailer bed because interior carpets or plastic truck bed liners may insulate the container and slow the loss of any static charge.
- When practical, remove equipment from the truck or trailer and refuel the equipment with its wheels on the ground.
- If this is not possible, then refuel such equipment on a truck or trailer from a portable container, rather than from a fuel dispenser nozzle.
- If a fuel dispenser nozzle must be used, keep the nozzle in contact with the rim of the fuel tank or container opening at all times until fueling is complete.

1. Park the machine on a level surface, lower any attachments, shut off the engine, and remove the key.
2. Lift the operator seat to access the fuel tank.
3. Remove the fuel tank cap (Figure 15).

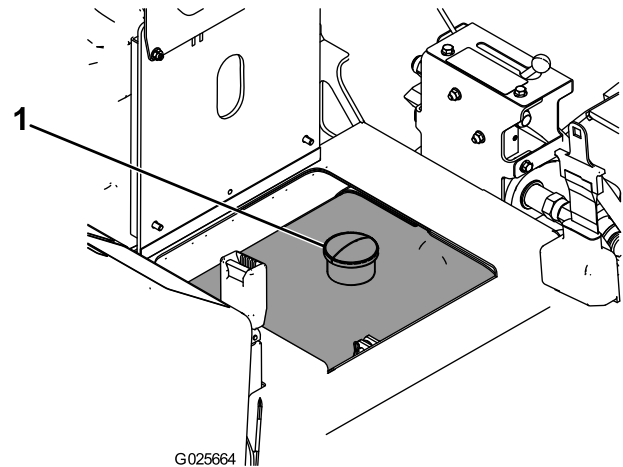

Figure 15

1. Fuel-tank cap

4. Fill the tank to about 2.5 cm (1 inch) below the top of the tank, not the filler neck, with diesel fuel.
5. Install the fuel-tank cap.

Starting and Shutting Off the Engine

Starting the Engine

1. Adjust the seat and fasten the seat belt.
2. Ensure that all of the control levers are in the NEUTRAL position.
3. Move the throttle lever to the SLOW position.
4. Rotate the key to the ON/PREHEAT position.
5. Once the glow plug indicator light is off, rotate the key to the START position. Release the key when engine starts and it will move automatically to the ON position.

Important: Do not engage the starter for more than 10 seconds at a time. If the engine fails to start, allow a 30 second cool-down period between attempts. Failure to follow these instructions can burn out the starter motor.

6. Move the throttle lever to desired setting.

Important: If the engine is run at high speeds when the hydraulic system is cold (i.e., when the ambient air temperature is near freezing or lower), hydraulic system damage could occur. When starting the engine in cold conditions, allow the engine to run in the SLOW position for at least 5 minutes before moving the throttle to Fast (rabbit).

Note: If the outdoor temperature is below freezing, store the machine in a garage to keep it warmer and aid in starting.

Shutting Off the Engine

1. Move the throttle lever to the SLOW position.
2. Lower any attachments to the ground.
3. Set all controls to the NEUTRAL position.
4. Set the parking brake.
5. Turn the ignition key to the OFF position.

Note: If the engine has been working hard or is hot, let it idle for 5 minutes before turning the ignition key off. This helps cool the engine before it is stopped. In an emergency, you can shut off the engine immediately.

Operating the Vibratory Plow

Plowing

1. Remove the rotation pin, place it in the storage location, and start the engine (Figure 16).

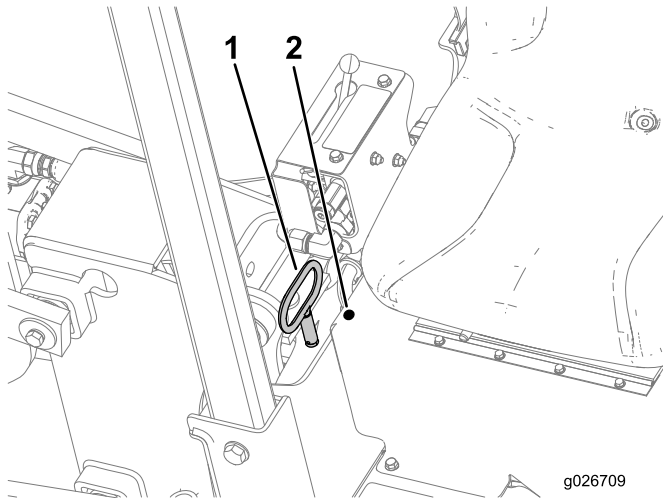

Figure 16

1. Rotation pin
2. Storage location

2. When the engine is warm, push the throttle lever up to full throttle.
3. If the machine is equipped with a trencher, move the attachment selector lever to the cable plow position.
4. Use the attachment control lever to lower the plow to the ground.

Note: The engine turns off in 1 second if the operators seat is empty and the direction control, trencher-digging-control, vibratory-plow lever, or creep-control levers are moved from the NEUTRAL position.

5. Release the parking brake.

Note: Do not start the plow vibration until the blade tip has entered the ground.

6. Move the vibratory-plow lever to start the plow vibration.
7. Slowly lower the plow blade into the ground as the machine moves forward.
8. Use the creep control lever to control the direction and speed of the machine during plowing. The machine will move in the same direction that you move the lever.

Note: The more you push the lever from the Neutral position, the faster the machine travels. The lever will stay in this position when you release the lever. Move the lever to the NEUTRAL position to stop the machine travel.

9. Use the direction or creep control levers to steer the machine to the left or right.

Important: Do not reverse the machine with the plow blade in the ground.

Important: Slowly lift the plow blade out of the ground as the machine moves forward.

Note: Decrease the machine speed if the tires slip or the blade raises out of the ground during plow operation.

10. Reduce the speed of the machine and pull the vibratory-plow lever to stop the plow vibration before raising the blade out of the ground.

Changing the Plow Blade

The plow blades are heavy; use 2 people to complete this procedure.

1. Park the machine on a level surface, lower any attachments, and shut off the engine.

Note: Ensure that the vibratory plow is raised high enough for the blade to be changed.

2. Flip the 2 circular snap rings over and remove the snap-ring pin (Figure 17).

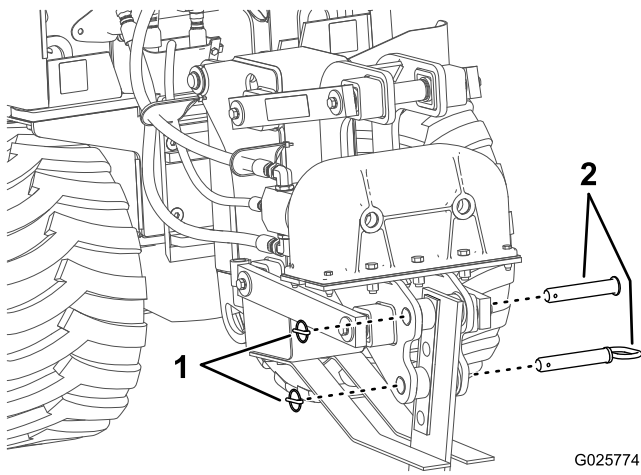

Figure 17

1. Snap-ring pin
2. Pin

3. Pull the 2 pins out of the blade.

Note: The plow blades are heavy. Make sure that 1 person is holding the blade while the other person is removing the pins.

4. Place the new blade into the plow blade assembly and secure it with 2 pins and 2 snap-ring pins.

Removing and Installing the Skid Shoes

1. Raise the plow about 91 cm (36 inches) off the ground.
2. Shut off the engine and remove the key.
3. Remove the 4 bolts, 4 nuts, and 8 washers from the skid shoes (Figure 18).

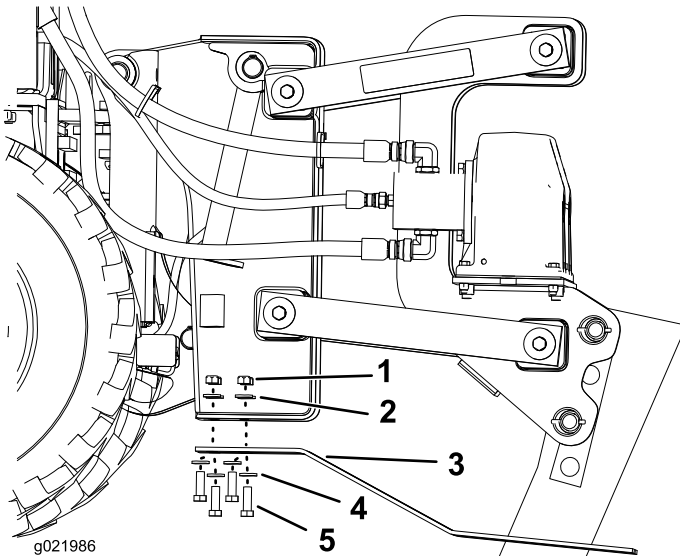

Figure 18

1. Nut
2. Washer
3. Skid shoes
4. Washer
5. Bolt

4. Install the new skid shoes and secure them with the previously removed hardware (Figure 18).

Rotating the Wheels

You can install the wheels to provide a narrow or a wide overall width of machine. Install the wheels with the deep concave toward the machine for operation in tight areas or the shallow concave toward the machine for wider stability.

Important: Only operate on level ground with the narrow wheel configuration.

Tire Size	Ply Rating	Pressure	
		kPa	psi
23 x 10.5 x 12	4	138	20
26 x 12 x 12	8	207	30

1. Park the machine on a level surface, lower any attachments, and shut off the engine.
2. Remove the rear wheels.
3. Remove the step extension from the machine (Figure 19).

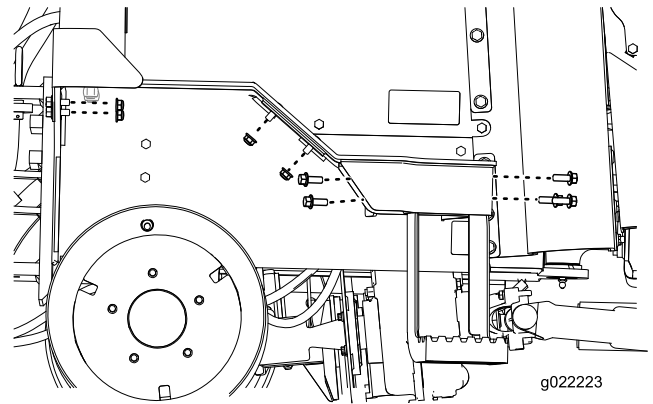

Figure 19

4. Install the wheels on the opposite side of the machine from which each was removed.
5. Remove the front wheels and install them on the opposite side of the machine.

Note: Be sure to keep the tread going in the same direction (Figure 20).

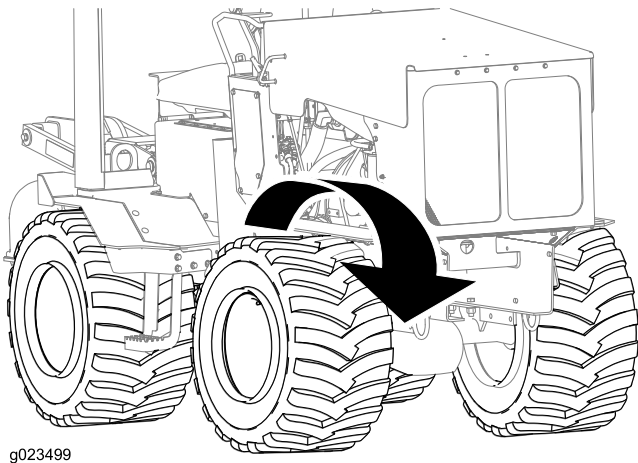

Figure 20

Transporting the Machine

Loading the Machine

Important: Ensure that the trailer and ramp can support both your weight plus the weight of the machine with any attachments.

1. Start the engine.
2. Move the attachments to transport position.
3. Secure the trailer hitch to your vehicle and put a block at the front and rear of the trailer wheels.
4. Move the machine slowly onto the trailer.
5. Lower the attachments onto the trailer and set the parking brake.
6. Shut off the engine and remove the key.
7. Put blocks at the front and rear of each tire of the machine.
8. Fasten the front tie-down loops of the machine to the trailer ([Figure 21](#)).

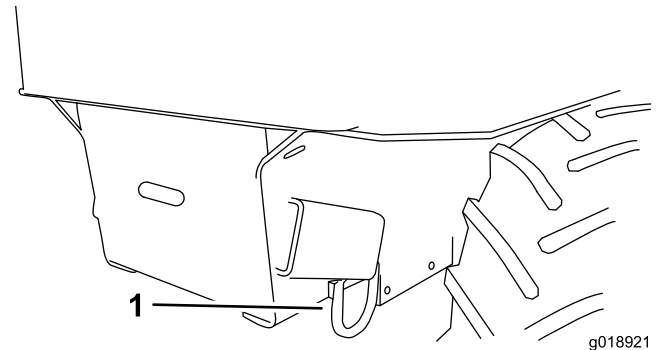

Figure 21

1. Front tie-down loop

Checking the Interlock System

Before using the machine, make the following interlock system checks. If any of these checks fails, contact your Authorized Service Dealer for more information.

- The engine should start with the traction-control lever in the NEUTRAL position and the parking brake engaged.
- The engine should start with the traction-control lever in the NEUTRAL position and the operator in the seat.
- The engine should not crank with the traction-control lever out of the NEUTRAL position and the operator in seat and/or the parking brake engaged.
- The engine should shut off if the traction-control lever is moved out of the NEUTRAL position with the engine running and the parking brake set.
- The engine must shut off if the traction-control lever is moved out of the NEUTRAL position with the engine running and the operator is not in the seat.
- The engine must shut off if the vibratory plow is engaged with the engine running and operator not in the seat.
- The engine must shut off in approximately 1 second if the operator leaves the seated position with the vibratory plow engaged and/or directional control lever out of the Neutral position.
- The engine must shut off if the operator is not on the seat and if the brake is not engaged.

9. Fasten the rear of the machine to the trailer using chains and a binder.

Note: Use the rear tie-down loop ([Figure 22](#)) to secure the machine.

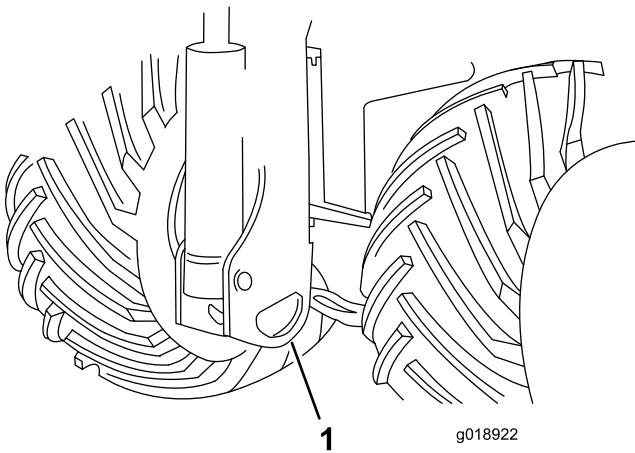

Figure 22

1. Rear tie-down loop
-

10. Measure the distance from the ground to the highest point of the machine to determine the clearance height.
11. Remove the blocks from the front and rear of the trailer wheels.

Important: After transporting the machine a few miles, stop the truck, ensure that the tie-downs are still tight and that the machine has not moved on the trailer.

Unloading the Machine

1. Put a block at the front and rear of the machine and trailer wheels.
2. Remove the ties, then remove the blocks from the machine.
3. Start the engine and release the parking brake. Refer to [Parking-Brake Lever \(page 13\)](#).
4. Ensure that the attachments are in the transport position.
5. Slowly move the machine off of the trailer.

Maintenance

Note: Determine the left and right sides of the machine from the normal operating position.

Important: Refer to your engine *Operator's Manual* for additional maintenance procedures.

Note: Download a free copy of the *Electrical Schematic* or *Hydraulic Schematic* for your machine by visiting www.Toro.com and searching for your machine from the Manuals link on the home page.

⚠ CAUTION

If you leave the key in the ignition switch, someone could accidentally start the engine and seriously injure you or other bystanders.

Remove the key from the ignition before you do any maintenance.

Recommended Maintenance Schedule(s)

Maintenance Service Interval	Maintenance Procedure
After the first 25 hours	<ul style="list-style-type: none"> Replace the hydraulic filter.
After the first 50 hours	<ul style="list-style-type: none"> Change the engine oil and filter.
After the first 250 hours	<ul style="list-style-type: none"> Change the hydraulic fluid.
Before each use or daily	<ul style="list-style-type: none"> Grease the machine (Grease immediately after every washing). Check the air filter service indicator light (more frequently if conditions are dusty or sandy). Check the engine oil Check the fuel filter/water separator. Check the tire pressure. Check the lug nuts. Check and refill the engine coolant. Check the hydraulic-fluid level. Remove debris from the machine and screens. Check for loose fasteners.
Every 50 hours	<ul style="list-style-type: none"> Drain water and other contaminants from the fuel filter/water separator.
Every 100 hours	<ul style="list-style-type: none"> Check the battery electrolyte level (replacement battery only). Check the axle oil levels. Check the cooling system hoses. Check the hydraulic lines for leaks, loose fittings, kinked lines, loose mounting supports, wear, weather, and chemical deterioration. Check for dirt build-up in the chassis.
Every 250 hours	<ul style="list-style-type: none"> Remove the air cleaner cover, clean out any debris, and check the air filter service indicator light (more frequently if conditions are dusty or sandy). Change the engine oil and filter Drain and clean the fuel tank. Check the battery cable connections. Check the transmission oil. Clean the radiator.
Every 400 hours	<ul style="list-style-type: none"> Check the fuel lines and connections for deterioration, damage, or loose connections.
Every 500 hours	<ul style="list-style-type: none"> Replace the air filter (more frequently if conditions are dusty or sandy). Replace the fuel filter/water separator. Check and maintain the ROPS; check it after an accident.

Maintenance Service Interval	Maintenance Procedure
Every 1,000 hours	<ul style="list-style-type: none"> • Change the transmission oil. • Change the engine coolant (See an Authorized Service Dealer). • Check the alternator drive belt tension. • Replace the hydraulic filter. • Change the hydraulic fluid.
Every 1,500 hours	<ul style="list-style-type: none"> • Replace all moving hydraulic hoses.
Every 2,000 hours	<ul style="list-style-type: none"> • Replace the fuel lines and connections.
Every 3,000 hours	<ul style="list-style-type: none"> • Clean or replace the diesel particulate filter.
Every 4,000 hours	<ul style="list-style-type: none"> • Replace the alternator drive belt.
Monthly	<ul style="list-style-type: none"> • Clean the directional controls linkage assembly.
Yearly or before storage	<ul style="list-style-type: none"> • Change the engine oil and filter. • Drain and clean the fuel tank. • Touch up chipped paint.

Premaintenance Procedures

Before opening any of the covers, shut off the engine and remove the key. Allow the engine to cool before opening any covers.

Opening the Hood

Pull the rubber hood latch (on each side of the hood) from the hood bracket (Figure 23) and open the hood.

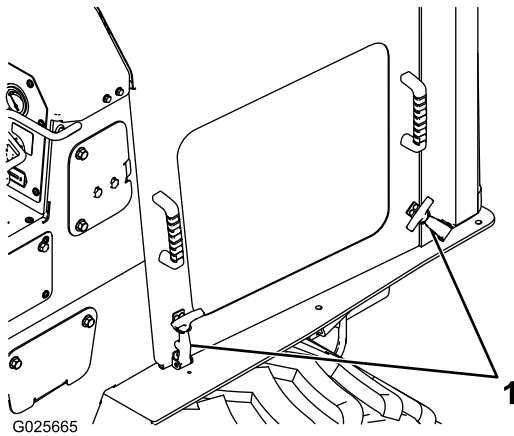

Figure 23

1. Hood latches

Lubrication

Greasing the Machine

Service Interval: Before each use or daily (Grease immediately after every washing).

Grease Type: General-purpose grease.

1. Clean the grease fittings with a rag.
2. Connect a grease gun to each fitting (Figure 24, Figure 25, and Figure 26).

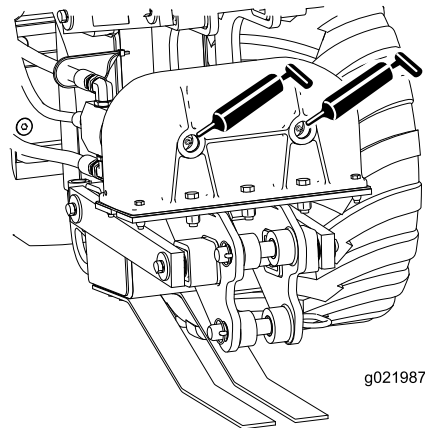

Figure 24

Engine Maintenance

Servicing the Air Cleaner

Service Interval: Before each use or daily—Check the air filter service indicator light (more frequently if conditions are dusty or sandy).

Every 250 hours—Remove the air cleaner cover, clean out any debris, and check the air filter service indicator light (more frequently if conditions are dusty or sandy).

Every 500 hours—Replace the air filter (more frequently if conditions are dusty or sandy).

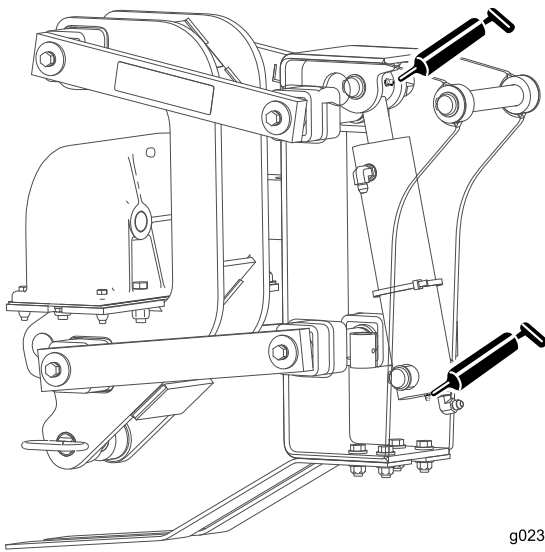

Figure 25

g023247

Servicing the Air-cleaner Cover and Body

Important: Service the air cleaner filter only when the service indicator is illuminated while the engine is running, after 1000 hours of operation or each year, whichever occurs first. Changing the air filter before it is necessary only increases the chance of dirt entering the engine when you remove the filter.

1. Lower the attachment, shut off the engine, and remove the key.
2. Check the air cleaner body for damage which could cause an air leak. Check the whole intake system for leaks, damage, or loose hose clamps. Replace or repair any damaged components.
3. Release the latches on the air cleaner, and pull the air-cleaner housing off the air cleaner body (Figure 27).

Important: Do not remove the air filters.

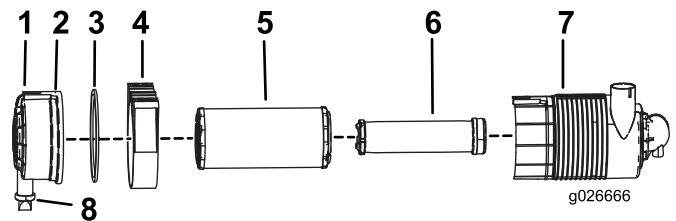

Figure 27

- | | |
|-------------|------------------------|
| 1. Latch | 5. Air filter |
| 2. Dust cap | 6. Safety filter |
| 3. Gasket | 7. Air-cleaner housing |
| 4. Bracket | 8. Dust valve |

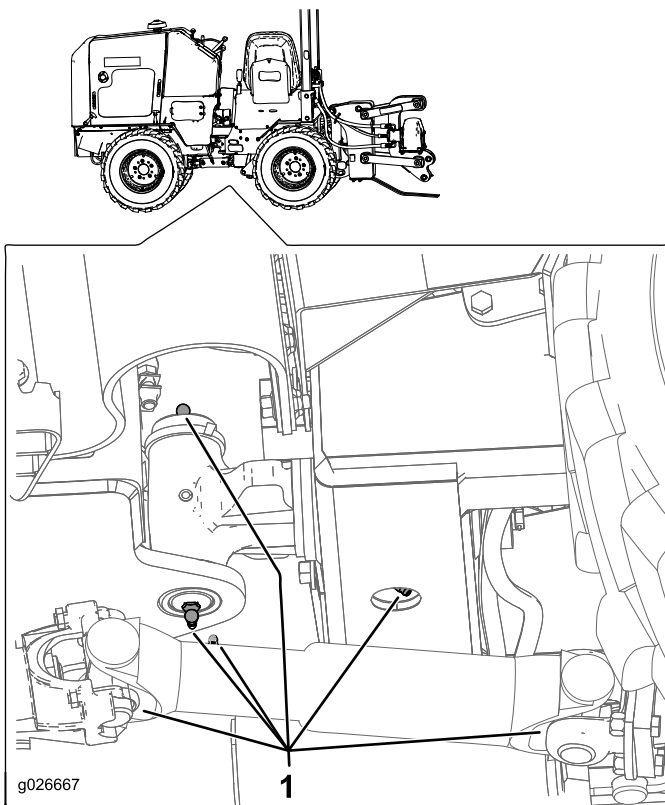

Figure 26
Underside view

1. Grease fittings
3. Pump grease into the fittings (approximately 3 pumps).
4. Wipe up any excess grease.

4. Remove the dust cap and clean the inside with compressed air.
5. Install the dust cap ensuring that the dust valve on the bottom of the dust cap is pointing down.
6. Tighten the latch.

Replacing the Filters

If the air filter light illuminates, perform the following steps.

1. Gently slide the primary filter out of the air cleaner body (Figure 27).

Note: Avoid knocking the filter into the side of the body.

2. Inspect the new filter(s) for damage by looking into the filter while shining a bright light on the outside of the filter.

Note: Holes in the filter will appear as bright spots. Inspect the element for tears, an oily film, or damage to the rubber seal. If the filter is damaged, do not use it.

3. Clean the air filter housing with a moist cloth.
4. Install the new air filter element ensuring that the element is fully seated inside the air filter housing.
5. Install the dust cap ensuring that the dust valve on the bottom of the dust cap is pointing down.
6. Tighten the latch.

Servicing the Safety Filter

Replace the safety filter, never clean it.

Important: Never attempt to clean the safety filter. If the safety filter is dirty, then the primary filter is damaged. Replace both filters.

Servicing the Engine Oil

Service Interval: After the first 50 hours—Change the engine oil and filter.

Before each use or daily—Check the engine oil

Every 250 hours—Change the engine oil and filter

Note: Change oil and oil filter more frequently when operating conditions are extremely dusty or sandy.

The engine is shipped with oil in the crankcase; however, the oil level must be checked before and after the engine is first started.

The crankcase capacity is approximately 5.2 L (5.5 US quarts) with the filter.

Use high-quality engine oil that meets the following specifications:

Oil Type: Detergent diesel engine oil (API service CJ-4 or higher)

Important: Using non CJ-4 or higher oil will cause DPF plugging and damage the engine.

Crankcase Capacity: w/filter, 5.2 L (5.5 US qt)

Viscosity: See Figure 28.

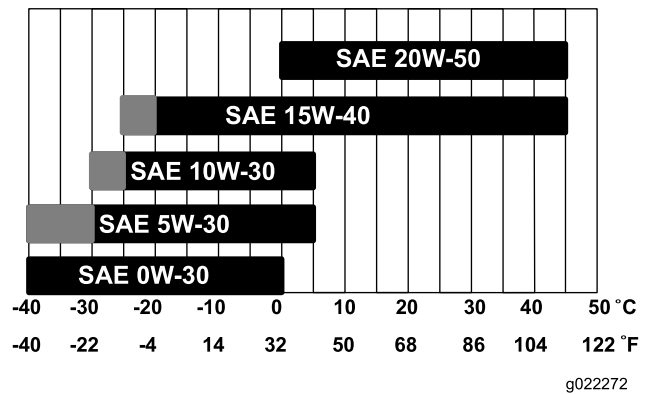

Figure 28

Checking the Engine-Oil Level

The engine is shipped with oil in the crankcase; however, the oil level must be checked before and after the engine is first started.

The best time to check the engine oil is when the engine is cool before it has been started for the day. If it has already been run, allow the oil to drain back down to the sump for at least 10 minutes before checking. If the oil level is at or below the add mark on the dipstick, add oil to bring the oil level to the Full mark. **Do not overfill.** If the oil level is between the Full and Add marks, no oil addition is required.

1. Park the machine on a level surface, lower any attachments, shut off the engine, and remove the key.
2. Unlock the engine cover latches and open the engine cover.
3. Remove the dipstick, wipe it clean, install the dipstick into the tube, and pull it out again.

The oil level should be in the safe range (Figure 29).

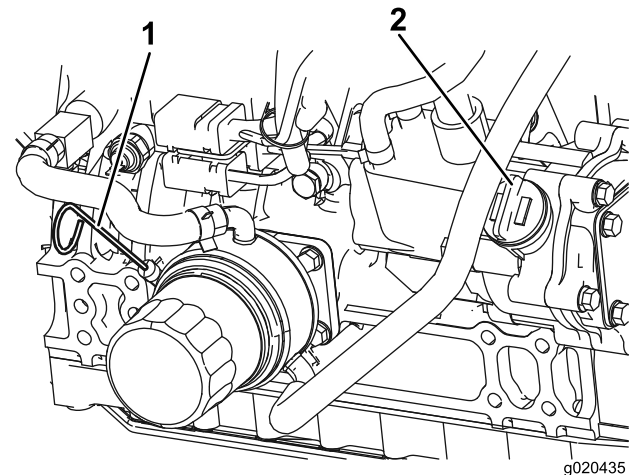

Figure 29

1. Dipstick
2. Oil-fill cap

4. If the oil is below the safe range, remove the fill cap (Figure 29) and add oil until the level reaches the Full mark. **Do not overfill.**

Note: When using different oil, drain all old oil from the crankcase before adding new oil.

5. Install the oil fill cap and dipstick.
6. Close the engine cover and secure it with the latches.

Changing the Engine Oil

1. Start the engine and let it run for 5 minutes. This warms the oil so it drains better.
2. Park the machine on level ground, lower any attachments, set the parking brake, shut off the engine, and remove the key.

⚠ CAUTION

Components will be hot if the machine has been running. If you touch hot components you may be burned.

Allow the machine to cool before performing maintenance or touching components under the hood.

3. Remove the filler cap and the drain plug (Figure 30).

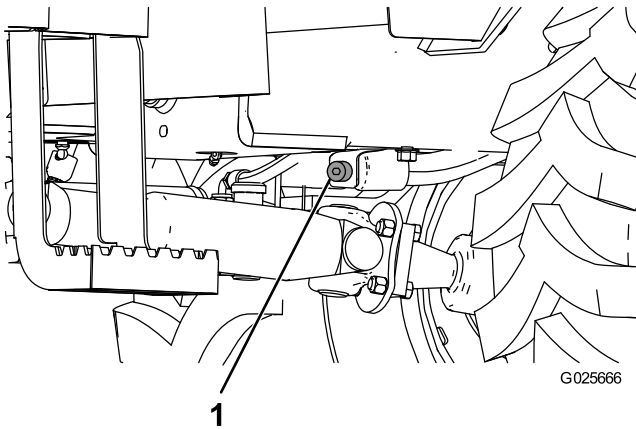

Figure 30

1. Oil-drain plug

4. When the oil has drained completely, install the drain plug.

Note: Dispose of the used oil at a certified recycling center.

5. Slowly pour approximately 80% of the specified amount of oil in through the valve cover.
6. Check the oil level; refer to [Checking the Engine-Oil Level \(page 25\)](#).
7. Slowly add additional oil to bring the level to the upper hole on the dipstick.
8. Replace the fill cap.

Changing the Oil Filter

1. Drain the oil from the engine; refer to [Changing the Engine Oil \(page 26\)](#).
2. Place a shallow pan or rag under the filter to catch the oil.
3. Remove the old filter (Figure 31) and wipe the surface of the gasket seal on the filter head.

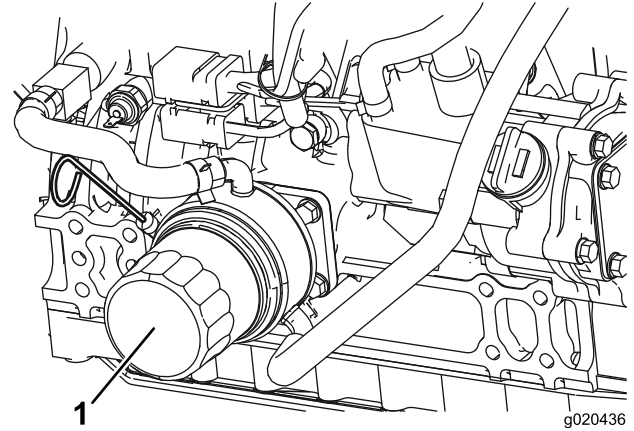

Figure 31

1. Oil filter

4. Apply a thin layer of clean oil to the gasket seal of the new oil filter.
5. Apply a thin coat of the clean oil of the proper type through the center hole of the filter.
6. Allow 2 minutes for the oil to be absorbed by the filter material, then pour off any excess oil.
7. Install the replacement oil filter to the filter adapter by turning the oil filter clockwise until the rubber gasket contacts the filter adapter, then tighten the filter an additional 1/2 turn.
8. Fill the crankcase with the proper type of new oil; refer to [Servicing the Air Cleaner \(page 24\)](#).
9. Start the engine and let it run for 30 seconds. Shut off the engine and let the machine cool.
10. Check the engine oil level; refer to [Checking the Engine-Oil Level \(page 25\)](#).

Servicing the Diesel Particulate Filter (DPF)

Service Interval: Every 3,000 hours

Over time, ash accumulates in the DPF and a background regeneration is not sufficient to unclog the filter. When this occurs, the regeneration request and check engine lights illuminate on the control panel. At this time, the filter requires a stationary regeneration or needs to be replaced; contact your Authorized Service Dealer for more information.

When the ash accumulation reaches 50 g/L, the engine de-rates its power to 85%. At this time, remove the DPF and replace it with a clean DPF. If the DPF is not cleaned at the 50 g/L level, the engine continues to run at the de-rated 85% power level until the ash accumulation reaches 60 g/L. When the ash level reaches 60 g/L, the engine de-rates to 50% power. At this time, the DPF is fully plugged and needs to be removed and replaced with a clean DPF; contact your Authorized Service Dealer for more information.

Fuel System Maintenance

⚠ DANGER

Under certain conditions, diesel fuel and fuel vapors are highly flammable and explosive. A fire or explosion from fuel can burn you and others and can cause property damage.

- **Use a funnel and fill the fuel tank outdoors, in an open area, when the engine is off and is cold. Wipe up any fuel that spills.**
- **Do not fill the fuel tank completely full. Add fuel to the fuel tank until the level is 25 mm (1 inch) below the bottom of the filler neck. This empty space in the tank allows the fuel to expand.**
- **Never smoke when handling fuel, and stay away from an open flame or where fuel fumes may be ignited by a spark.**
- **Store fuel in a clean, safety-approved container and keep the cap in place.**

Checking the Fuel Lines and Connections

Service Interval: Every 400 hours/Yearly (whichever comes first)—Check the fuel lines and connections for deterioration, damage, or loose connections.

Every 2,000 hours/Every 2 years (whichever comes first)—Replace the fuel lines and connections.

Inspect the fuel lines and connections for deterioration, damage, or loose connections. Tighten any loose connections and contact your Authorized Service Dealer for assistance in fixing damaged fuel lines.

Draining the Fuel Filter/Water Separator

Service Interval: Before each use or daily—Check the fuel filter/water separator.

Every 50 hours—Drain water and other contaminants from the fuel filter/water separator.

1. Locate the fuel filter on the right side of the engine and place a clean container under it.
2. Loosen the drain valve on the bottom of the filter canister and allow the water to drain.
3. When finished, tighten the drain valve.

Replacing the Fuel Filter Canister

Service Interval: Every 500 hours—Replace the fuel filter/water separator.

1. Clean the filter head and the outside of the fuel filter.
2. Turn the filter counterclockwise and remove the filter from the filter head.
3. Lubricate the gasket on the new filter canister with clean oil.
4. Install the filter canister by hand until the gasket contacts the filter head, then rotate it an additional 1/2 turn.
5. Start the engine and check for leaks.

Draining the Fuel Tank

Service Interval: Every 250 hours

Have an Authorized Service Dealer drain and clean the fuel tank.

Electrical System Maintenance

Servicing the Battery

Service Interval: Every 100 hours—Check the battery electrolyte level (replacement battery only).

Every 250 hours—Check the battery cable connections.

WARNING

CALIFORNIA Proposition 65 Warning

Battery posts, terminals, and related accessories contain lead and lead compounds, chemicals known to the State of California to cause cancer and reproductive harm.
Wash hands after handling.

Important: The following procedures apply when servicing a (dry) battery that has replaced the original battery. The original (wet) battery does not require service.

Always keep the battery clean and fully charged. Use a paper towel to clean the battery case. If the battery terminals are corroded, clean them with a solution of 4 parts water and 1 part baking soda. Apply a light coating of grease to the battery terminals to reduce corrosion.

Voltage: 12 V, 1,000 cold-cranking A

Charging the Battery

⚠ WARNING

Charging the battery produces gasses that can explode.

Never smoke near the battery and keep sparks and flames away from battery.

Important: Always keep the battery fully charged (1.265 specific gravity). This is especially important to prevent battery damage when the temperature is below 0°C (32°F).

1. Charge the battery for 10 to 15 minutes at 25 to 30 A or 30 minutes at 4 to 6 A (Figure 32).

Note: Do not overcharge the battery.

Drive System Maintenance

Servicing the Tires

Checking the Tires and Lug Nuts

Service Interval: Before each use or daily—Check the tire pressure.

Before each use or daily—Check the lug nuts.

- Do not exceed the rated tire pressure. To ensure long tire life and safe handling, check tire pressure daily, refer to [Checking the Tire Pressure \(page 29\)](#).
- Inspect tires for cuts, slashes, or bulges. Tires with defects need to be replaced or repaired for proper handling and safety.
- Check daily to ensure that all lug nuts are tight. Torque the lug nuts to 81-95 N·m (60-70 ft-lb).

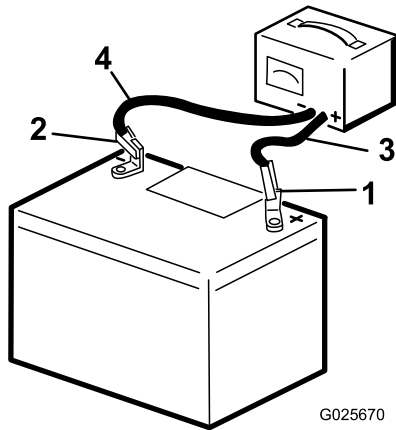

Figure 32

1. Positive battery post
2. Negative battery post
3. Red (+) charger lead
4. Black (-) charger lead

2. When the battery is fully charged, unplug the charger from the electrical outlet, then disconnect the charger leads from the battery posts ([Figure 32](#)).
3. Replace the battery cover.

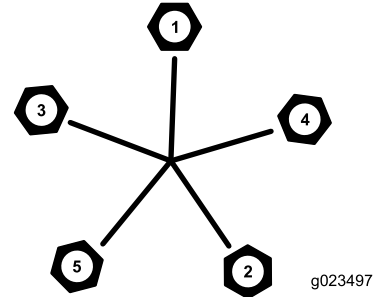

Figure 33

Checking the Tire Pressure

Maintain the air pressure in the tires as specified. Check the tires when they are cold to get the most accurate reading.

Tire Size	Ply Rating	Pressure	
		kPa	psi
23 x 10.5 x 12	4	138	20
26 x 12 x 12	8	207	30

Note: Use a lower tire pressure when operating in sandy soil conditions to provide better traction in the loose soil.

Servicing the Transmission and Axles

Transmission oil specification: SAE 80W140 API classification level GL5

Transmission oil capacity: approximately 0.47 L (0.5 US qt)

Axle oil specification: SAE 80W140 API classification level GL5

Front axle oil capacity: approximately 2.4 L (2.5 US qt)

Rear axle oil capacity: approximately 2.4 L (2.5 US qt)

Toro Premium Gear Oil is available from an Authorized Toro Service Dealer. See the parts catalog for part numbers.

Checking the Transmission Oil

Service Interval: Every 250 hours

1. Park the machine on a level surface, lower any attachments, and shut off the engine.
2. Clean the area around the fill plug with a cleaning solvent (Figure 34).

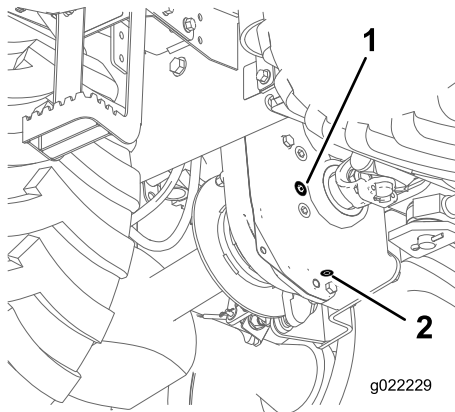

Figure 34

1. Fill plug
2. Drain plug

3. Remove the fill plug.
4. Check the oil level.
Note: The level should be even with the bottom of the fill plug
5. If the oil level is below the bottom of the fill plug hole, add oil to raise the level up to the bottom of the fill plug hole.
6. Install the fill plug.

Changing the Transmission Oil

Service Interval: Every 1,000 hours/Yearly (whichever comes first)

1. Park the machine on a level surface, lower any attachments, and shut off the engine.
2. Clean the area around the fill plug with a cleaning solvent (Figure 35).

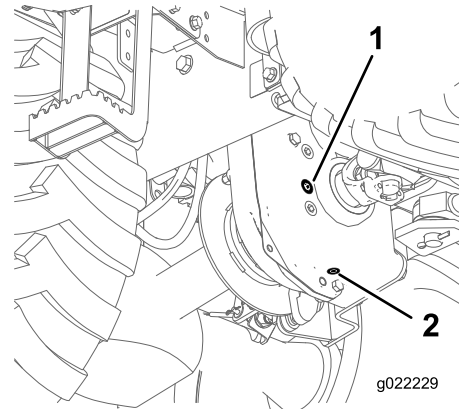

Figure 35

1. Fill plug
2. Drain plug

3. Remove the fill and drain plug.
4. Drain the transmission oil into a container.
5. Insert the drain plug.
6. Fill the transmission until the oil level is even with the bottom of the fill-plug hole.

Checking the Axle Oil Levels

Service Interval: Every 100 hours

1. Park the machine on a level surface, lower any attachments, and shut off the engine.
2. Remove the fill plug from 1 of the axle differentials (Figure 36).

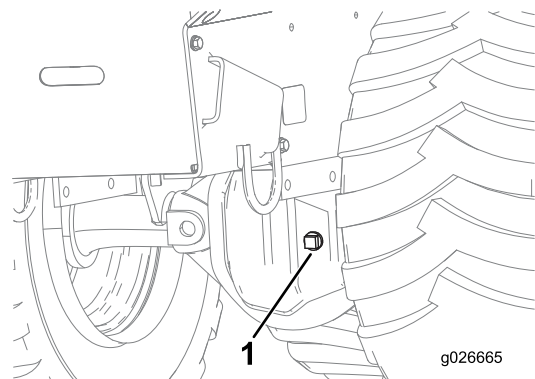

Figure 36

1. Fill plug
3. Check the oil level.

Note: The oil level should be even with the bottom of the fill plug hole.

4. Add oil to raise the oil level up to the bottom of the fill plug hole.
5. Install the fill plug.
6. Repeat for the other differential.

Changing the Axle Oil

1. Place a drain pan under the pinion housing of the axle.
2. Park the machine on a level surface, lower any attachments, and shut off the engine.
3. Remove the bolts securing the cover, and remove the cover and gasket.

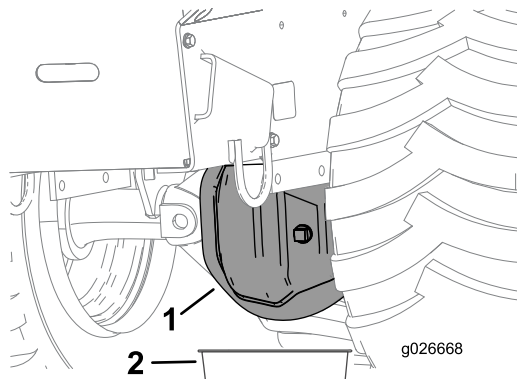

Figure 37

1. Cover
2. Drain pan

4. Clean the surfaces and install a new gasket.
5. Install the cover and drain plug.
6. Remove the fill plug.
7. Fill with differential oil until the oil is level with the bottom of the fill plug hole.
8. Install the fill plug.
9. Repeat the procedure for the other differential.

Cooling System Maintenance

Servicing the Cooling System

Service Interval: Before each use or daily—Check and refill the engine coolant.

Every 100 hours—Check the cooling system hoses.

Every 250 hours—Clean the radiator.

Every 1,000 hours/Yearly (whichever comes first)—Change the engine coolant (See an Authorized Service Dealer).

Coolant specification: a mixture of 50% ethylene glycol and 50% water

Engine and Radiator coolant capacity: 10.2 L (10.8 qt)

⚠ DANGER

If the engine has been running, the pressurized, hot coolant can escape and cause severe burns.

- Do not remove the radiator cap when the engine is hot. Always allow the engine to cool at least 15 minutes or until the radiator cap is cool enough to touch without burning your hand before removing the radiator cap.
- Do not touch radiator and surrounding parts that are hot.
- Use a rag when opening the radiator cap, and open the cap slowly to allow steam to escape.

⚠ DANGER

Rotating shaft and fan can cause personal injury.

- Do not operate the machine without the covers in place.
- Keep fingers, hands and clothing clear of rotating fan and drive shaft.
- Shut off the engine and remove the ignition key before performing maintenance.

⚠ CAUTION

Swallowing engine coolant can cause poisoning.

- Do not swallow engine coolant.
- Keep out of reach from children and pets.

Checking the Engine Coolant Level

Check level of coolant at the beginning of each day. Capacity of the system is 8.5 L (9 qt).

1. Carefully remove the radiator cap.

⚠ CAUTION

If the engine has been running, the pressurized, hot coolant can escape and cause burns.

- Do not open the radiator cap when the engine is running.
- Use a rag when opening the radiator cap, and open the cap slowly to allow steam to escape.

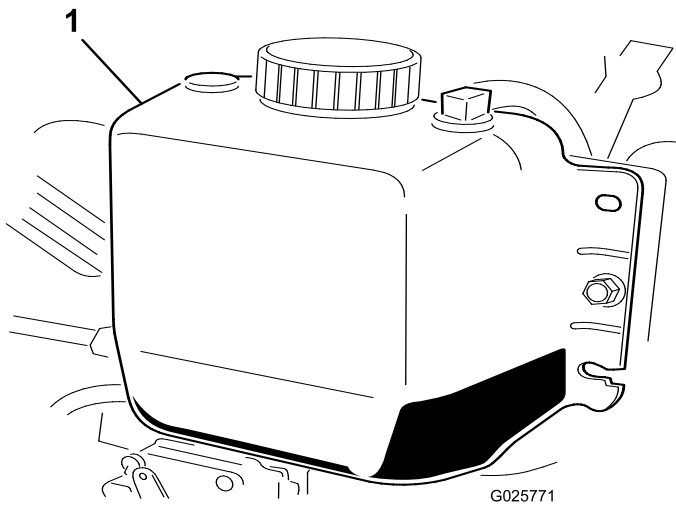

Figure 38

1. Expansion tank

2. Check the coolant level in the radiator.

Note: The radiator should be filled to the top of the filler neck and the expansion tank filled to the Full mark (Figure 38).

3. If the coolant is low, add a 50/50 mixture of water and ethylene glycol anti freeze.

Note: Do not use water only or alcohol/methanol base coolants.

4. Install the radiator cap and expansion tank cap.

Changing the Engine Coolant

Have an Authorized Service Dealer change the engine coolant yearly.

If you need to add engine coolant, refer to [Changing the Engine Coolant](#) (page 32).

Belt Maintenance

Checking the Alternator Drive Belt Tension

Service Interval: Every 1,000 hours

1. Push the drive belt with your thumb in the area shown to check the tension (Figure 39).

Note: The deflection should be between 7 to 10 mm (1/4 to 3/8 inch) under load of 98 N-m (22 ft-lb). If the deflection is less than 7 mm (1/4 inch) or more than 10 mm (3/8 inch), adjust the tension.

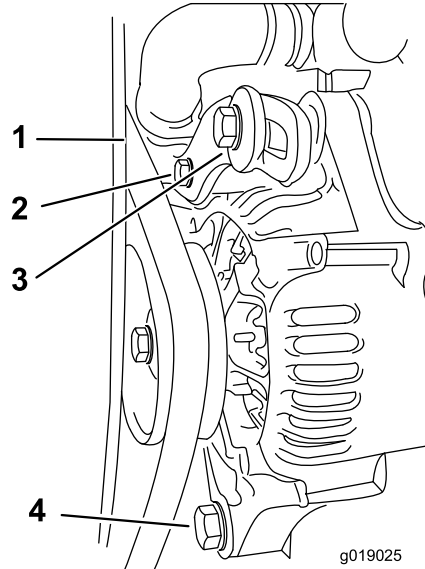

Figure 39

1. Check the tension of the belt here.
2. Pivot bolt
3. Adjusting bolt
4. Pivot bolt

2. Loosen the pivot and adjusting bolts.
3. Pull the alternator away from the engine to increase belt tension or toward the engine to decrease belt tension, then tighten the adjusting bolts.
4. Check the belt tension. If the tension is correct, tighten the pivot bolts.

Replacing the Drive Belt

Service Interval: Every 4,000 hours—Replace the alternator drive belt.

1. Loosen the pivot bolts, the adjusting bolt, and move the alternator toward the engine to loosen the belt tension.
2. Remove the drive belt and install the new drive belt.
3. Adjust the belt tension to between 5 to 8 mm (3/16 to 5/16 inch) under load of 98 N-m (22 ft-lb).
4. Run the engine for 5 minutes and check the tension; the tension should be between 7 to 10 mm (1/4 to 3/8 inch) under load of 98 N-m (22 ft-lb).

Controls System Maintenance

The factory adjusts the controls before shipping the machine. However, after many hours of use, you may need to adjust the controls.

Important: To adjust the controls properly, complete each procedure in the order listed.

Checking the Parking Brake

Move the parking brake lever to the On position. If there is little or no resistance, complete the following procedure:

1. Park the machine on a flat surface, lower any attachments, shut off the engine, and remove the key.
2. Put the parking brake in the Off position.
3. Rotate the handle of the parking brake lever 2 or 3 times clockwise.
4. Apply the parking brake.
 - If there was resistance, the adjustment is correct.
 - If there was little or no resistance, see an Authorized Service Dealer.

Adjusting the Traction Drive for Neutral

When positioned on a level surface, the machine must not creep when the traction lever is released. If it does creep, adjust as follows:

1. Park the machine on a level surface, shut off the engine, and lower the cutting unit to the floor.
2. Block the tires.
3. Loosen the jam nuts on each end of the rod.
4. Adjust the middle nut depending on which way the machine is creeping:
 - If the machine is creeping forward, turn the middle nut counter clockwise.
 - If the machine is creeping backward, turn the middle nut clockwise.

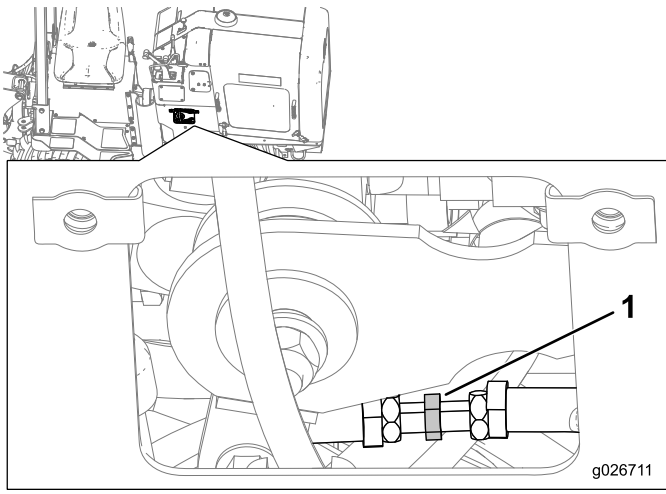

Figure 40

1. Adjustment nut
-
5. Tighten the jam nuts on each end of the rod.
 6. Test the machine to see if further adjustment is needed.

Cleaning the Directional Controls Linkage Assembly

Service Interval: Monthly

Spray the direction controls linkage assembly with compressed air as shown in [Figure 41](#).

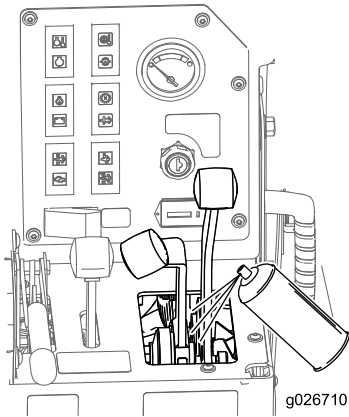

Figure 41

Hydraulic System Maintenance

Servicing the Hydraulic System

Hydraulic fluid reservoir capacity: 25.8 L (6.8 US gallons)

Use only one of the following fluids in the hydraulic system:

Toro Premium All Season Hydraulic Fluid (Available in 5-gallon pails or 55-gallon drums. See *Parts Catalog* or an Authorized Service Dealer for part numbers.)

Alternate fluids: If the Toro fluid is not available, other fluids may be used provided they meet all the following material properties and industry specifications. We do not recommend the use of synthetic fluid. Consult with your lubricant distributor to identify a satisfactory product.

Note: Toro will not assume responsibility for damage caused by improper substitutions, so use only products from reputable manufacturers who will stand behind their recommendation.

High Viscosity Index/Low Pour Point Anti-wear Hydraulic Fluid, ISO VG 46

Material Properties:

Viscosity, ASTM D445	St @ 40° C 44 to 48
	St @ 100° C 7.9 to 8.5
Viscosity Index ASTM D2270	140 to 160
Pour Point, ASTM D97	-34° F to -49° F
FZG, Fail stage	11 or better
Water content (new fluid)	500 ppm (maximum)

Industry Specifications:

Vickers I-286-S (Quality Level),
Vickers M-2950-S (Quality Level),
Denison HF-0

Replacing the Hydraulic Filter

Service Interval: After the first 25 hours

Every 1,000 hours

Important: Do not substitute an automotive oil filter or severe hydraulic system damage may result.

1. Position the machine on a level surface.
2. Lower any attachments, shut off the engine, and remove the key.
3. Place a pan under the hydraulic filter to catch the fluid.
4. Turn the hydraulic-fluid filter counterclockwise, remove and discard the filter (Figure 42).

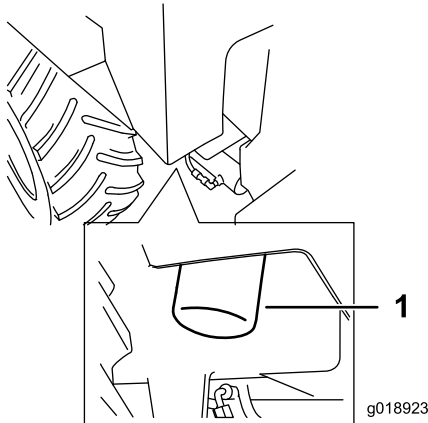

Figure 42

1. Hydraulic-fluid filter

5. Apply a thin coat hydraulic fluid to the rubber gasket on the replacement filter.
6. Fill the hydraulic filter with clean hydraulic fluid.
7. Install the replacement hydraulic filter onto the filter head. Tighten it clockwise until the filter contacts the filter head, then tighten the filter an additional 3/4 turn.
8. Clean up any spilled fluid.
9. Start the engine and let it run for about 2 minutes to purge any air from the system.
10. Shut off the engine and check for leaks.

⚠ WARNING

Hydraulic fluid escaping under pressure can penetrate skin and cause injury. Fluid injected into the skin must be surgically removed within a few hours by a doctor familiar with this form of injury or gangrene may result.

- Keep your body and hands away from pinhole leaks or nozzles that eject high pressure hydraulic fluid.
- Use cardboard or paper to find hydraulic leaks; never use your hands.

Checking the Hydraulic-Fluid Level

Service Interval: Before each use or daily

Important: Always use the correct hydraulic fluid. Unspecified fluids will damage the hydraulic system.

1. Park the machine on a level surface, and lower any attachments.
2. Shut off the engine, remove the key, and allow the engine to cool.
3. Open the hood.
4. Clean the area around the filler neck of the hydraulic tank.

⚠ CAUTION

During regeneration, the diesel particulate filter becomes extremely hot and can cause serious burns.

Keep your body and hands away from the engine during regeneration.

5. Remove the cap from the filler neck and check the fluid level on the dipstick (Figure 43).

The fluid level should be between the marks on the dipstick.

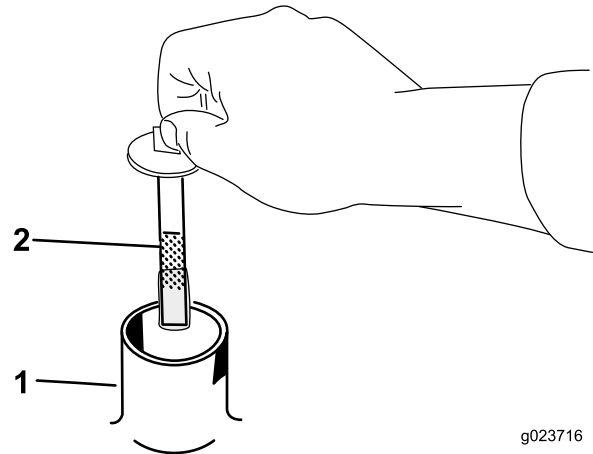

Figure 43

1. Filler neck
2. Dipstick

6. If the level is low, add enough fluid to raise it to the proper level.
7. Install the cap on the filler neck.
8. Close the hood.

Changing the Hydraulic Fluid

Service Interval: After the first 250 hours

Every 1,000 hours/Yearly (whichever comes first)

1. Position the machine on a level surface.
2. Remove the upper left panel of the console (Figure 44).

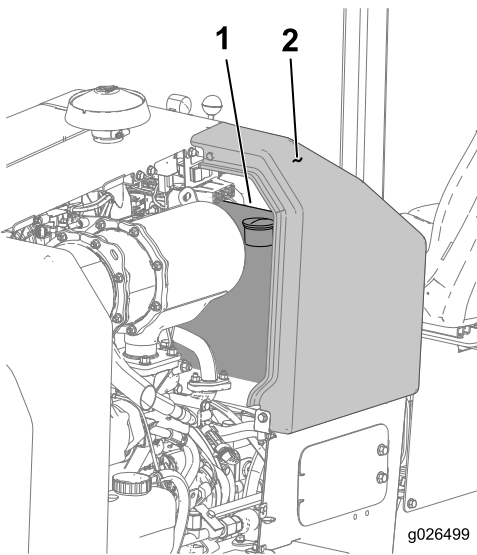

Figure 44

1. Hydraulic tank
2. Upper left panel

3. Place a large drain pan (capable of holding 57 liters (15 US gallons)) on the ground under the hydraulic tank.
4. Remove the hydraulic tank cap and use a pump to empty the hydraulic tank.
5. Remove the lower right side cover plate and loosen the hose clamp holding the suction hose to the hydraulic tank (Figure 45).

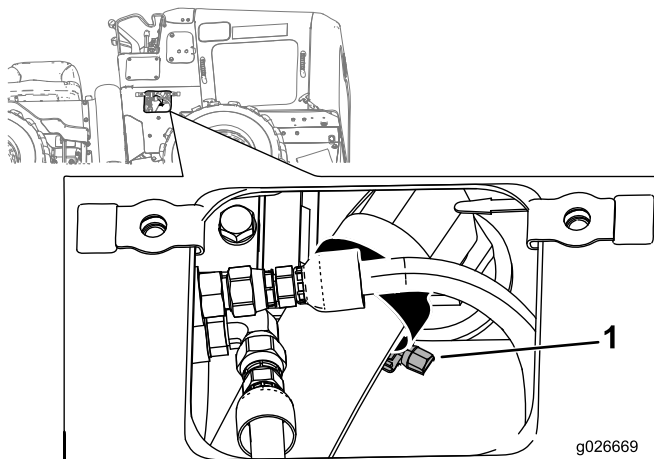

Figure 45

1. Hose clamp

6. Remove the left side cover plate and loosen the 3 hose clamps under the hydraulic tank (Figure 46).

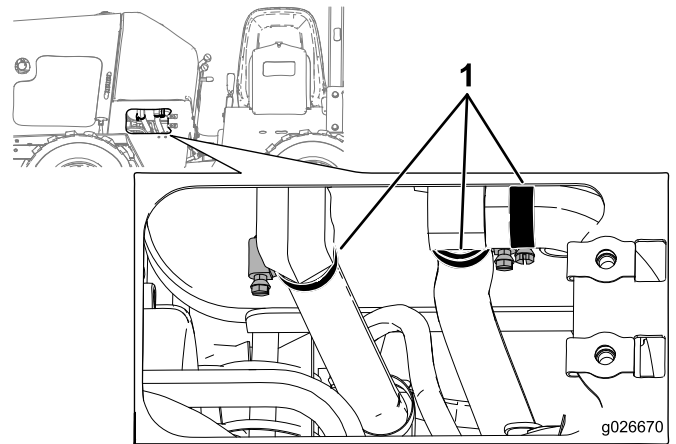

Figure 46

1. Hose clamp

7. Disconnect the electrical lead to the oil temperature sending unit at the bottom of the reservoir.
8. Loosen the hydraulic tank straps and remove the hydraulic tank from the machine (Figure 47).

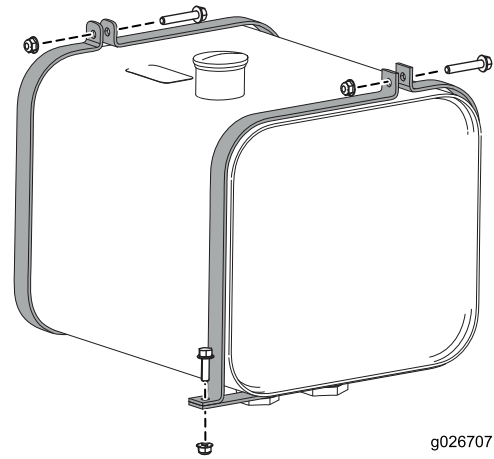

Figure 47

9. Flush the reservoir with cleaning solvent.
10. Remove the elbow adapters and remove and clean the filter screens with compressed air (Figure 48).

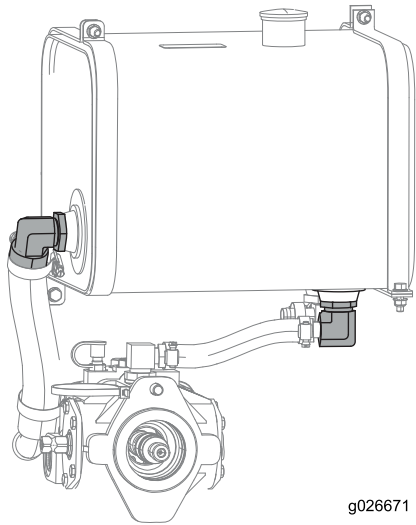

Figure 48

11. Put thread sealant on the threads of the suction screen and install the screen, elbow, hose, and clamp.
12. Connect the electrical lead to the oil temperature sending unit at the bottom of the reservoir.
13. Install the hose to the tank and secure the clamps.
14. Install the hydraulic tank assembly.
15. Fill the hydraulic tank with approximately 25.8 L (6.8 US gallons) of Toro premium all season hydraulic fluid ISO VG 46.

Dispose of the used oil at a certified recycling center.

16. Install the dipstick cap.
17. Start the engine and let it run for a few minutes.
18. Shut off the engine.
19. Check the hydraulic fluid level and top it off if necessary; refer to [Checking the Hydraulic-Fluid Level \(page 35\)](#).

Checking the Hydraulic Lines

Service Interval: Every 100 hours—Check the hydraulic lines for leaks, loose fittings, kinked lines, loose mounting supports, wear, weather, and chemical deterioration. (Make necessary repairs before operating.)

Every 1,500 hours/Every 2 years (whichever comes first)—Replace all moving hydraulic hoses.

⚠ WARNING

Hydraulic fluid escaping under pressure can penetrate skin and cause injury. Fluid injected into the skin must be surgically removed within a few hours by a doctor familiar with this form of injury or gangrene may result.

- **Keep your body and hands away from pinhole leaks or nozzles that eject high pressure hydraulic fluid.**
- **Use cardboard or paper to find hydraulic leaks; never use your hands.**

ROPS Maintenance

Checking and Servicing the ROPS

Checking and Caring for the Seat Belt

Before you operate the machine, always ensure that the ROPS and the seat belt are properly installed and in good working order.

1. Check the seat belt for damage, and replace all parts that are damaged.
2. Ensure that the mounting bolts for the seat belts are tight.
3. Keep the seat belts clean using only soap and water.

Note: Do not immerse the seat belts in bleach or dye, because this weakens the belt material.

Checking and Maintaining the ROPS

Service Interval: Every 500 hours

Important: If any part of the ROPS system is damaged, replace it before you operate the machine.

1. Check that the 4 bolts that secure the ROPS bar to the chassis of the machine are torqued to 203 to 223 N·m (150 to 165 ft-lb); refer to [Figure 49](#).

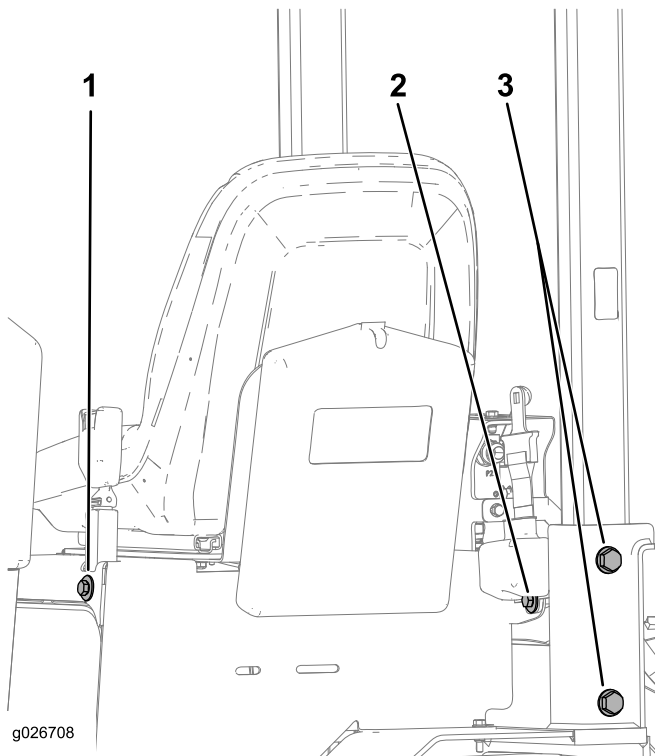

Figure 49

1. Seat belt bolt
2. Seat belt retractor end bolt
3. ROPS bolts

2. Check that the bolts and nuts that attach the seat-belt retractor and buckle to the seat are torqued to 104 to 115 N·m (77 to 85 ft-lb); refer to [Figure 49](#).

Note: Replace any parts that are worn or damaged.

3. Inspect the ROPS for cracks, rust, or holes in the ROPS and component parts.

Note: Age, weather, and accidents cause damage to the ROPS and ROPS parts. If you have any doubts about the ROPS system, contact an Authorized Toro Service Dealer.

Replacing a Damaged ROPS System

If the ROPS system has been damaged in an accident, such as a rollover or hitting an overhead object during transport, replace any damaged ROPS components to restore the ROPS system to its original level of protection.

After an accident, check the following items for damage:

- The ROPS bar
- Operator seat
- Seat belt mounting
- Seat belt

Before you operate the machine, replace all damaged ROPS components; contact an Authorized Toro Service Dealer.

Important: Do not try to weld or straighten a damaged ROPS bar.

Cleaning

Removing Debris from the Machine

Service Interval: Before each use or daily

Important: Operating the engine with blocked screens and/or cooling shrouds removed, will result in engine damage from overheating.

1. Park the machine on a level surface, lower any attachments, and shut off the engine.
2. Remove the key and allow the engine to cool.
3. Open the hood.
4. Clean any debris from the front and side screens.
5. Wipe away any debris from the air cleaner.
6. Clean any debris build-up on the engine and in the oil cooler fins with compressed air.

Important: It is preferable to blow dirt out, rather than washing it out. If water is used, keep it away from electrical items and hydraulic valves. Do not use a high-pressure washer. High-pressure washing can damage the electrical system and hydraulic valves or deplete grease.

7. Clean debris from the hood opening, muffler, and heat shields.
8. Close the hood.

Cleaning the Chassis

Service Interval: Every 100 hours—Check for dirt build-up in the chassis.

Over time, the chassis under the engine collects dirt and debris that must be removed. Using a flashlight, open the hood and inspect the area under the engine on a regular basis. When the debris is 2 to 5 cm (1 to 2 inches) deep, have an Authorized Service Dealer remove the rear of the machine, fuel tank, and battery and flush the chassis clean.

Storage

1. Lower any attachments, shut off the engine, and remove the key.
2. Remove dirt and grime from the entire machine.

Important: You can wash the machine with mild detergent and water. Do not pressure wash the machine. Avoid excessive use of water, especially near the control panel, engine, hydraulic pumps, and motors.

3. Service the air cleaner; refer to [Servicing the Air Cleaner \(page 24\)](#).
4. Grease the machine; refer to [Greasing the Machine \(page 23\)](#).
5. Change the engine oil; refer to [Changing the Engine Oil \(page 26\)](#).
6. Charge the battery; refer to [Charging the Battery \(page 28\)](#).
7. Check and tighten all bolts, nuts, and screws. Repair or replace any part that is damaged.
8. Paint all scratched or bare metal surfaces and replace any missing or damaged decals. Paint and decals are available from your Authorized Service Dealer.
9. Drain the fuel from the fuel tank; refer to [Fuel System Maintenance \(page 27\)](#).
10. Store the machine in a clean, dry garage or storage area. Remove the key from the ignition switch and keep it in a memorable place.
11. Cover the machine to protect it and keep it clean.

Troubleshooting

Problem	Possible Cause	Corrective Action
The starter does not crank.	<ol style="list-style-type: none"> 1. The controls are not in the neutral position. 2. The electrical connections are corroded or loose. 3. A fuse is blown or loose. 4. The battery is discharged. 5. The relay or switch is damaged. 6. A damaged starter or starter solenoid. 7. Seized internal engine components. 	<ol style="list-style-type: none"> 1. Move all of the controls to the Neutral position. 2. Check the electrical connections for good contact. 3. Correct or replace the fuse. 4. Charge the battery or replace it. 5. Contact your Authorized Service Dealer. 6. Contact your Authorized Service Dealer. 7. Contact your Authorized Service Dealer.
The engine cranks, but does not start.	<ol style="list-style-type: none"> 1. The starting procedure was performed incorrectly. 2. The fuel tank is empty. 3. The fuel shut-off valve is closed. 4. Dirt, water, stale fuel, or incorrect fuel is in the fuel system. 5. The fuel line is clogged. 6. There is air in the fuel. 7. The glow plus are inoperative. 8. The cranking speed is too slow. 9. The air cleaner filters are dirty. 10. The fuel filter is clogged. 11. The diesel particular filter is clogged. 12. Improper fuel grade is being used for cold weather use. 13. The compression is low. 14. The injection nozzles or pumps are malfunctioning. 15. The ETR solenoid is broken. 	<ol style="list-style-type: none"> 1. Refer to Starting and Stopping the Engine. 2. Fill the fuel tank with fresh fuel. 3. Open the fuel shut off valve. 4. Drain and flush the fuel system; add fresh fuel. 5. Clean or replace the fuel line. 6. Bleed the nozzles and check for air leaks at the fuel hose connections and fittings between the fuel tank and engine. 7. Check the fuse, glow plugs, and wiring. 8. Check the battery, oil viscosity, and starting motor (contact your Authorized Service Dealer). 9. Service the air filters. 10. Replace the fuel filter. 11. Contact your Authorized Service Dealer. 12. Drain the fuel system and replace the fuel filter. Add fresh fuel of proper grade for ambient temperature conditions. You may need to warm the entire machine. 13. Contact your Authorized Service Dealer. 14. Contact your Authorized Service Dealer. 15. Contact your Authorized Service Dealer.

Problem	Possible Cause	Corrective Action
The engine starts, but does not keep running.	<ol style="list-style-type: none"> 1. The fuel tank vent is restricted. 2. There is dirt or water in the fuel system. 3. The fuel filter is clogged. 4. There is air in the fuel system. 5. Improper fuel grade is being used for cold weather use. 6. The spark arrestor screen is clogged. 7. The fuel pump is damaged. 	<ol style="list-style-type: none"> 1. Loosen the cap. If the engine runs with the cap loosened, replace the cap. 2. Drain and flush the fuel system; add fresh fuel. 3. Replace the fuel filter. 4. Bleed the nozzles and check for air leaks at fuel hose connections and fittings between the fuel tank and engine. 5. Drain the fuel system and replace the fuel filter. Add fresh fuel of proper grade for ambient temperature conditions. 6. Clean or replace the spark arrestor screen. 7. Contact your Authorized Service Dealer.
The engine runs, but knocks or misses.	<ol style="list-style-type: none"> 1. There is dirt, water, stale fuel, or incorrect fuel in the fuel system. 2. The engine is overheating. 3. There is air in the fuel system. 4. The injection nozzles are damaged. 5. The compression is low. 6. The injection pump timing is incorrect. 7. There is excessive carbon build-up. 8. There is internal wear or damage. 	<ol style="list-style-type: none"> 1. Drain and flush the fuel system; add fresh fuel. 2. Refer to troubleshooting item The engine overheats. 3. Bleed nozzles and check for air leaks at the fuel hose connections and fittings between the fuel tank and engine. 4. Contact your Authorized Service Dealer. 5. Contact your Authorized Service Dealer. 6. Contact your Authorized Service Dealer. 7. Contact your Authorized Service Dealer. 8. Contact your Authorized Service Dealer.
The engine does not idle.	<ol style="list-style-type: none"> 1. The fuel tank vent is restricted. 2. There is dirt, water, stale fuel, or incorrect fuel in the fuel system. 3. The air cleaner filters are dirty. 4. The fuel filter is clogged. 5. There is air in the fuel. 6. The fuel pump is damaged. 7. The compression is low. 	<ol style="list-style-type: none"> 1. Loosen the cap. If the engine runs with the cap loosened, replace the cap. 2. Drain and flush the fuel system; add fresh fuel. 3. Service the air filters. 4. Replace the fuel filter. 5. Bleed the nozzles and check for air leaks at fuel hose connections and fittings between the fuel tank and engine. 6. Contact your Authorized Service Dealer. 7. Contact your Authorized Service Dealer.

Problem	Possible Cause	Corrective Action
The engine overheats.	<ol style="list-style-type: none"> 1. More coolant is needed. 2. There is restricted air flow to the radiator. 3. The crankcase oil level is incorrect. 4. The engine load is too excessive. 5. There is incorrect fuel is in the fuel system. 6. The thermostat is damaged. 7. The fan belt is loose or broken. 8. The injection timing is incorrect. 9. the coolant pump is damaged. 	<ol style="list-style-type: none"> 1. Check and add coolant. 2. Inspect and clean the side panel screens with every use. 3. Fill or drain the oil to the full mark. 4. Reduce the load; use lower ground speed. 5. Drain and flush the fuel system; add fresh fuel. 6. Contact your Authorized Service Dealer. 7. Contact your Authorized Service Dealer. 8. Contact your Authorized Service Dealer. 9. Contact your Authorized Service Dealer.
Excessive black smoke from exhaust.	<ol style="list-style-type: none"> 1. The engine load is too excessive. 2. The air cleaner filters are dirty. 3. There is incorrect fuel is in the fuel system. 4. The injection pump timing is incorrect. 5. The injection pump is damaged. 6. The injection nozzles are damaged. 	<ol style="list-style-type: none"> 1. Reduce the load; use lower ground speed. 2. Service the air filters. 3. Drain the fuel system and refill with specified fuel. 4. Contact your Authorized Service Dealer. 5. Contact your Authorized Service Dealer. 6. Contact your Authorized Service Dealer.
Excessive white smoke from exhaust.	<ol style="list-style-type: none"> 1. The key was turned to the start position before the glow plug light turned off. 2. The engine temperature is low. 3. The glow plugs are inoperative. 4. The injection pump timing is incorrect. 5. The injection nozzles are damaged. 6. The compression is low. 	<ol style="list-style-type: none"> 1. Turn the key to the run position and allow the glow plug light to turn off before starting the engine. 2. Check the thermostat. 3. Check the fuse, glow plugs and wiring. 4. Contact your Authorized Service Dealer. 5. Contact your Authorized Service Dealer. 6. Contact your Authorized Service Dealer.

Problem	Possible Cause	Corrective Action
The engine loses power.	<ol style="list-style-type: none"> 1. The engine load is excessive. 2. The crankcase oil level is incorrect. 3. The air cleaner filters are dirty. 4. There is dirt, water, stale fuel, or incorrect fuel is in the fuel system. 5. The engine is overheating. 6. The diesel particulate filter needs servicing. 7. The spark arrestor screen is clogged. 8. There is air in the fuel. 9. The compression is low. 10. The fuel tank vent is restricted. 11. The injection pump timing is incorrect. 12. The injection pump is damaged. 	<ol style="list-style-type: none"> 1. Reduce the load; use lower ground speed. 2. Fill or drain to the full mark. 3. Service the air filters. 4. Drain and flush the fuel system; add fresh fuel. 5. Refer to troubleshooting item The engine is overheating. 6. Contact your Authorized Service Dealer. 7. Clean or replace the spark arrestor screen. 8. Bleed the nozzles and check for air leaks at fuel hose connections and fittings between the fuel tank and engine. 9. Contact your Authorized Service Dealer. 10. Contact your Authorized Service Dealer. 11. Contact your Authorized Service Dealer. 12. Contact your Authorized Service Dealer.
The machine does not drive.	<ol style="list-style-type: none"> 1. The parking brake is on. 2. The hydraulic fluid level is low. 3. The pump and/or wheel motor is damaged. 4. The relief valve is damaged. 	<ol style="list-style-type: none"> 1. Release the parking brake. 2. Add hydraulic fluid to the reservoir. 3. Contact your Authorized Service Dealer. 4. Contact your Authorized Service Dealer.



The Toro Warranty

A One-Year Limited Warranty

Compact Utility Equipment
(CUE) Products

Conditions and Products Covered

The Toro Company and its affiliate, Toro Warranty Company, pursuant to an agreement between them, jointly warrant your Toro Compact Utility Equipment ("Product") to be free from defects in materials or workmanship. The following time periods apply from the date of purchase:

Products	Warranty Period
Pro Sneak Compact Tool Carriers, Trenchers, Stump Grinders, and Attachments	1 year or 1000 operating hours, whichever occurs first
Kohler Engines	3 years*
All other Engines	2 years*

Where a warrantable condition exists, we will repair the Product at no cost to you including diagnosis, labor, and parts.

*Some engines used on Toro Products are warranted by the engine manufacturer.

Instructions for Obtaining Warranty Service

If you think that your Toro Product contains a defect in materials or workmanship, follow this procedure:

1. Contact any Authorized Toro Compact Utility Equipment (CUE) Service Dealer to arrange service at their dealership. To locate a dealer convenient to you, access our website at www.Toro.com. You may also call our Toro Customer Care Department toll free at the number below.
2. Bring the product and your proof of purchase (sales receipt) to the Service Dealer.
3. If for any reason you are dissatisfied with the Service Dealer's analysis or with the assistance provided, contact us at:

SWS Customer Care Department
Toro Warranty Company
8111 Lyndale Avenue South
Bloomington, MN 55420-1196
Toll Free: 888-384-9940

Owner Responsibilities

You must maintain your Toro Product by following the maintenance procedures described in the *Operator's Manual*. Such routine maintenance, whether performed by a dealer or by you, is at your expense. Parts scheduled for replacement as required maintenance ("Maintenance Parts"), are warranted for the period of time up to the scheduled replacement time for that part. Failure to perform required maintenance and adjustments can be grounds for disallowing a warranty claim.

Items and Conditions Not Covered

Not all product failures or malfunctions that occur during the warranty period are defects in materials or workmanship. This express warranty does not cover the following:

- Product failures which result from the use of non-Toro replacement parts, or from installation and use of add-on, modified, or unapproved accessories
- Product failures which result from failure to perform required maintenance and/or adjustments
- Product failures which result from operating the Product in an abusive, negligent or reckless manner
- Parts subject to consumption through use unless found to be defective. Examples of parts which are consumed, or used up, during normal product operation include, but are not limited to, belts, wipers, spark plugs, tires, filters, gaskets, wear plates, seals, O-rings, drive chains, clutches.
- Failures caused by outside influence. Items considered to be outside influence include, but are not limited to, weather, storage practices, contamination, use of unapproved coolants, lubricants, additives, or chemicals, etc.
- Normal "wear and tear" items. Normal "wear and tear" includes, but is not limited to, worn painted surfaces, scratched decals, etc.
- Repairs necessary due to failure to follow recommended fuel procedure (consult *Operator's Manual* for more details)
 - Removing contaminants from the fuel system is not covered
 - Use of old fuel (more than one month old) or fuel which contains more than 10% ethanol or more than 15% MTBE
 - Failure to drain the fuel system prior to any period of non-use over one month
- Any component covered by a separate manufacturer's warranty
- Pickup and delivery charges

General Conditions

Repair by an Authorized Toro Compact Utility Equipment (CUE) Service Dealer is your sole remedy under this warranty.

Neither The Toro Company nor Toro Warranty Company is liable for indirect, incidental or consequential damages in connection with the use of the Toro Products covered by this warranty, including any cost or expense of providing substitute equipment or service during reasonable periods of malfunction or non-use pending completion of repairs under this warranty. All implied warranties of merchantability and fitness for use are limited to the duration of this express warranty. Some states do not allow exclusions of incidental or consequential damages, or limitations on how long an implied warranty lasts, so the above exclusions and limitations may not apply to you.

This warranty gives you specific legal rights, and you may also have other rights which vary from state to state.

Except for the engine warranty coverage and the Emissions warranty referenced below, if applicable, there is no other express warranty. The Emissions Control System on your Product may be covered by a separate warranty meeting requirements established by the U.S. Environmental Protection Agency (EPA) or the California Air Resources Board (CARB). The hour limitations set forth above do not apply to the Emissions Control System Warranty. Refer to the California Emission Control Warranty Statement supplied with your Product or contained in the engine manufacturer's documentation for details.

Countries Other than the United States or Canada

Customers who have purchased Toro products outside the United States or Canada should contact their Toro Distributor (Dealer) to obtain guarantee policies for your country, province, or state. If for any reason you are dissatisfied with your Distributor's service or have difficulty obtaining guarantee information, contact the Toro importer. If all other remedies fail, you may contact us at Toro Warranty Company.

Australian Consumer Law: Australian customers will find details relating to the Australian Consumer Law either inside the box or at your local Toro Dealer.