



Count on it.

Parts Catalog

TimeMaster 76cm

Lawn Mower

Model No. 20975—Serial No. 315000001 and Up



Ordering Replacement Parts

To order replacement parts, please supply the part number, the quantity, and the description of each part desired.

Understanding Reference Numbers

Each identified part in an illustration has a reference number. The reference number for a part also appears in the parts list, along with other information about the part.

This catalog uses two special reference number formats, one to indicate parts in a service assembly and another to indicate the quantity of a given part in an illustration.

Service Assembly Reference Numbers

Parts in service assemblies have reference numbers in the form a:b. The a represents the reference number of the entire service assembly and the b represents a sequential number unique to each part within the service assembly.

For example, a wheel assembly might be identified by reference number 6, the tire by 6:1, the valve by 6:2, and the wheel by 6:3. When you order the assembly identified by reference number 6, you receive all parts identified by reference numbers 6:1, 6:2, and 6:3. However, you may also order any part individually. Reference numbers of this type appear in illustration and in parts lists.

Reference Numbers Indicating Quantity

In an illustration, if a reference number indicates more than one part, the reference number has the form nX y. The n represents the quantity of the part, the X is the multiplication symbol, and the y represents the reference number.

For example, in an illustration, the reference number 2X 37 means that two of the parts identified by reference number 37 are indicated.

List of Abbreviations

AR: as required

ASM: assembly

BBC: blade brake control

BHTF: button head thread forming

CARR: carriage

CCW: counter clockwise

CW: clockwise

DEG: degrees

DPA: Dual Point Adjustment

ECM: electronic control module

EXT: external

FH: flat head

GA: gauge

HD: heavy-duty

HF: hex flange

HH: hex head

HHF: hex head flange

HHFTF: hex head flange thread forming

HJ: hex jam

HLH: hex lag head

HOC: height-of-cut

HP: high pressure

HSBH: hex socket button head

HSFH: hex socket flat head

HSH: hex socket head

HWH: hex washer head

HWHTF: hex washer head thread forming

HYD: hydraulic

LH: left hand

LP: low pressure

LPG: Liquefied Petroleum Gas

NI: nylon insert

NPTF: national pipe thread fine

PFH: phillips flat head

PPH: phillips pan head

PPHTF: phillips pan head thread forming

PRH: phillips round head

PTH: phillips truss head

PTO: power-take-off

RH: right hand

ROPS: roll-over protection system

RRB: rear roller brush

SFH: slotted fillister head

SHH: slotted hex head

SHWH: slotted hex washer head

SPH: slotted pan head

SQH: square head

SRH: slotted round head

STD: standard

TAP: self tapping

TTH: torx truss head

Contents

Deck and Frame Assembly	4
Belt, Spindle and Blade Assembly	6
Side Discharge Chute Assembly	8
Bag Assembly	10
Engine and Pulley Assembly	12
Front Wheel and Axle Assembly	14
Transmission, Rear Wheel and Height-of-Cut Assembly	16
Handle Assembly	18
Attachments and Accessories	20

Deck and Frame Assembly

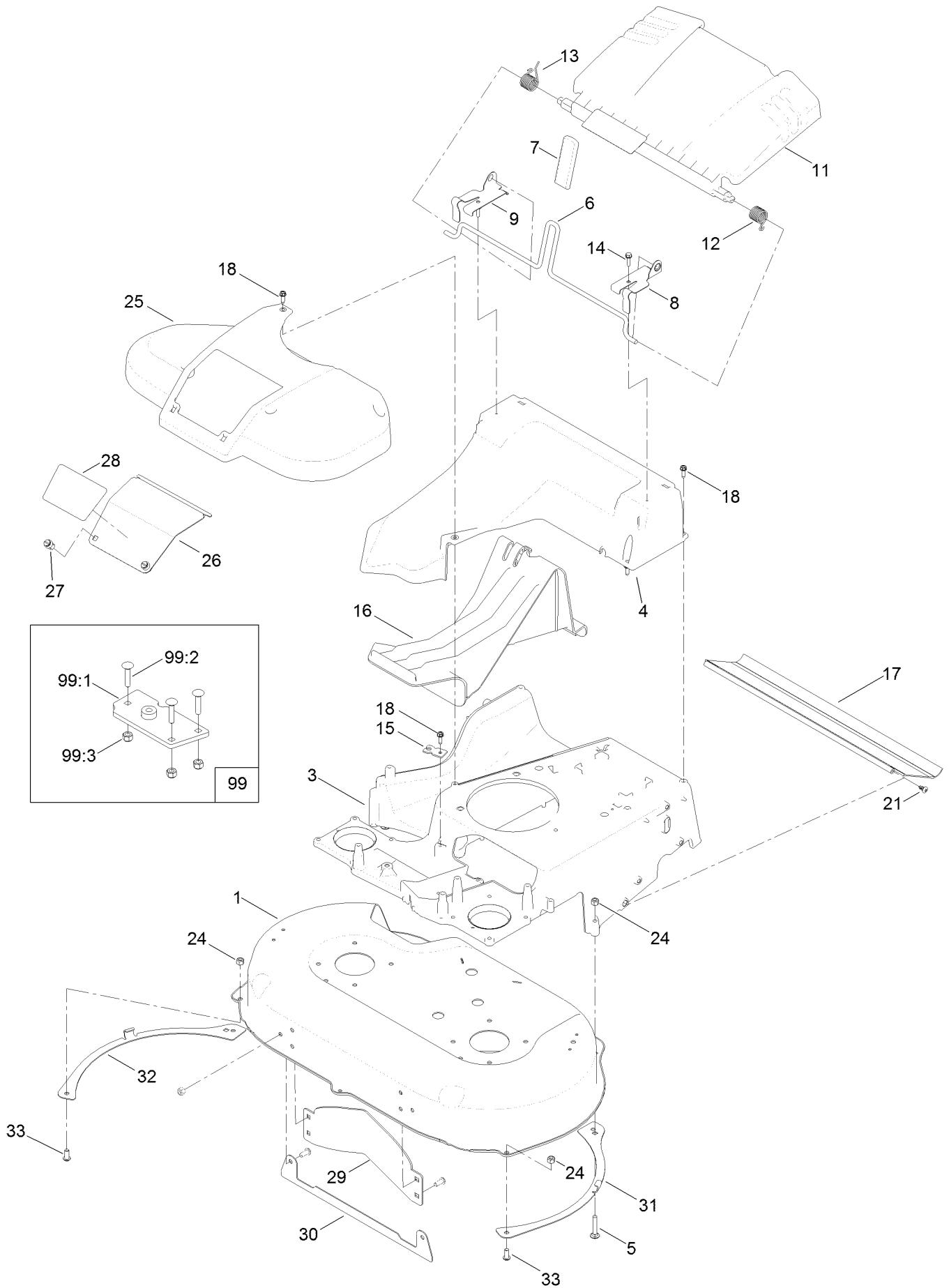

Deck and Frame Assembly (continued)

<i>Ref.</i>	<i>Part Number</i>	<i>Qty.</i>	<i>Description</i>	<i>Ref.</i>	<i>Part Number</i>	<i>Qty.</i>	<i>Description</i>
1	125-2534	1	Housing ASM	21	117-1092	2	Screw-PTH
3	121-9198-01	1	Frame	24	3296-29	4	Nut-Lock, NI
4	120-3336	1	Chute	25	121-5810	1	Cover-Belt
5	3230-5	2	Screw-CARR	26	121-5793-03	1	Door-Access
6	120-3344	1	Rod-Release, Handle	27	121-5840	2	Fastener
7	120-7018	1	Grip-Lever	28	125-2507	1	Decal-Access Panel
8	121-9114	1	Bracket-Door, LH	29	130-2352-01	1	Baffle-Control
9	121-9115	1	Bracket-Door, RH	30	125-5081-01	1	Plate-Deck
11	120-7048	1	Rear Deflector ASM	31	120-7085-03	1	Skid-LH
12	115-2859	1	Spring-Torsion	32	120-9488-03	1	Skid-RH
13	114-7924	1	Spring-Torsion	33	3274-55	2	Screw-HSBH
14	46-8091	2	Screw-HWH	99	125-5072	1	Frame Plate Kit (Service)
15	107-7497	1	Bracket-Cable, Traction	99:1	125-2542	1	Plate Frame ASM
16	120-5225	1	Plug-Mulch	99:2	3229-3	3	Screw-CARR
17	120-6241	1	Shield-Trailing	99:3	3296-42	3	Nut-Lock, NI
18	49-2040	9	Screw-HWHTF				

Belt, Spindle and Blade Assembly

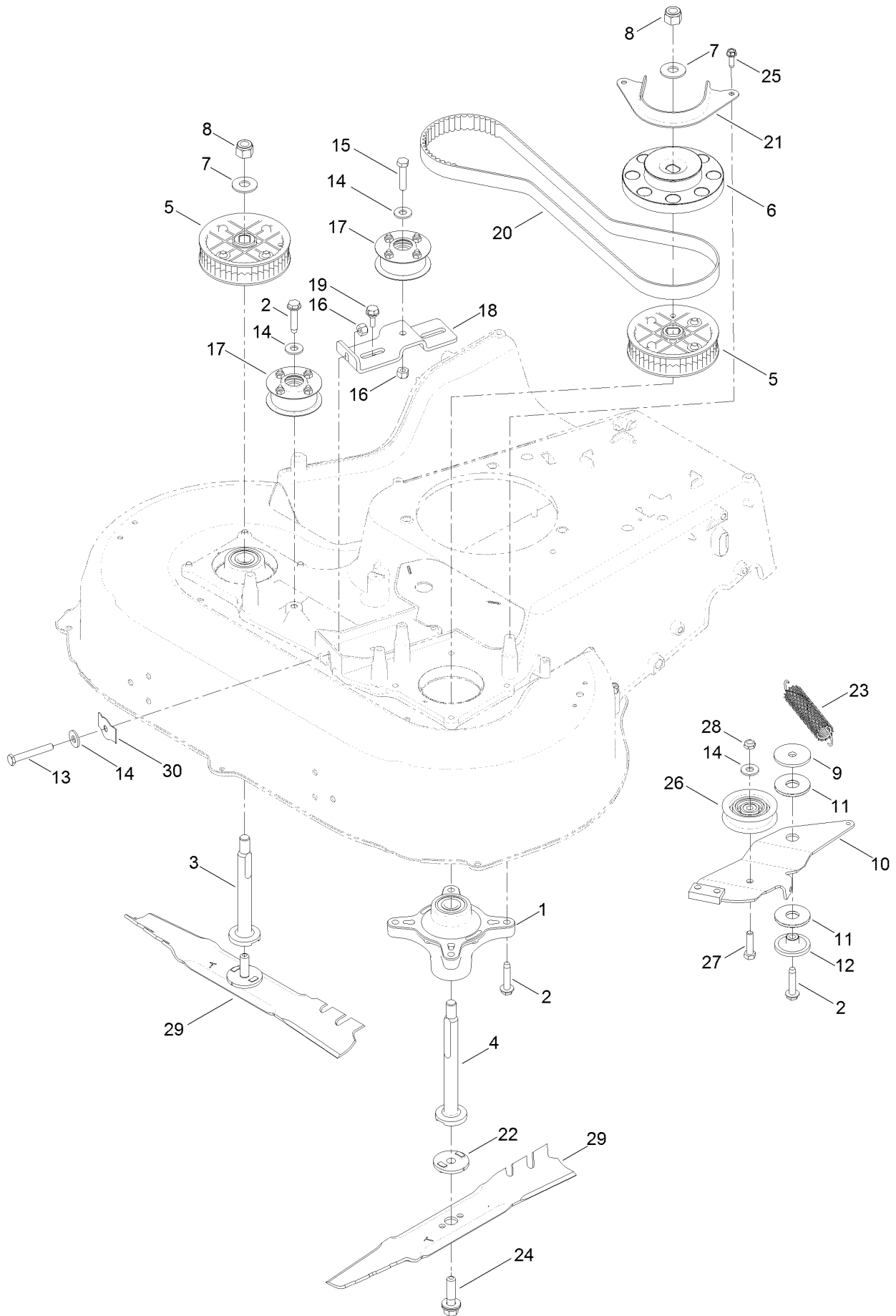

Belt, Spindle and Blade Assembly (continued)

<i>Ref.</i>	<i>Part Number</i>	<i>Qty.</i>	<i>Description</i>	<i>Ref.</i>	<i>Part Number</i>	<i>Qty.</i>	<i>Description</i>
1	121-9107	2	Spindle	16	3296-29	2	Nut-Lock, NI
2	32144-57	10	Screw	17	131-4509	2	Kit-Pulley
3	120-5234	1	Shaft-Spindle	18	120-3348	1	Bracket-Idler
4	120-5235	1	Shaft-Spindle	19	120-7024	2	Screw-Shoulder, HHF
5	121-9100	2	Sprocket	20	120-3335	1	Belt-Synchronous
6	130-6664	1	Pulley-Brake, Spindle	21	120-5245-03	1	Guide-Belt, Spindle
7	109-9505	2	Washer-Spring	22	120-5236	2	Adapter-Blade
8	3296-19	2	Nut-Hex	23	121-5808	1	Spring-Extension, Brake
9	63-7400	1	Washer-Rebound	24	125-2466	2	Bolt-Blade
10	120-6242	1	Arm-Brake	25	49-2040	2	Screw-HWHTF
11	121-2305	2	Washer-Friction, Composite	26	120-7082	1	Pulley-Idler
12	120-9490	1	Spacer	27	322-6	1	Screw-HH
13	9114524	1	Bolt-TAP, HH	28	3296-47	1	Nut-Lock, NI
14	3256-3	4	Washer-Flat	29	120-9500-03	2	Blade-Atomic, 15.4In
15	322-7	1	Screw-HH	30	121-2336	1	Spring-Flat

Side Discharge Chute Assembly

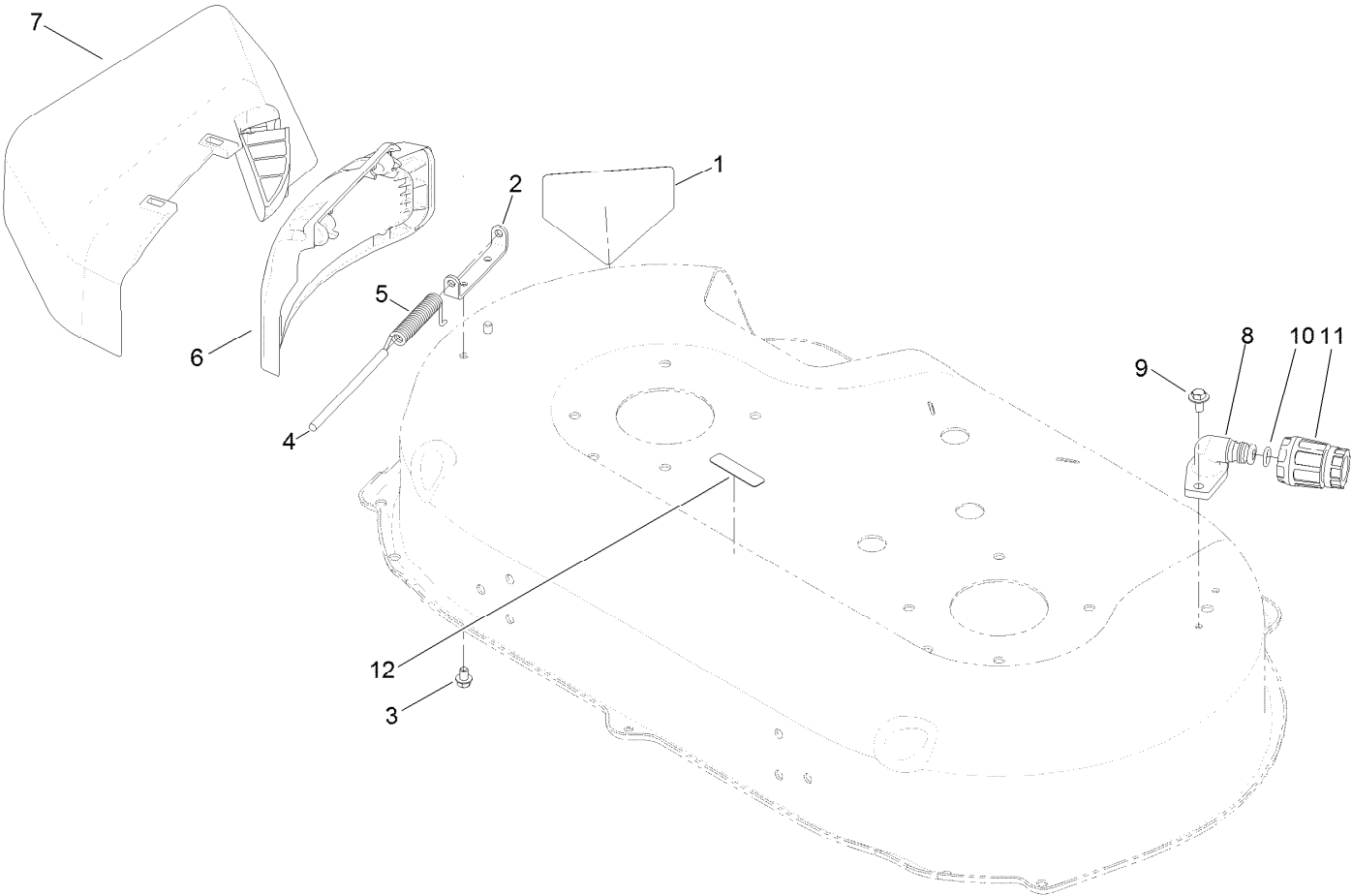

Side Discharge Chute Assembly (continued)

<i>Ref.</i>	<i>Part Number</i>	<i>Qty.</i>	<i>Description</i>	<i>Ref.</i>	<i>Part Number</i>	<i>Qty.</i>	<i>Description</i>
1	112-8760	1	Decal-Danger	7	127-6874	1	Side Discharge Chute ASM
2	112-6416	1	Bracket-Cover	8	95-2747	1	Fitting-Washout
3	99-8445	2	Screw-HWH	9	46-8560	2	Screw-HHFTF
4	99-5291	1	Rod-Cover	10	46-6290	1	O-Ring
5	127-0721	1	Spring-Torsion, Cover	11	95-3270	1	Connector-Hose
6	125-5091	1	Deflector-Side	12	120-9570	1	Decal-Warning

Bag Assembly

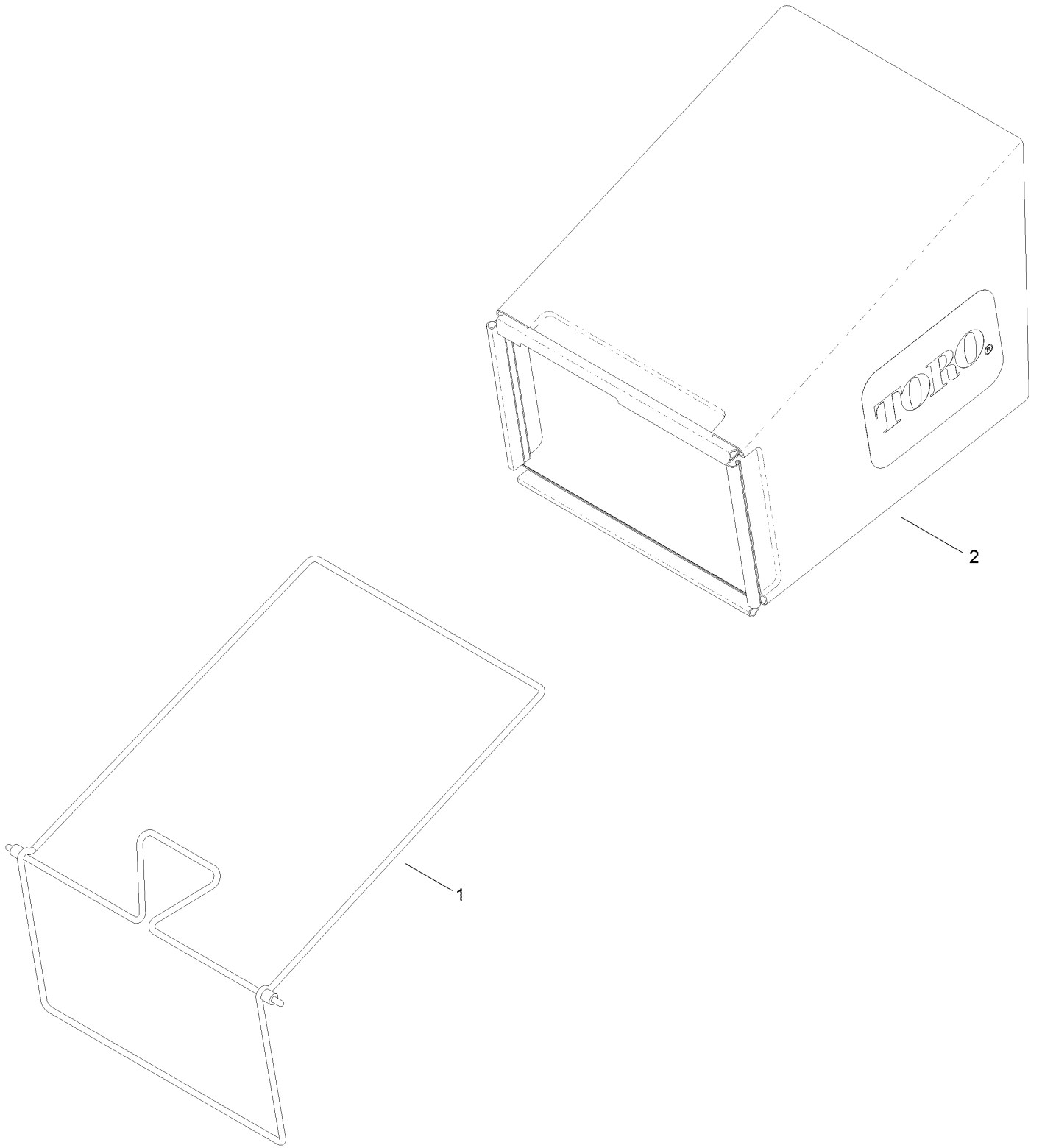

Bag Assembly (continued)

<i>Ref.</i>	<i>Part Number</i>	<i>Qty.</i>	<i>Description</i>
1	121-5766-03	1	Frame-Bag
2	121-5770	1	Bag-Grass

Engine and Pulley Assembly

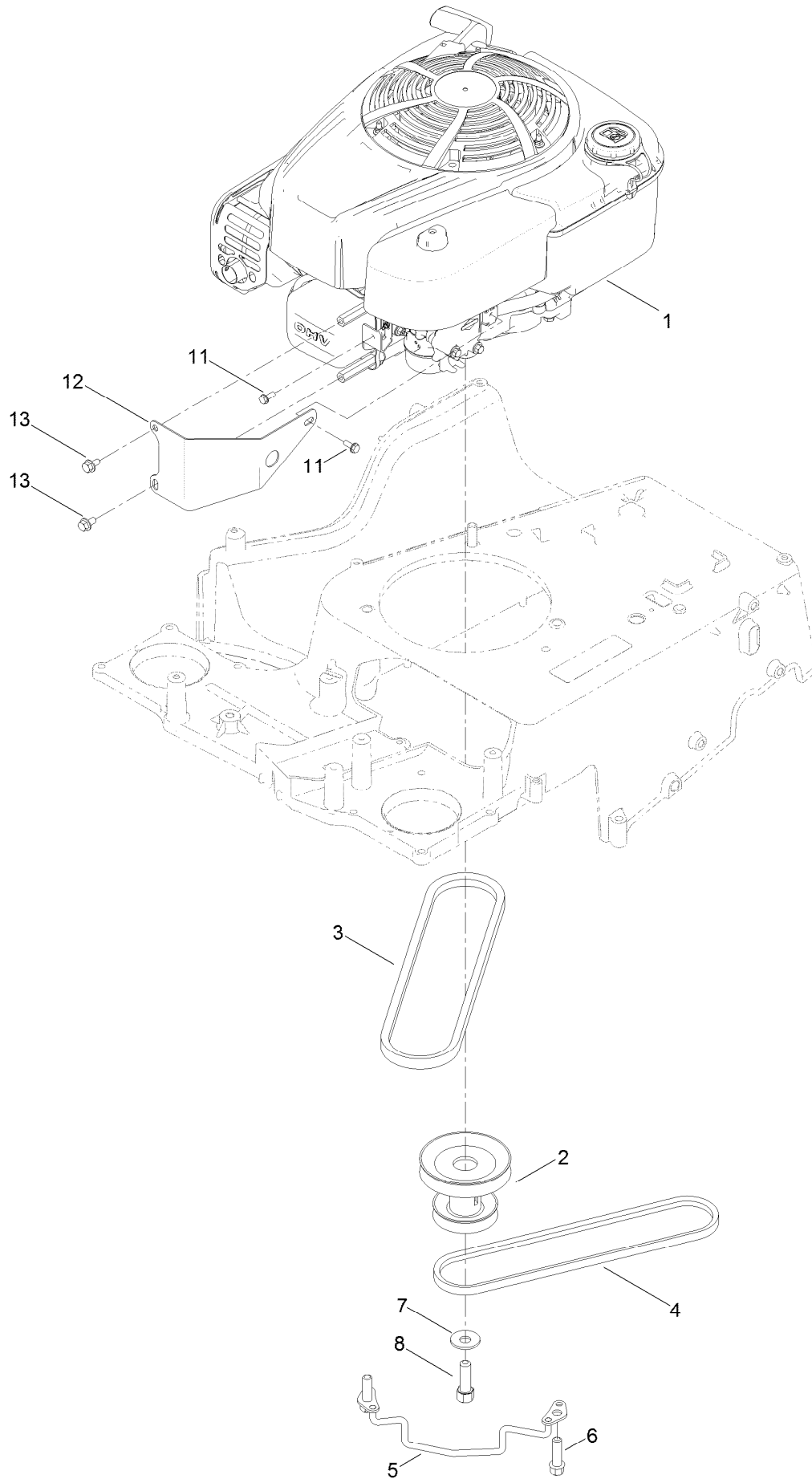

Engine and Pulley Assembly (continued)

<i>Ref.</i>	<i>Part Number</i>	<i>Qty.</i>	<i>Description</i>	<i>Ref.</i>	<i>Part Number</i>	<i>Qty.</i>	<i>Description</i>
1		1	Engine-Briggs, 121S020001F1 ●■	6	95-1727	3	Screw-Taptite
2	120-3333	1	Pulley-Engine	7	3290-465	1	Washer-Belleville
3	121-5765	1	V-Belt	8	26-0671	1	Screw-HH
4	120-9470	1	V-Belt, Traction	11	32144-2	2	Screw-Taptite
5	120-7077	1	Guide-Belt	12	131-0889-03	1	Guard-Engine
				13	126-2713	2	Screw-HHF

● Not serviced separately

■ Obtain parts from www.briggsandstratton.com

Front Wheel and Axle Assembly

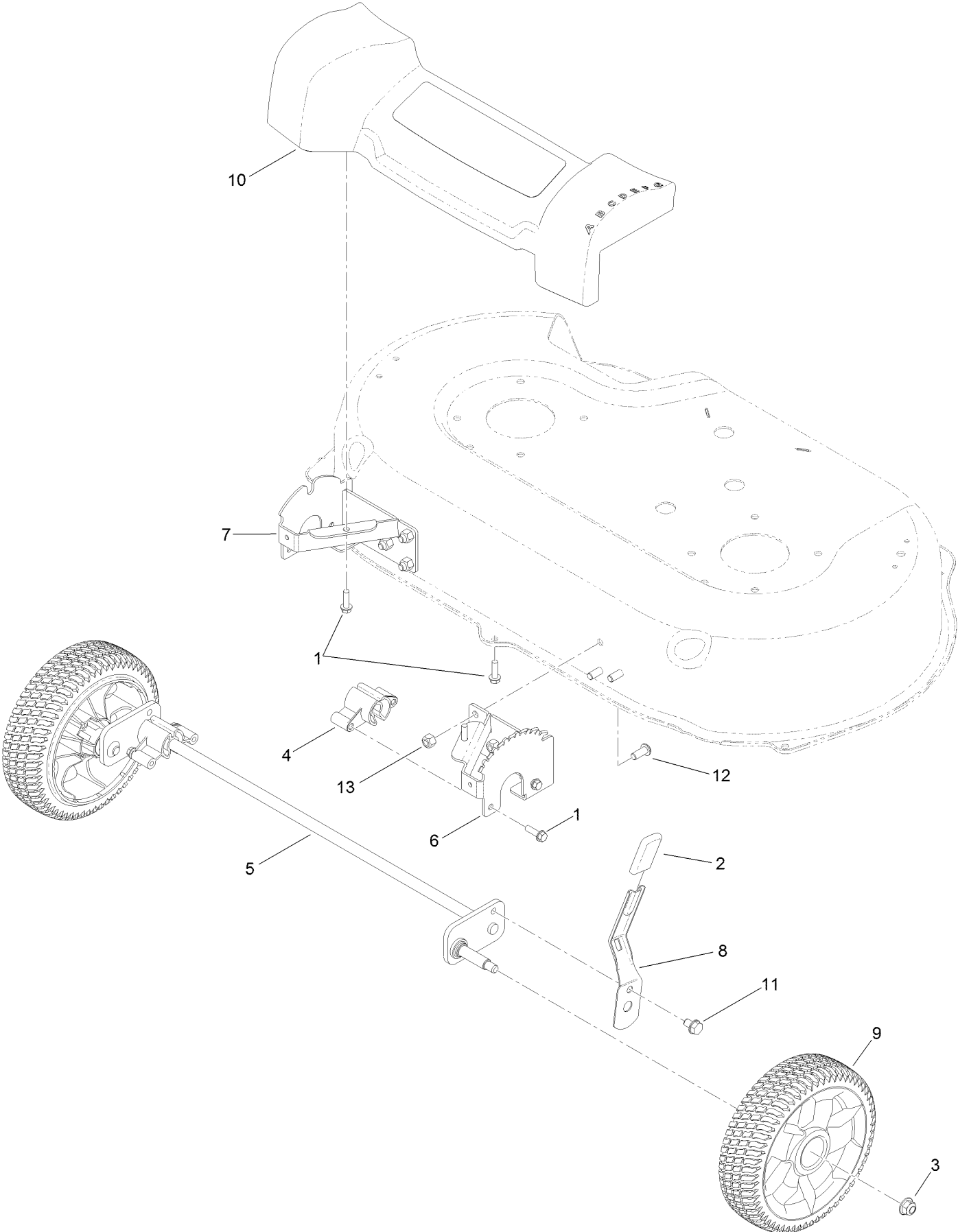

Front Wheel and Axle Assembly (continued)

<i>Ref.</i>	<i>Part Number</i>	<i>Qty.</i>	<i>Description</i>	<i>Ref.</i>	<i>Part Number</i>	<i>Qty.</i>	<i>Description</i>
1	46-8091	7	Screw-HWH	8	120-7043	1	Arm-Spring
2	120-9535	1	Grip-Lever	9	125-2510	2	8 Inch Wheel ASM
3	104-8301	2	Nut-Flange, NI	10	125-5027	1	Front Cover ASM
4	125-2495	2	Bushing-Pivot, Front	11	700057	1	Screw-HWH
5	131-0814	1	Axle-Front	12	3274-55	6	Screw-HSBH
6	120-7037-03	1	Plate-HOC, LH	13	3296-29	6	Nut-Lock, NI
7	120-7038-03	1	Plate-HOC, RH				

Transmission, Rear Wheel and Height-of-Cut Assembly

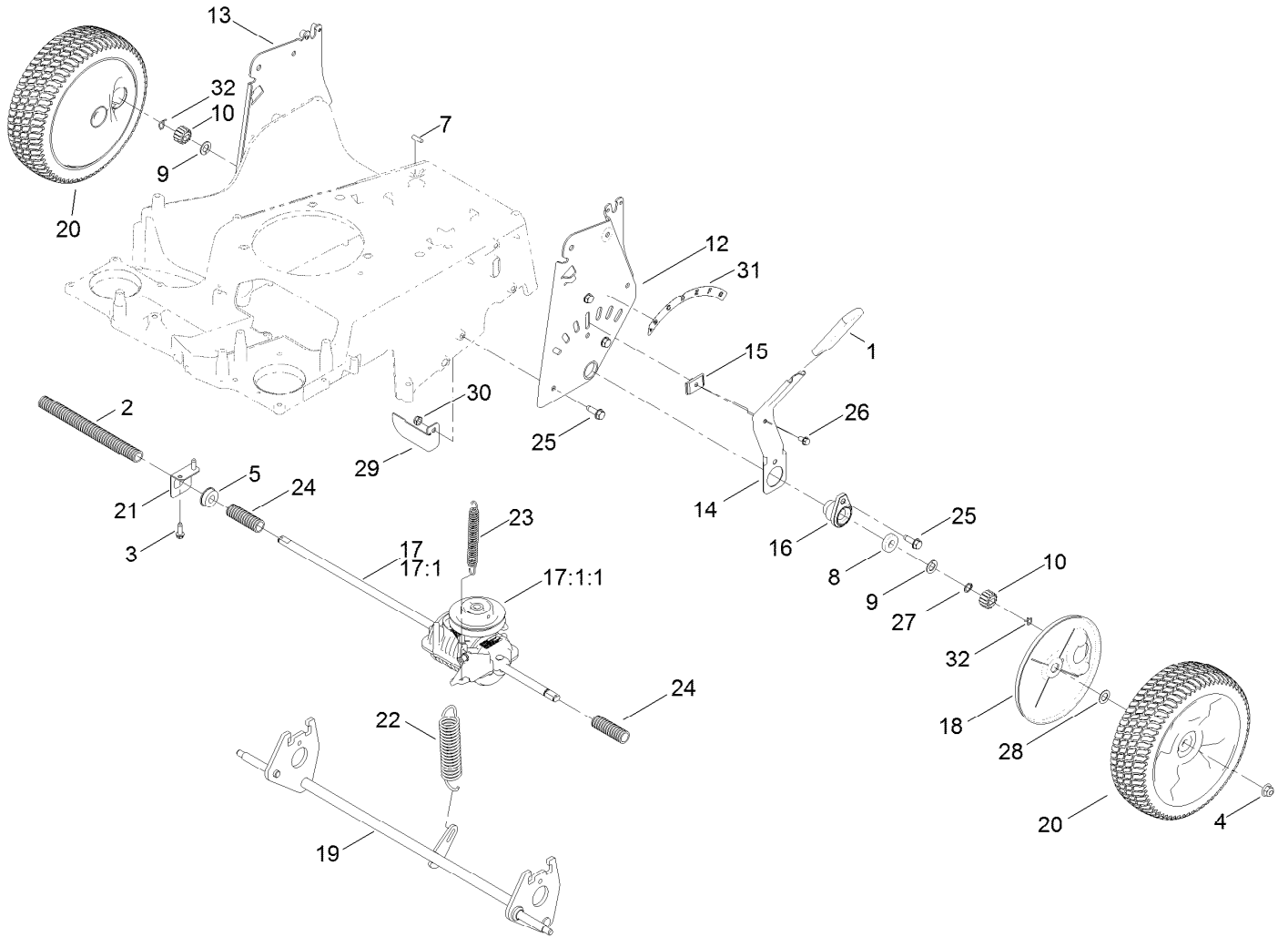

Transmission, Rear Wheel and Height-of-Cut Asseembly (continued)

<i>Ref.</i>	<i>Part Number</i>	<i>Qty.</i>	<i>Description</i>	<i>Ref.</i>	<i>Part Number</i>	<i>Qty.</i>	<i>Description</i>
1	1-633295	1	Grip-Lever, Lift	17:1:1	130-2370	1	Transmission Pulley Kit
2	121-5799	1	Conduit-Convolutd	18	120-6233	2	Cover-Gear
3	49-2040	2	Screw-HWHTF	19	131-0815	1	Axle-Rear
4	104-8301	2	Nut-Flange, NI	20	125-2509	2	10 Inch Wheel Gear ASM
5	104-8699	1	Bearing-Ball	21	120-7008	1	Mount-Bearing
7	106-5681	1	Pin-Stop	22	120-7026	1	Spring-Extension
8	109-8020	2	Bearing-Ball	23	120-7027	1	Spring-Extension
9	110-7191	2	Washer-Thrust	24	121-5800	2	Conduit-Convolutd
10	110-9417	2	Gear-Pinion, 15T	25	701243	8	Screw-HWHTF
12	120-3342-03	1	Plate-HOC, LH	26	32144-4	1	Screw-HWH
13	120-3343-03	1	Plate-HOC, RH	27	32151-61	1	Ring-Retaining
14	120-5208	1	Arm-Spring, Rear	28	36-4780	2	Washer-Plain
15	120-5209	1	Key-Springarm	29	121-5821	1	Bracket-Stop
16	120-5210	2	Retainer-Bearing	30	3296-47	1	Nut-Lock, NI
17	130-6670	1	Transmission Kit	31	125-2497	1	Decal-HOC, Rear
17:1		1	Transmission-Mv502 ●	32	130-2369	2	Pin-Snap

● Not serviced separately

Handle Assembly

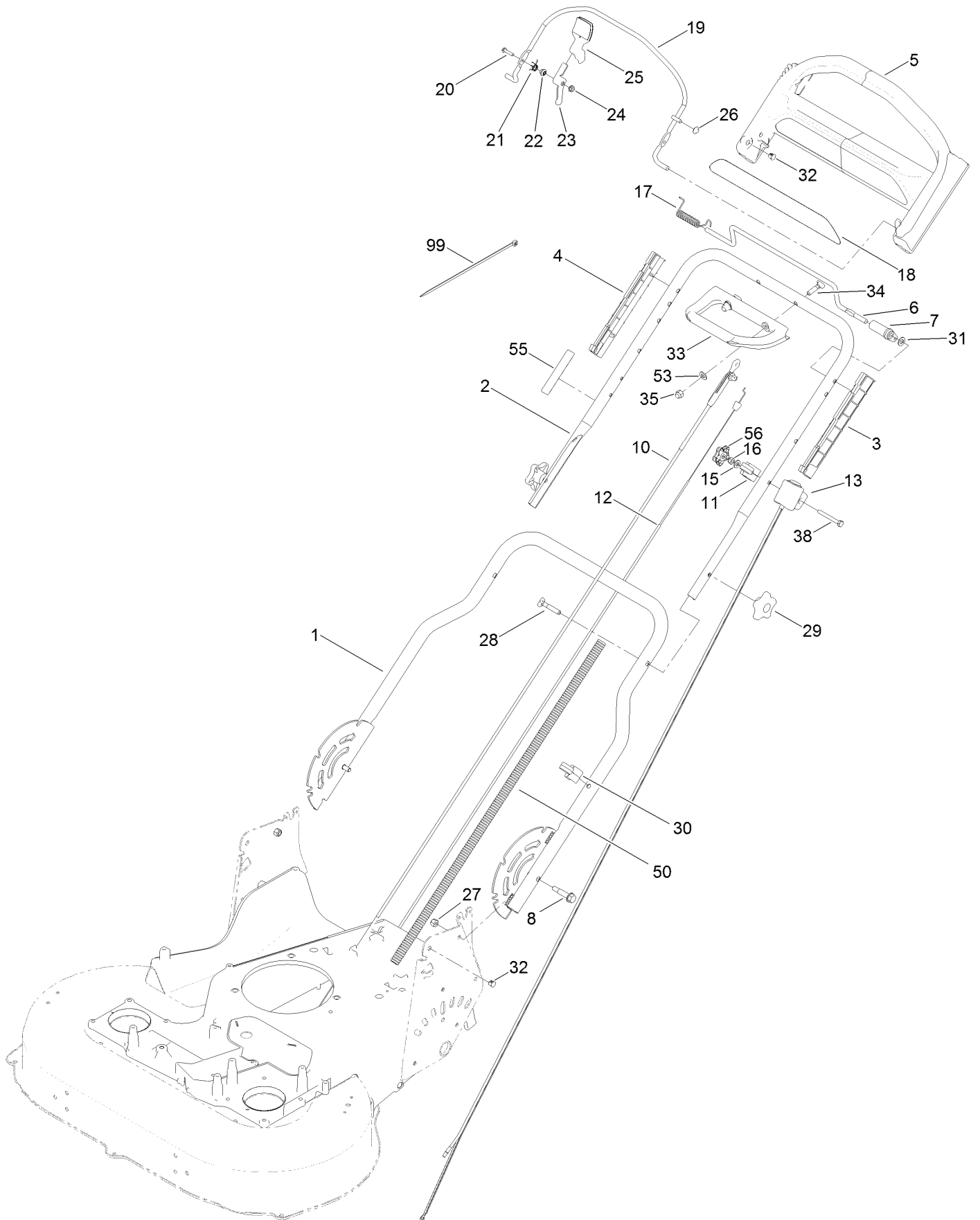

Handle Assembly (continued)

<i>Ref.</i>	<i>Part Number</i>	<i>Qty.</i>	<i>Description</i>	<i>Ref.</i>	<i>Part Number</i>	<i>Qty.</i>	<i>Description</i>
1	120-5204-05	1	Handle-Lower	23	106-6802	1	Lever
2	121-5783-05	1	Handle-Upper	24	32128-17	1	Nut-Lock, Flange
3	105-6842	1	Guide-LH	25	112-8884	1	Knob-BBC
4	105-6841	1	Guide-RH	26	3290-337	1	Nut-Speed
5	104-8678	1	Handle-Control	27	3296-29	2	Nut-Lock, NI
6	99-1588	1	Bar-Control, Traction	28	92-2260	2	Screw-Handle
7	127-6842	1	Lever-Traction	29	117-5976	2	Knob-Handle
8	120-7025	2	Bolt-Shoulder, HHF	30	114-7988	1	Guide-Cable
10	120-6243	1	Cable-Brake, BBC	31	130-2343	1	Spacer
11	99-5239	1	Anchor-Cable	32	104-9368	3	Plug-Dome
12	127-6867	1	Cable-Traction, Rwd	33	120-7087	1	Handle-Assist, Traction
13	117-5975	1	Switch Housing ASM	34	130-2356	2	Screw-Handle, Lock
15	3256-1	1	Washer-Flat	35	130-2341	2	Nut-Acorn
16	3296-73	1	Nut-Lock, NI	38	321-50	1	Screw-HH
17	121-9118	1	Spring-Torsion	50	121-5801	1	Conduit-Convolute
18	120-3911	1	Decal-Handle	53	3256-23	2	Washer-Flat
19	108-3788-03	1	Bail-Brake	55	131-0894	1	Decal-Traction, Adjust
20	106-9169	1	Screw-HWH	56	131-0897	1	Knob-Handle, Locking
21	107-7462	1	Spring-Torsion	99	614249	2	Tie-Cable
22	107-7463	1	Spacer				

Attachments and Accessories

For 20975 TimeMaster 76cm Lawn Mower

Product Name	Model/Part
Replacement Blade Kit	20120P
Lawn Striping Kit with 30in Roller.....	20602
Mower Cover	490-7461

Notes:

Notes:

Notes:



Count on it.