



**Count on it.**

**Parts Catalog**

**30in TurfMaster Walk-Behind  
Lawn Mower**

Model No. 22200—Serial No. 315000001 and Up



# Ordering Replacement Parts

To order replacement parts, please supply the part number, the quantity, and the description of each part desired.

## Understanding Reference Numbers

Each identified part in an illustration has a reference number. The reference number for a part also appears in the parts list, along with other information about the part.

This catalog uses two special reference number formats, one to indicate parts in a service assembly and another to indicate the quantity of a given part in an illustration.

## Service Assembly Reference Numbers

Parts in service assemblies have reference numbers in the form a:b. The a represents the reference number of the entire service assembly and the b represents a sequential number unique to each part within the service assembly.

For example, a wheel assembly might be identified by reference number 6, the tire by 6:1, the valve by 6:2, and the wheel by 6:3. When you order the assembly identified by reference number 6, you receive all parts identified by reference numbers 6:1, 6:2, and 6:3. However, you may also order any part individually. Reference numbers of this type appear in illustration and in parts lists.

## Reference Numbers Indicating Quantity

In an illustration, if a reference number indicates more than one part, the reference number has the form nX y. The n represents the quantity of the part, the X is the multiplication symbol, and the y represents the reference number.

For example, in an illustration, the reference number 2X 37 means that two of the parts identified by reference number 37 are indicated.

# List of Abbreviations

**AR:** as required

**ASM:** assembly

**BBC:** blade brake control

**BHTF:** button head thread forming

**CARR:** carriage

**CCW:** counter clockwise

**CW:** clockwise

**DEG:** degrees

**DPA:** Dual Point Adjustment

**ECM:** electronic control module

**EXT:** external

**FH:** flat head

**GA:** gauge

**HD:** heavy-duty

**HF:** hex flange

**HH:** hex head

**HHF:** hex head flange

**HHFTF:** hex head flange thread forming

**HJ:** hex jam

**HLH:** hex lag head

**HOC:** height-of-cut

**HP:** high pressure

**HSBH:** hex socket button head

**HSFH:** hex socket flat head

**HSH:** hex socket head

**HWH:** hex washer head

**HWHTF:** hex washer head thread forming

**HYD:** hydraulic

**LH:** left hand

**LP:** low pressure

**LPG:** Liquefied Petroleum Gas

**NI:** nylon insert

**NPTF:** national pipe thread fine

**PFH:** phillips flat head

**PPH:** phillips pan head

**PPHTF:** phillips pan head thread forming

**PRH:** phillips round head

**PTH:** phillips truss head

**PTO:** power-take-off

**RH:** right hand

**ROPS:** roll-over protection system

**RRB:** rear roller brush

**SFH:** slotted fillister head

**SHH:** slotted hex head

**SHWH:** slotted hex washer head

**SPH:** slotted pan head

**SQH:** square head

**SRH:** slotted round head

**STD:** standard

**TAP:** self tapping

**TTH:** torx truss head

# Contents

Deck, Frame and Chute Assembly .....	4
Spindle and Blade Assembly .....	6
Side Discharge Chute Assembly .....	8
Grass Bag Assembly .....	10
Engine and Fuel Tank Assembly .....	12
Front Bumper and Wheel Assembly .....	14
Traction and Height-of-Cut Assembly .....	16
Handle Assembly .....	18
Attachments and Accessories .....	20

# Deck, Frame and Chute Assembly

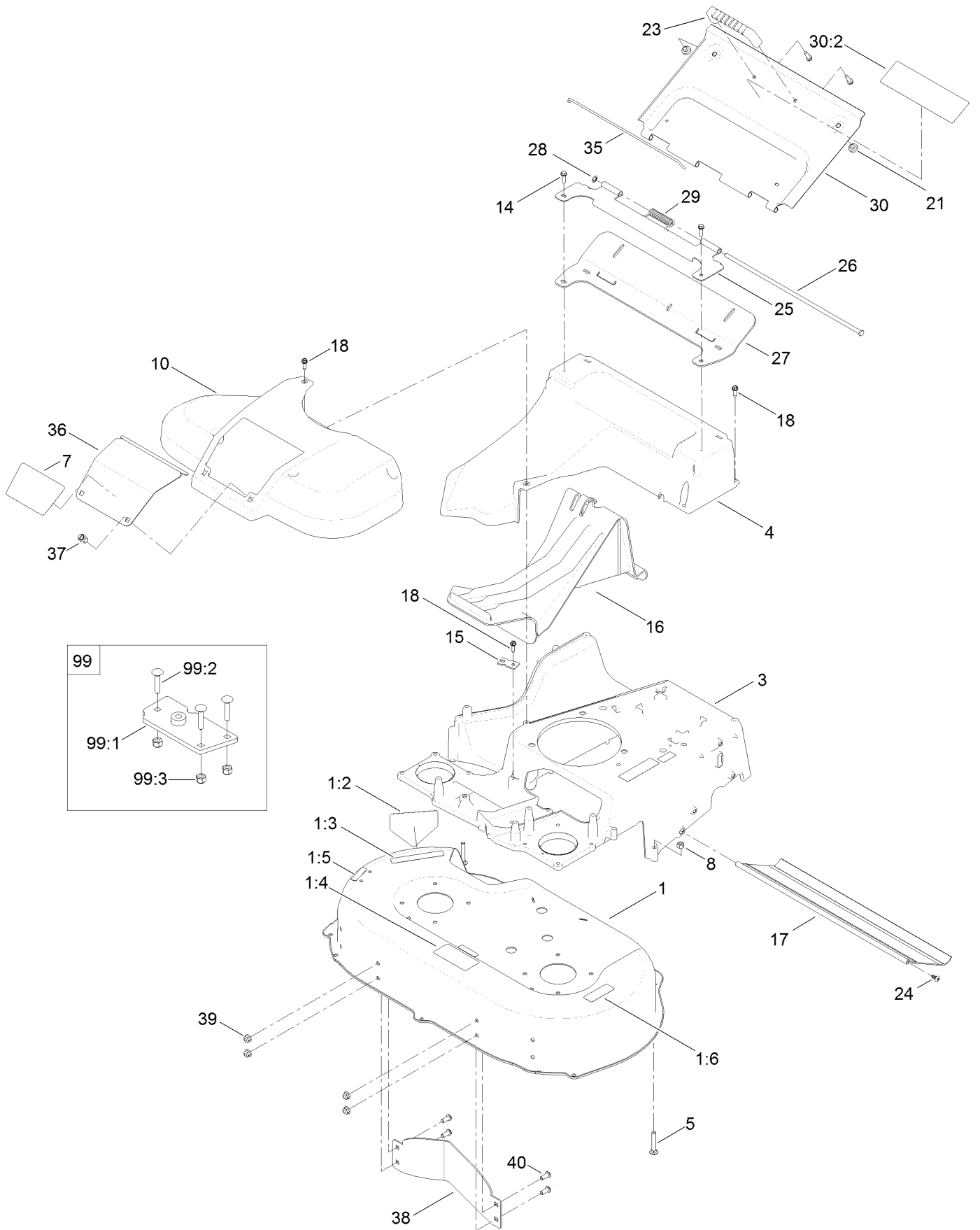

## Deck, Frame and Chute Assembly (continued)

<i>Ref.</i>	<i>Part Number</i>	<i>Qty.</i>	<i>Description</i>	<i>Ref.</i>	<i>Part Number</i>	<i>Qty.</i>	<i>Description</i>
1	131-4543	1	Deck-30 Inch	24	117-1092	2	Screw-PTH
1:2	94-8072	1	Decal-Danger	25	116-6351-03	1	Bracket-Hinge
1:3	93-7009	1	Decal-Danger	26	116-6933	1	Pin-Hinge
1:4	116-8528	1	Decal	27	116-6229	1	Seal-Door
1:5	120-9570	2	Decal-Warning	28	32151-72	1	Ring-Retaining
1:6	121-1449	1	Decal-Warning, Block	29	116-7573	1	Spring-Torsion, Cover
3	127-6859-01	1	Frame	30	116-8355	1	Rear Door ASM
4	120-3336	1	Chute	30:2	116-7583	1	Decal-Warning
5	127-6841	2	Screw-CARR	35	116-6966	1	Clip-Seal
7	121-9191	1	Decal	36	121-5793-03	1	Door-Access
8	3296-29	2	Nut-Lock, NI	37	121-5840	2	Fastener
10	121-5810	1	Cover-Belt	38	130-2352-01	1	Baffle-Control
14	46-8091	4	Screw-HWH	39	104-8300	4	Nut-Flange, NI
15	107-7497	1	Bracket-Cable, Traction	40	3274-55	4	Screw-HSBH
16	120-5225	1	Plug-Mulch	99	125-5072	1	Frame Plate Kit (Service)
17	121-5841	1	Shield-Trailing	99:1	125-2542	1	Plate Frame ASM
18	49-2040	9	Screw-HWHTF	99:2	3229-3	3	Screw-CARR
21	1-513658	2	Bumper	99:3	3296-42	3	Nut-Lock, NI
23	65-5100	1	Handle-Door				

# Spindle and Blade Assembly

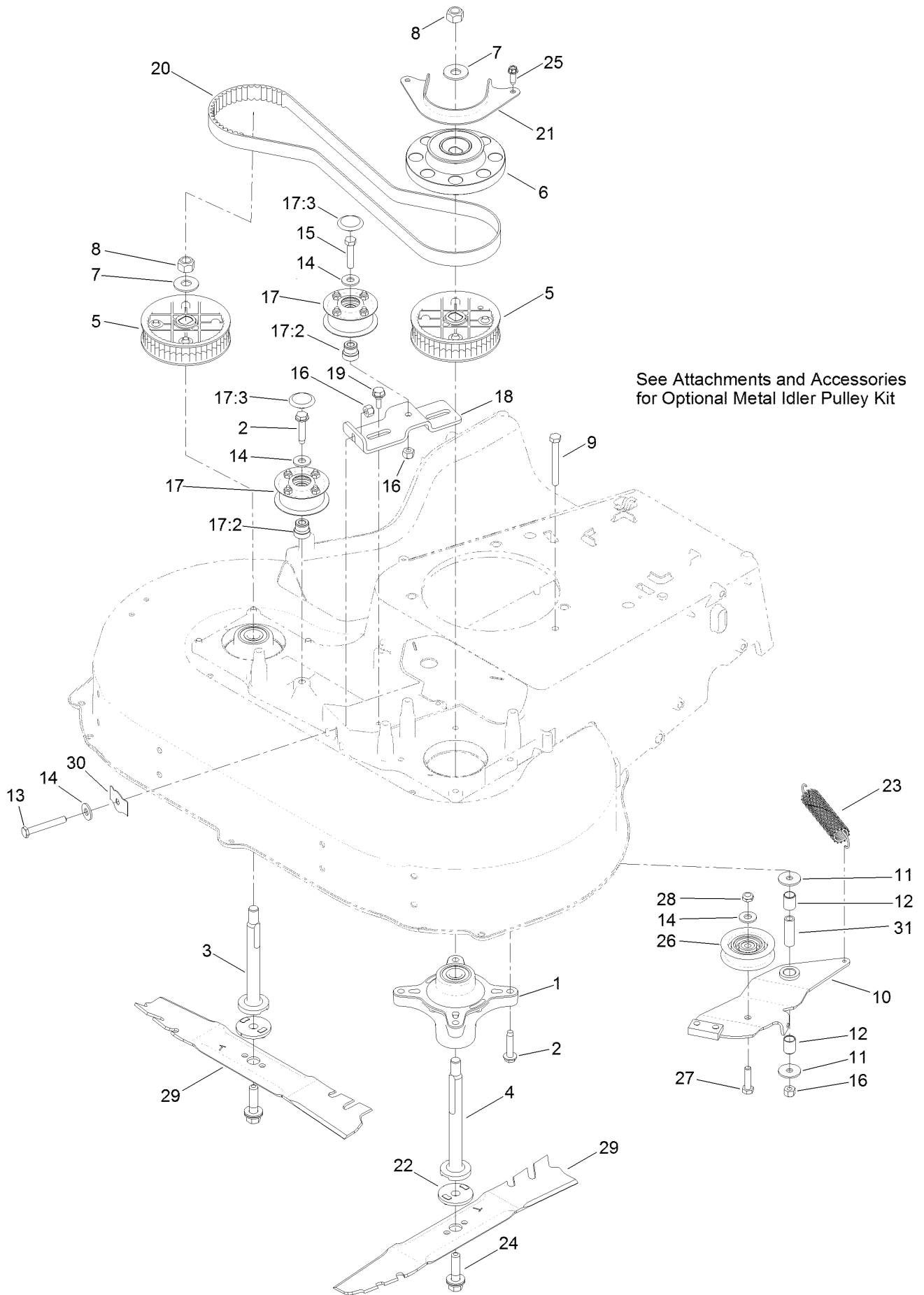

## Spindle and Blade Assembly (continued)

<i>Ref.</i>	<i>Part Number</i>	<i>Qty.</i>	<i>Description</i>	<i>Ref.</i>	<i>Part Number</i>	<i>Qty.</i>	<i>Description</i>
1	120-6234	2	Spindle ASM	17:2	131-4504	1	Adapter-Bore
2	32144-57	9	Screw	17:3	125-2533	1	Plug-Cap
3	120-5234	1	Shaft-Spindle	18	120-3348	1	Bracket-Idler
4	120-5235	1	Shaft-Spindle	19	120-7024	2	Screw-Shoulder, HHF
5	121-9100	2	Sprocket	20	120-3335	1	Belt-Synchronous
6	130-6664	1	Pulley-Brake, Spindle	21	120-5245-03	1	Guide-Belt, Spindle
7	109-9505	2	Washer-Spring	22	120-5236	2	Adapter-Blade
8	3296-19	2	Nut-Hex	23	121-5808	1	Spring-Extension, Brake
9	322-13	1	Screw-HH	24	125-2466	2	Bolt-Blade
10	121-5796	1	Brake Arm ASM	25	49-2040	2	Screw-HWHTF
11	5-4460	2	Washer-Pivot	26	120-7082	1	Pulley-Idler
12	131-0819	2	Bushing-Sleeve	27	322-6	1	Screw-HH
13	9114524	1	Bolt-TAP, HH	28	3296-47	1	Nut-Lock, NI
14	3256-3	4	Washer-Flat	29	116-6358-03	2	Blade-Rotary
15	322-7	1	Screw-HH	30	121-2336	1	Spring-Flat
16	3296-29	3	Nut-Lock, NI	31	131-0823	1	Spacer-Brake
17	131-4529	2	Pulley Kit				

# Side Discharge Chute Assembly

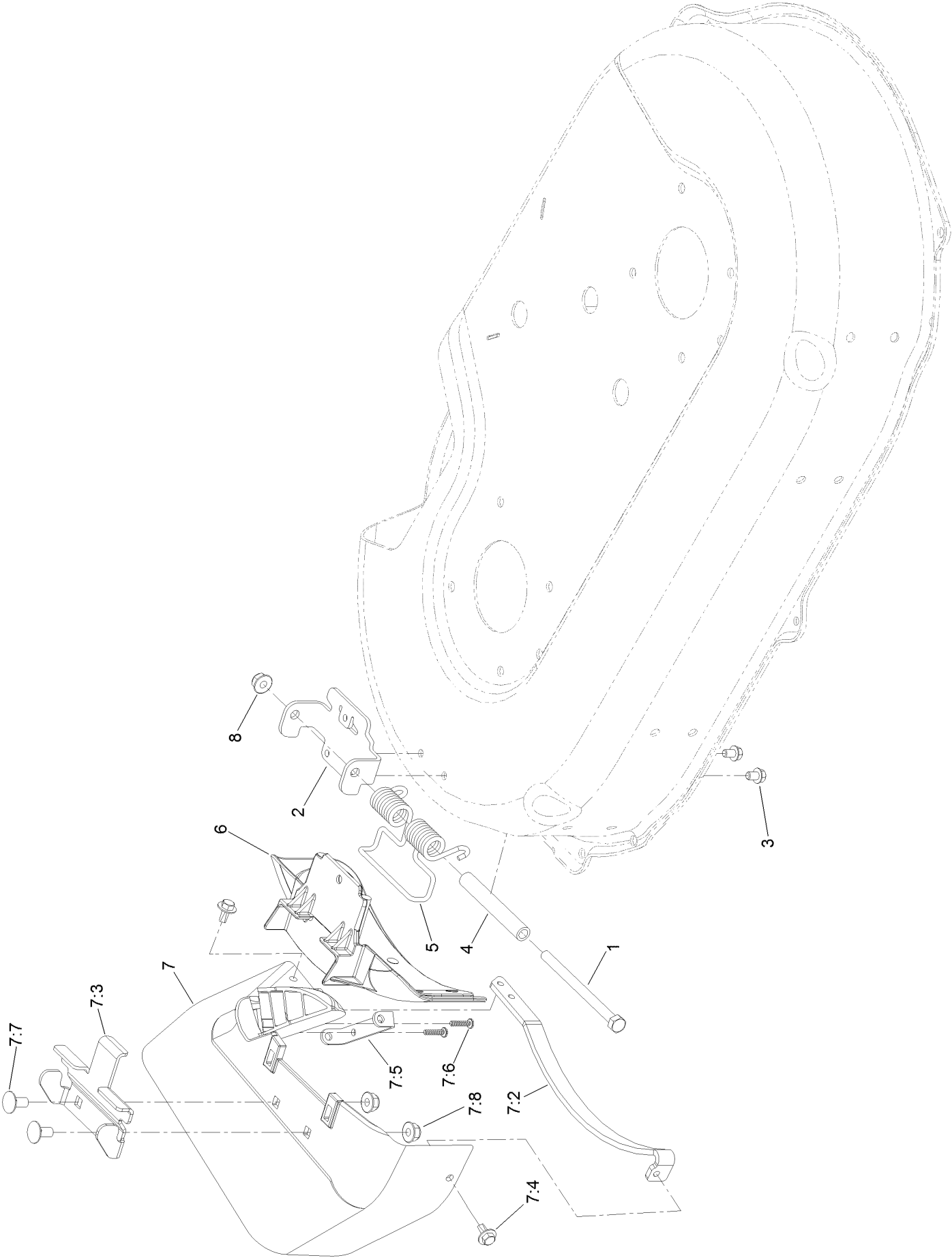



## Side Discharge Chute Assembly (continued)

<i>Ref.</i>	<i>Part Number</i>	<i>Qty.</i>	<i>Description</i>	<i>Ref.</i>	<i>Part Number</i>	<i>Qty.</i>	<i>Description</i>
1	322-38	1	Screw-HH	7:3	121-9196	1	Bracket-Chute
2	121-9195	1	Hinge	7:4	46-8560	2	Screw-HHFTF
3	99-8445	2	Screw-HWH	7:5	112-6416	1	Bracket-Cover
4	125-2478	1	Spacer	7:6	94-4496	2	Screw-PPH
5	121-9193	1	Spring-Torsion	7:7	3230-18	2	Screw-CARR
6	125-5093-01	1	Cover-Discharge	7:8	104-8300	2	Nut-Flange, NI
7	116-9754	1	Side Discharge Chute ASM	8	104-8300	1	Nut-Flange, NI
7:2	116-9752-03	1	Guard-Chute				

# Grass Bag Assembly

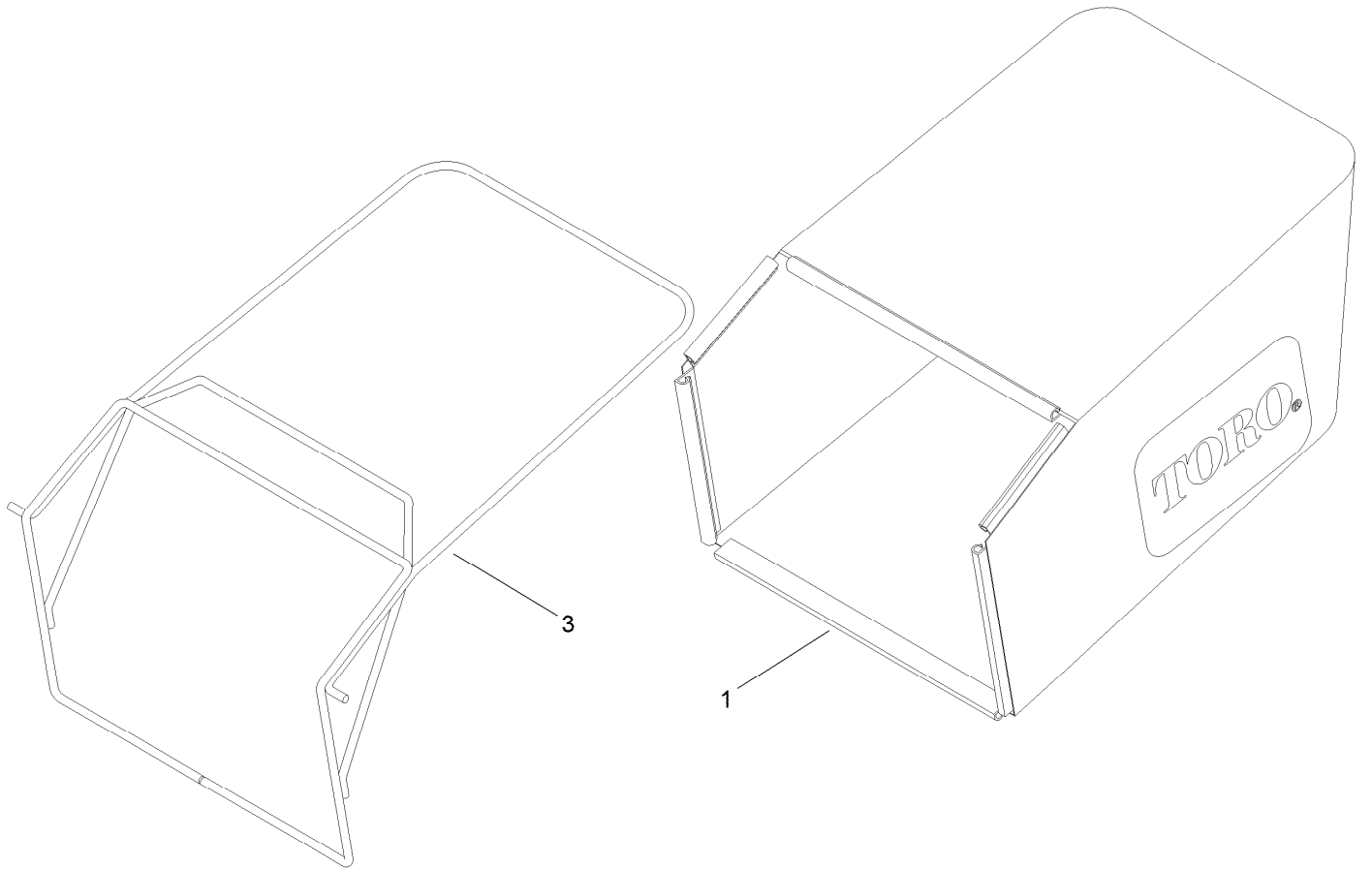

## Grass Bag Assembly (continued)

<i>Ref.</i>	<i>Part Number</i>	<i>Qty.</i>	<i>Description</i>
1	121-5775	1	Grass Bag ASM
3	116-5596-03	1	Frame-Bag

# Engine and Fuel Tank Assembly

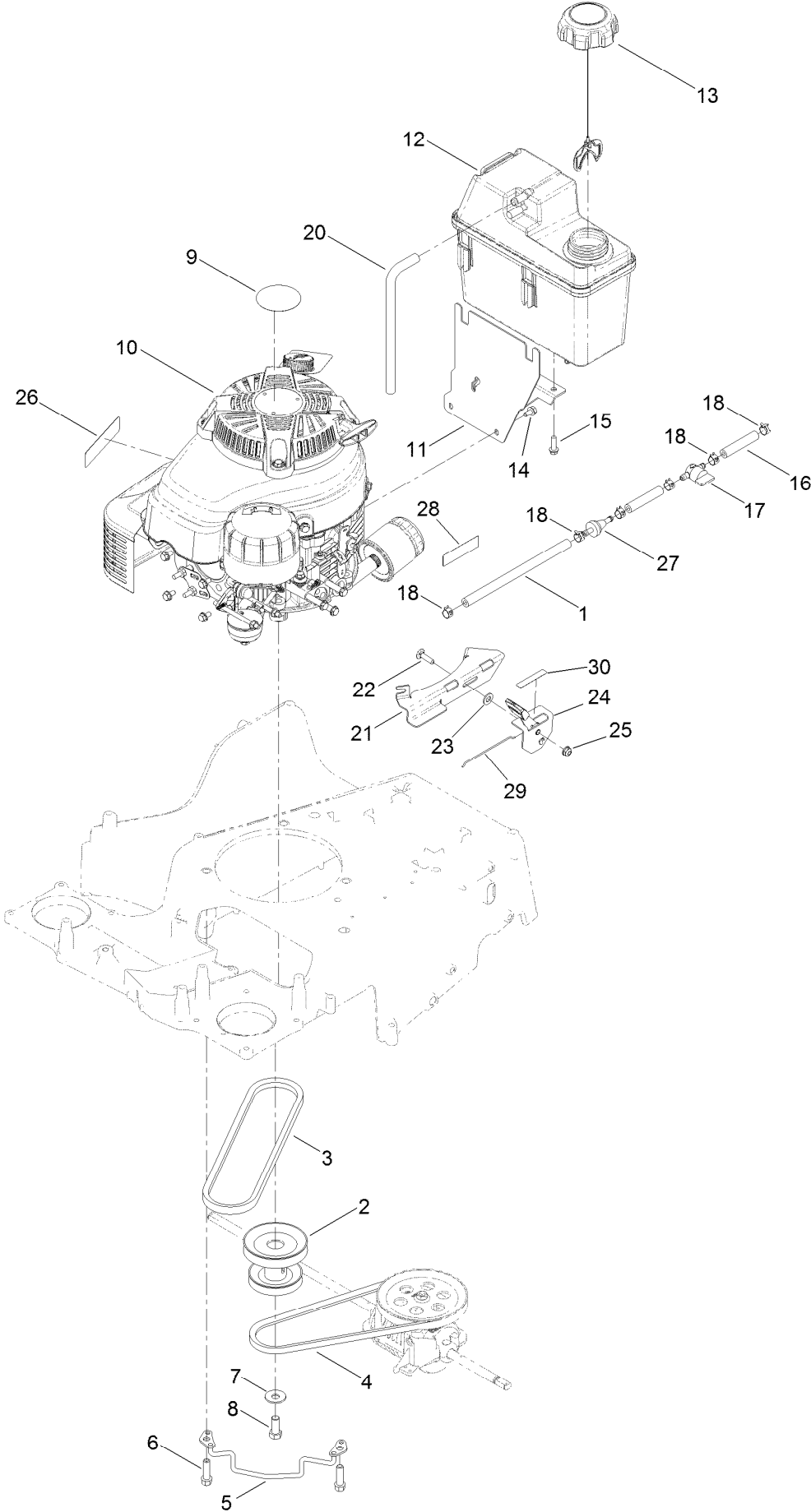

## Engine and Fuel Tank Assembly (continued)

<i>Ref.</i>	<i>Part Number</i>	<i>Qty.</i>	<i>Description</i>	<i>Ref.</i>	<i>Part Number</i>	<i>Qty.</i>	<i>Description</i>
1	119-1892	1	Hose-Fuel	16	109-0304	2	Hose-Fuel
2	116-7013	1	Pulley-Engine	17	1-603770	1	Valve-Fuel
3	121-5765	1	V-Belt	18	2412-98	6	Clamp-Hose
4	116-7116	1	Belt	20	115-0962	1	Hose-Vent, Canister
5	120-7077	1	Guide-Belt	21	130-6440-03	1	Bracket-Mount, Throttle
6	95-1727	3	Screw-Taptite	22	3229-30	1	Screw-CARR
7	3290-465	1	Washer-Belleville	23	3256-23	1	Washer-Flat
8	3212-4	1	Screw-HH	24	130-9655	1	Control-Throttle
9	109-6528	1	Decal-Recoil	25	104-7201	1	Nut-Flange, NI
10		1	Engine-Kawasaki Fj180V ●■	26	117-2718	1	Decal-Arrester, Spark
11	115-0954-03	1	Mount-Tank	27	71-9280	1	Filter-Fuel
12	125-5066	1	Tank-Fuel	28	116-9313	1	Decal-Warning, Engine
13	109-6776	1	Cap-Ratchet, Tethered	29	130-9654	1	Wire-Control
14	116-8929	3	Screw-HWH	30	130-9656	1	Decal-Throttle, Choke
15	46-8091	2	Screw-HWH				

● Not serviced separately

■ Obtain parts from [www.kawpowerepc.com](http://www.kawpowerepc.com)

# Front Bumper and Wheel Assembly

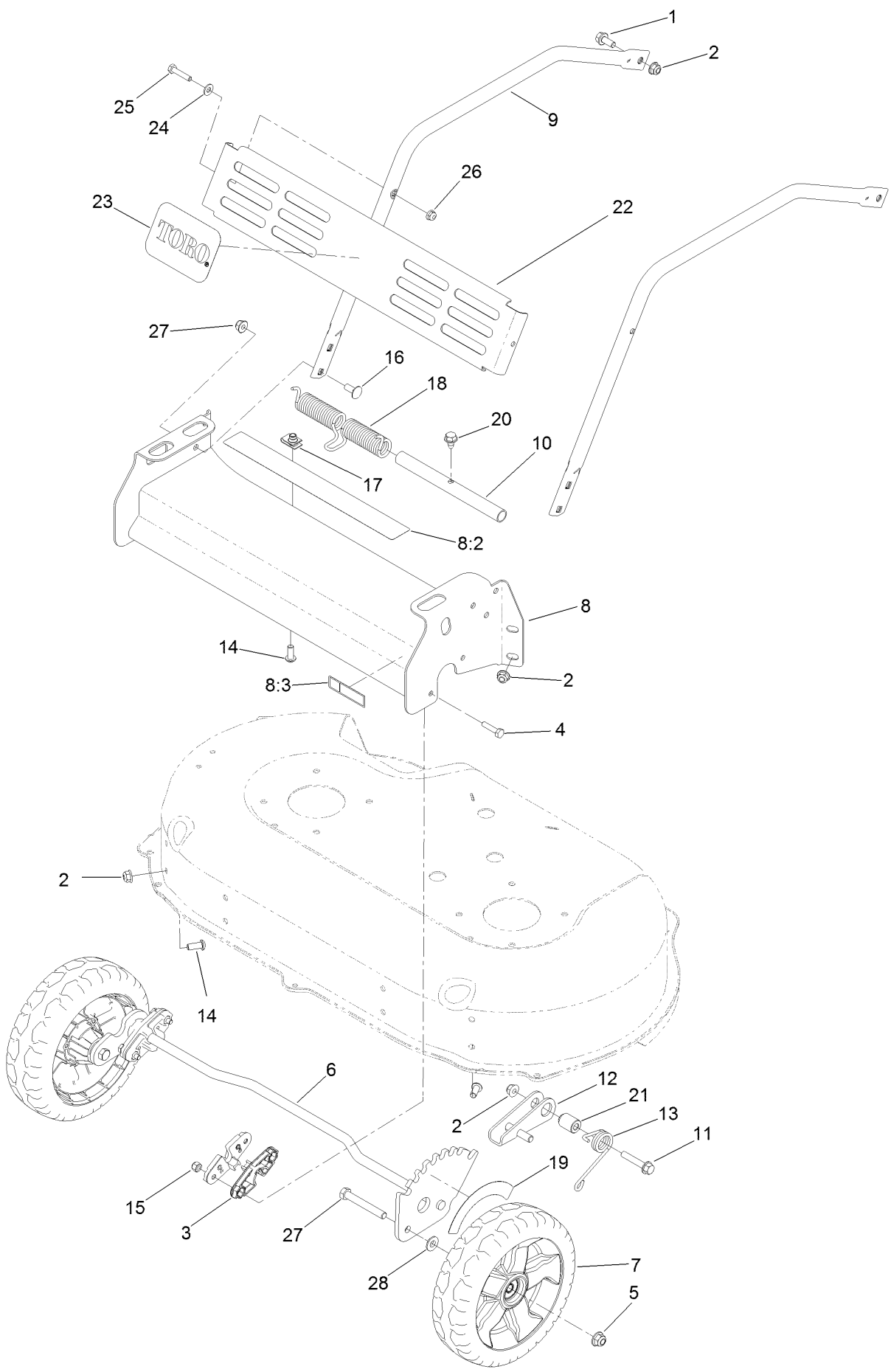

## Front Bumper and Wheel Assembly (continued)

<i>Ref.</i>	<i>Part Number</i>	<i>Qty.</i>	<i>Description</i>	<i>Ref.</i>	<i>Part Number</i>	<i>Qty.</i>	<i>Description</i>
1	116-7230	2	Screw-HHF	14	3274-55	5	Screw-HSBH
2	104-8300	11	Nut-Flange, NI	15	3296-42	4	Nut-Lock, NI
3	121-5781	4	Bushing-Front	16	3230-23	4	Screw-CARR
4	321-7	4	Screw-HH	17	94-2413	1	Nut-U
5	104-8301	2	Nut-Flange, NI	18	121-2337	1	Spring-Torsion
6	131-0826	1	Axle-Front	19	121-5846	1	Decal-HOC, Front
7	125-1080	2	Wheel	20	9266934	1	Screw
8	125-2488	1	Front Bumper ASM	21	125-2486	1	Spacer
8:2	121-5847	1	Decal	22	121-9187-03	1	Shield
8:3	116-7581	1	Decal-Warning	23	117-0871	1	Decal
9	121-9168-03	2	Brace	24	3256-22	2	Washer-Flat
10	121-5809	1	Mandrell-Spring	25	321-8	2	Screw-HH
11	94-5780	1	Screw-HWH	26	104-7201	2	Nut-Flange, NI
12	125-2483	1	Lock-Height, Adjustment	27	323-13	2	Screw-HH
13	120-9465	1	Spring-Torsion	28	74-1671	2	Spacer-Cover, Wheel

# Traction and Height-of-Cut Assembly

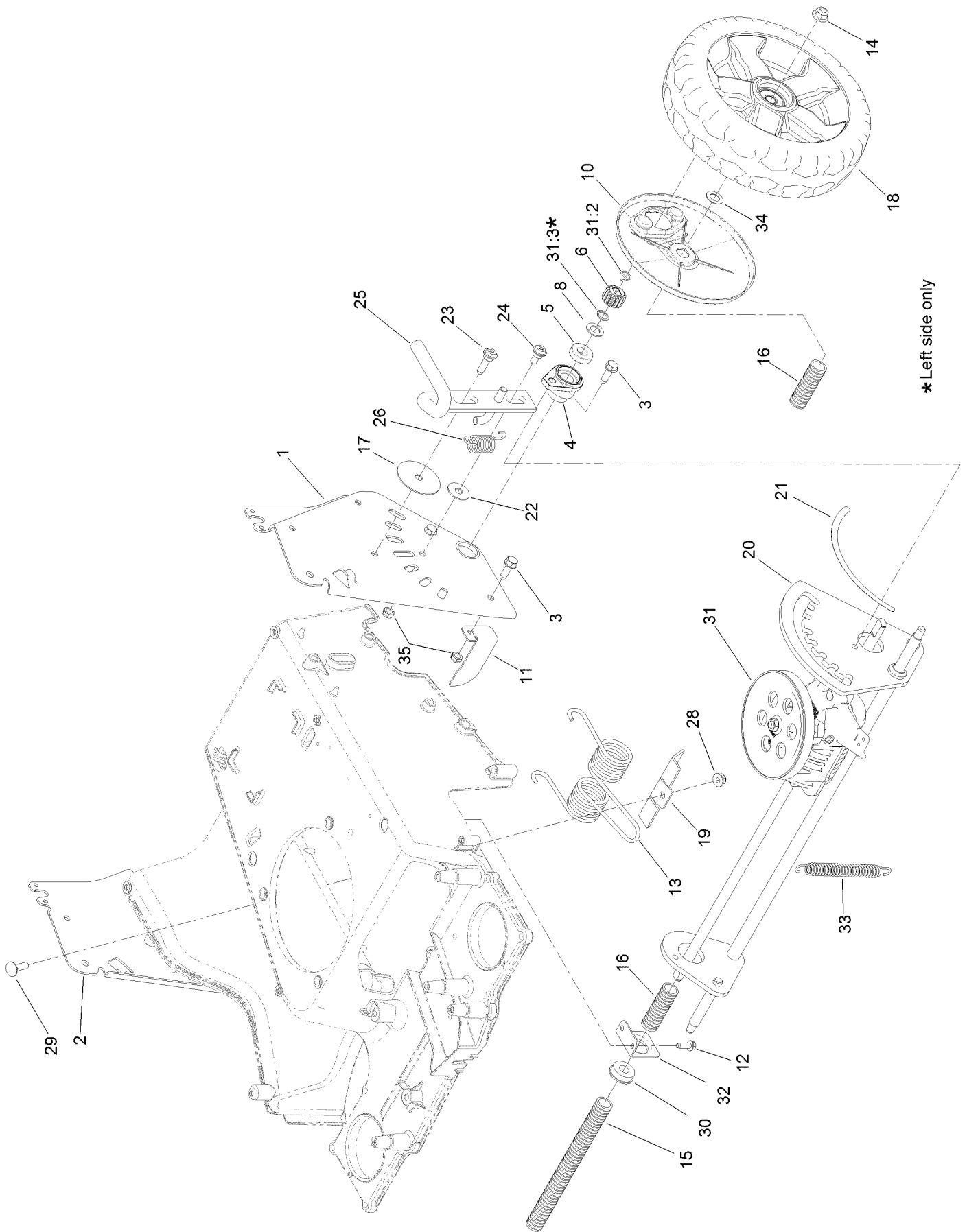



## Traction and Height-of-Cut Assembly (continued)

<i>Ref.</i>	<i>Part Number</i>	<i>Qty.</i>	<i>Description</i>	<i>Ref.</i>	<i>Part Number</i>	<i>Qty.</i>	<i>Description</i>
1	121-2394-03	1	LH HOC Plate ASM	20	131-4516	1	Axle-Rear
2	121-2395-03	1	RH HOC Plate ASM	21	116-7127	1	Decal-HOC, Rear
3	701243	7	Screw-HWHTF	22	52-2860	1	Washer
4	120-5210	2	Retainer-Bearing	23	119-2267	1	Screw-Shoulder, BHTF
5	109-8020	2	Bearing-Ball	24	120-9471	1	Bolt-Shoulder
6	110-9417	2	Gear-Pinion, 15T	25	120-7090	1	Lock-Height, Adjust
8	110-7191	2	Washer-Thrust	26	120-9452	1	Spring-Extension
10	125-2480	2	Cover-Gear	28	104-8300	1	Nut-Flange, NI
11	121-5821	1	Bracket-Stop	29	3230-2	1	Bolt-CARR
12	49-2040	2	Screw-HWHTF	30	104-8699	1	Bearing-Ball
13	121-2368	1	Spring-Torsion	31	131-9667	1	Transmission Kit
14	104-8301	2	Nut-Flange, NI	31:2	130-2369	2	Pin-Snap
15	121-5799	1	Conduit-Convoluted	31:3	32151-61	1	Ring-Retaining
16	121-5800	2	Conduit-Convoluted	32	120-7008	1	Mount-Bearing
17	125-2540	1	Washer-Plain	33	120-7027	1	Spring-Extension
18	131-4599	2	Wheel ASM (W/Gear)	34	36-4780	2	Washer-Plain
19	121-2397	1	Bracket	35	3296-47	2	Nut-Lock, NI

# Handle Assembly

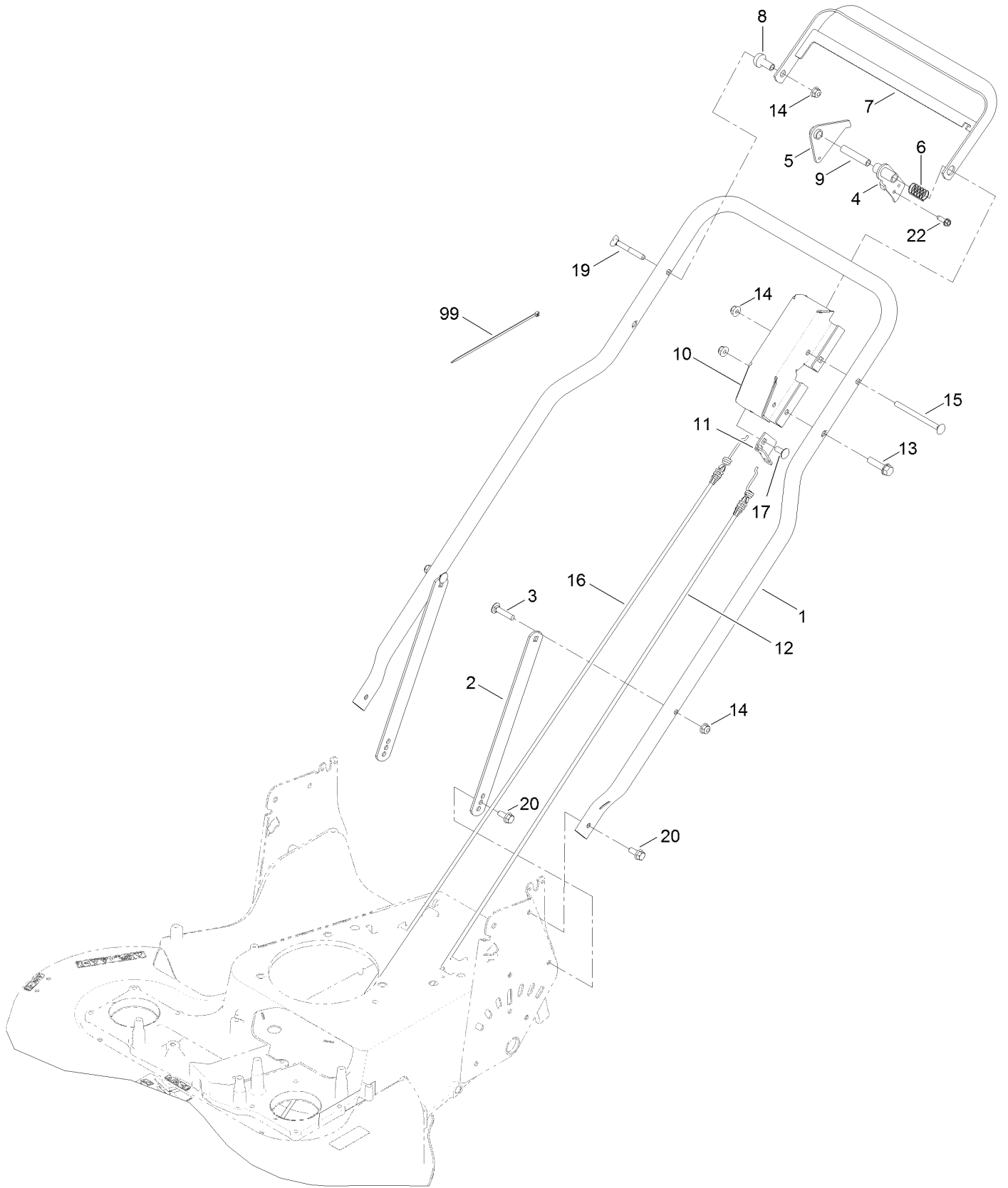

## Handle Assembly (continued)

<i>Ref.</i>	<i>Part Number</i>	<i>Qty.</i>	<i>Description</i>	<i>Ref.</i>	<i>Part Number</i>	<i>Qty.</i>	<i>Description</i>
1	121-5827-03	1	Handle	12	127-0741	1	Cable-Brake
2	116-8208-03	2	Support-Handle	13	32144-102	1	Screw-HWH
3	3230-4	2	Screw-CARR	14	104-8300	5	Nut-Flange, NI
4	121-5831	1	BBC Lever ASM	15	106-9758	1	Screw-CARR
5	121-9136	1	Lever-Traction	16	127-6868	1	Cable-Traction
6	85-6750	1	Spring-Control	17	3230-23	1	Screw-CARR
7	121-5829-03	1	Bar-Control	19	17-9427	1	Screw
8	49-1631	1	Spacer-Support	20	116-7230	4	Screw-HHF
9	84-9030	1	Spacer-Bracket, Control	22	49-2040	1	Screw-HWHTF
10	121-5789-03	1	Bracket-Control	99	614249	3	Tie-Cable
11	121-9166	1	Bracket				

# Attachments and Accessories

## For 22200 30in TurfMaster Walk-Behind Lawn Mower

<b>Product Name</b>	<b>Model/Part</b>
Atomic Blade 15.4in.....	120-9500-03
Mulching Kit.....	125-5064
Idler Pulley Kit.....	126-7890

**Notes:**

**Notes:**

**Notes:**



**Count on it.**