



Count on it.

Parts Catalog

MB-1600 Mud Buggy

Model No. 68038—Serial No. 313000001 and Up

Model No. 68038G—Serial No. 313000001 and Up



Ordering Replacement Parts

To order replacement parts, please supply the part number, the quantity, and the description of each part desired.

Understanding Reference Numbers

Each identified part in an illustration has a reference number. The reference number for a part also appears in the parts list, along with other information about the part.

This catalog uses two special reference number formats, one to indicate parts in a service assembly and another to indicate the quantity of a given part in an illustration.

Service Assembly Reference Numbers

Parts in service assemblies have reference numbers in the form a:b. The a represents the reference number of the entire service assembly and the b represents a sequential number unique to each part within the service assembly.

For example, a wheel assembly might be identified by reference number 6, the tire by 6:1, the valve by 6:2, and the wheel by 6:3. When you order the assembly identified by reference number 6, you receive all parts identified by reference numbers 6:1, 6:2, and 6:3. However, you may also order any part individually. Reference numbers of this type appear in illustration and in parts lists.

Reference Numbers Indicating Quantity

In an illustration, if a reference number indicates more than one part, the reference number has the form nX y. The n represents the quantity of the part, the X is the multiplication symbol, and the y represents the reference number.

For example, in an illustration, the reference number 2X 37 means that two of the parts identified by reference number 37 are indicated.

List of Abbreviations

AR: as required

ASM: assembly

BBC: blade brake control

BHTF: button head thread forming

CARR: carriage

CCW: counter clockwise

CW: clockwise

DEG: degrees

DPA: Dual Point Adjustment

ECM: electronic control module

EXT: external

FH: flat head

GA: gauge

HD: heavy-duty

HF: hex flange

HH: hex head

HHF: hex head flange

HHFTF: hex head flange thread forming

HJ: hex jam

HLH: hex lag head

HOC: height-of-cut

HP: high pressure

HSBH: hex socket button head

HSFH: hex socket flat head

HSH: hex socket head

HWH: hex washer head

HWHTF: hex washer head thread forming

HYD: hydraulic

LH: left hand

LP: low pressure

LPG: Liquefied Petroleum Gas

NI: nylon insert

NPTF: national pipe thread fine

PFH: phillips flat head

PPH: phillips pan head

PPHTF: phillips pan head thread forming

PRH: phillips round head

PTH: phillips truss head

PTO: power-take-off

RH: right hand

ROPS: roll-over protection system

RRB: rear roller brush

SFH: slotted fillister head

SHH: slotted hex head

SHWH: slotted hex washer head

SPH: slotted pan head

SQH: square head

SRH: slotted round head

STD: standard

TAP: self tapping

TTH: torx truss head

Contents

Engine and Fuel Tank Assembly	4
Pump Adaptor and Mounting Assembly	5
Piston Pump and Bracket Assembly	6
Hydraulic Piston Pump Assembly No. ST50957	7
Gear Motor and Cylinder Assembly	8
Hydraulic Motor Assembly No. ST50926	9
Steering Handle and Axle Assembly	10
Main Frame Assembly	11
Brake and Hopper Assembly	12
Wheel and Brake Assembly	14
Front Wheel and Hub Assembly	15
Hub Assembly No. 125-8171	16
Hydraulic Tank and Dump Pedal Assembly	17
Hydraulic Hard Line Routing Assembly	19
Hydraulic Hose and Fitting Assembly	20

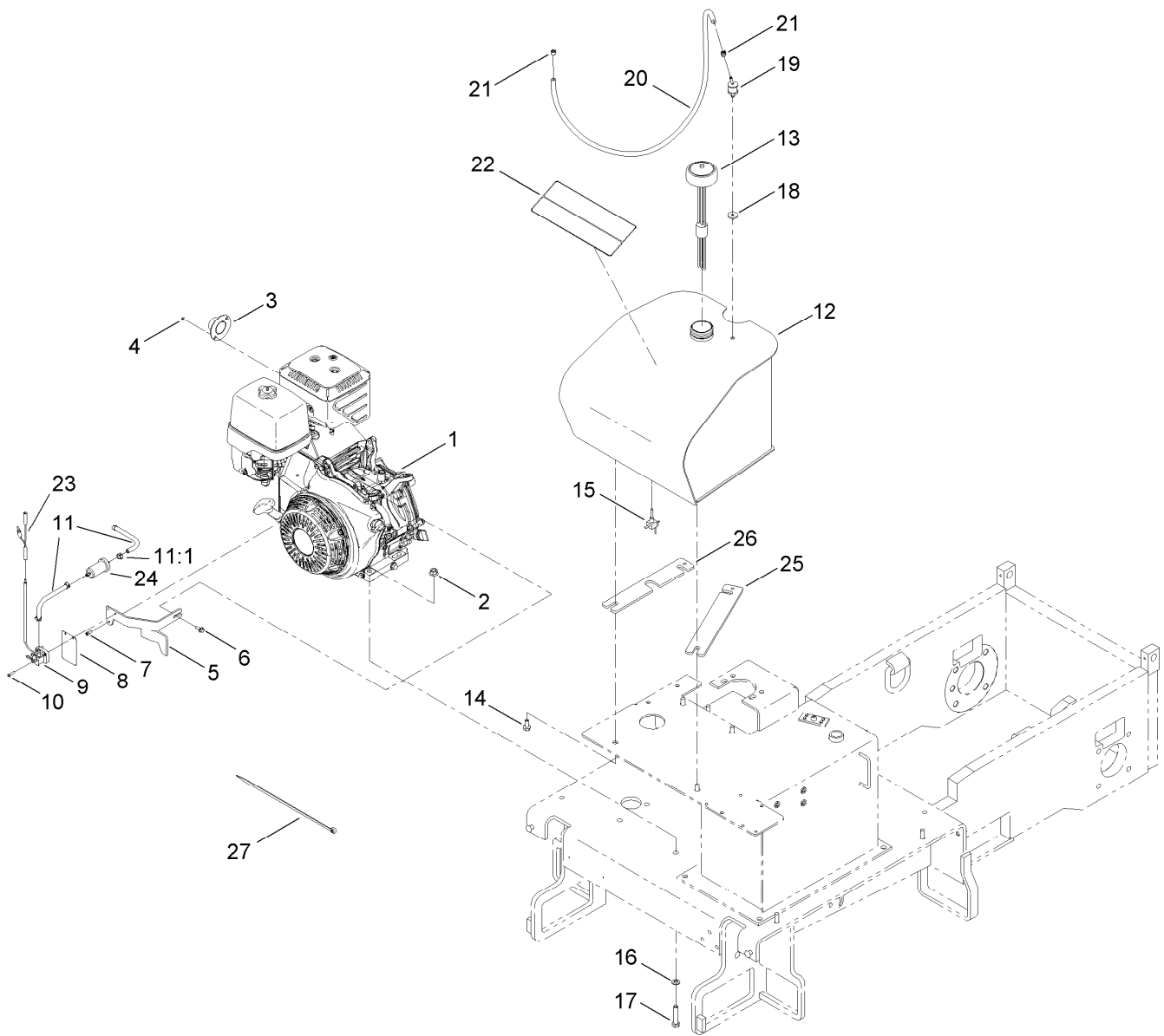

Engine and Fuel Tank Assembly

Ref.	Part Number	Qty.	Description	Ref.	Part Number	Qty.	Description
1	125-4819	1	Engine-Honda, Gx390 ●	14	33104-025	4	Screw-HHF
2	33005-00	4	Nut-HF	15	ST39056	1	Valve-Strainer
3	ST50553-03	1	Deflector-Exhaust	16	33095-00	4	Washer-Flat
4	120-1884	2	Screw-PPHTF	17	33115-050	4	Screw-HH
5	ST45910-03	1	Bracket-Switch, Stop Fuel	18	ST36123	1	Grommet-Tank, Top
6	33103-016	1	Screw-HHF	19	ST36122	1	Valve-Slosh
7	115-8733	1	Screw -HSH	20	108-9698	1	Hose-Fuel
8	125-4966	1	Hang Tag-Run, Stop	21	2412-80	2	Clamp-Hose
9	ST58582	1	Fuel Shut Off Valve ASM	22	125-4958	1	Decal-Operation
10	119-7444	2	Screw-HSBH	23	127-2880	1	Harness-Wire, Shut Down T
11	127-2810	2	Fuel Hose Kit	24	ST36144	1	Filter-Fuel
11:1	2412-98	2	Clamp-Hose	25	127-5595-03	1	Plate-Tank Stand Off
12	127-4084-03	1	Tank-Fuel	26	127-5598-03	1	Plate-Tank Stand Off
13	ST36140	1	Gauge-Fuel	27	1-303335	1	Tie-Plastic

● Obtain parts from www.honda-engines.com

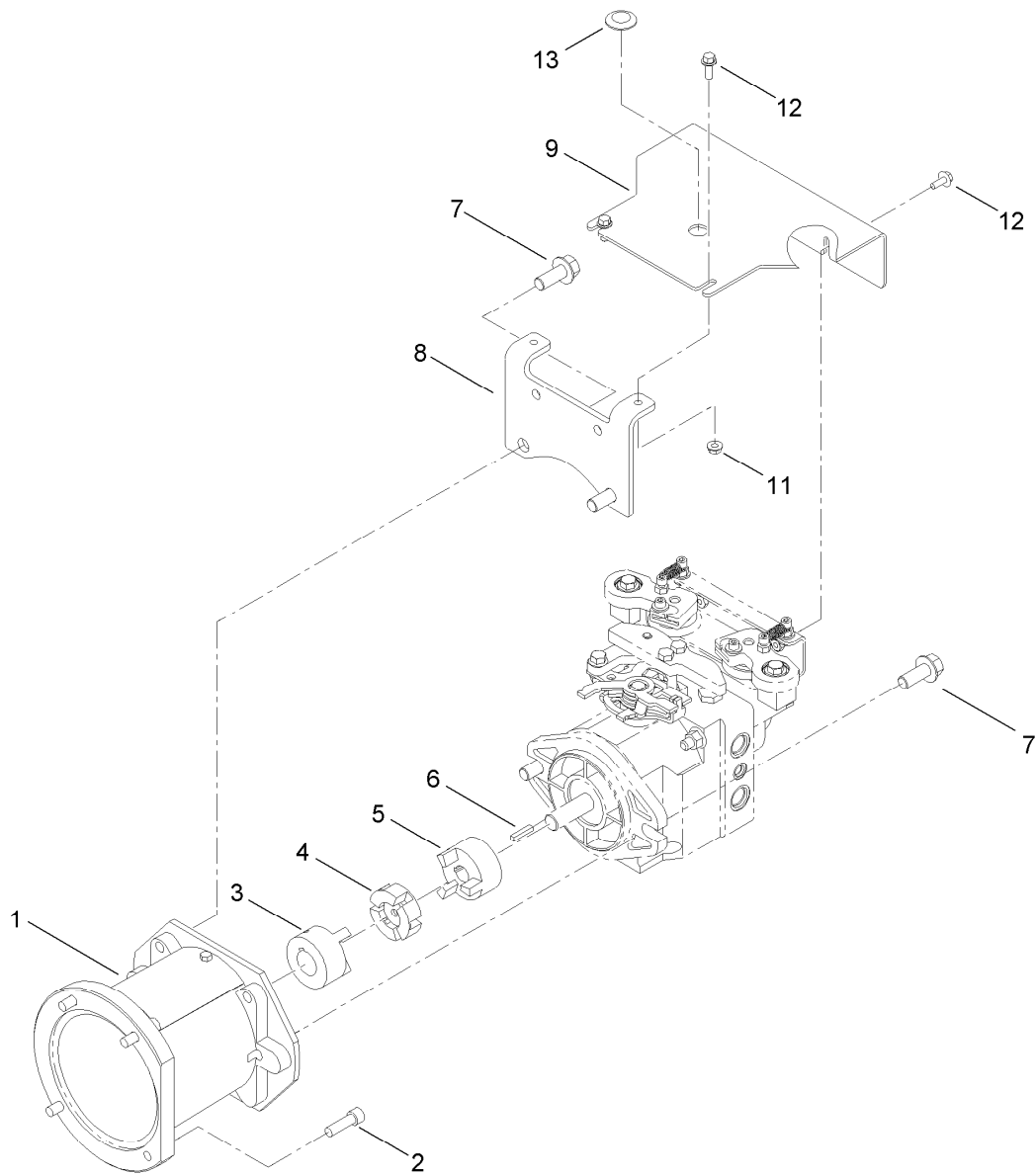

Pump Adaptor and Mounting Assembly

<i>Ref.</i>	<i>Part Number</i>	<i>Qty.</i>	<i>Description</i>
1	ST32432	1	Adaptor-Motor, Pump
2	3274-1	4	Screw-HSH
3	ST37547	1	Coupling-Engine
4	ST37548	1	Insert-Coupling
5	ST45154	1	Coupling-Pump
6	ST45093	1	Key-Square
7	3234-32	4	Screw-HHF
8	ST50952-03	1	Plate-Mounting, Cable
9	ST50953-03	1	Cover-Control, Pump
11	32128-14	2	Nut-HF
12	99-6810	4	Screw-HHF
13	ST57909	1	Plug-Button

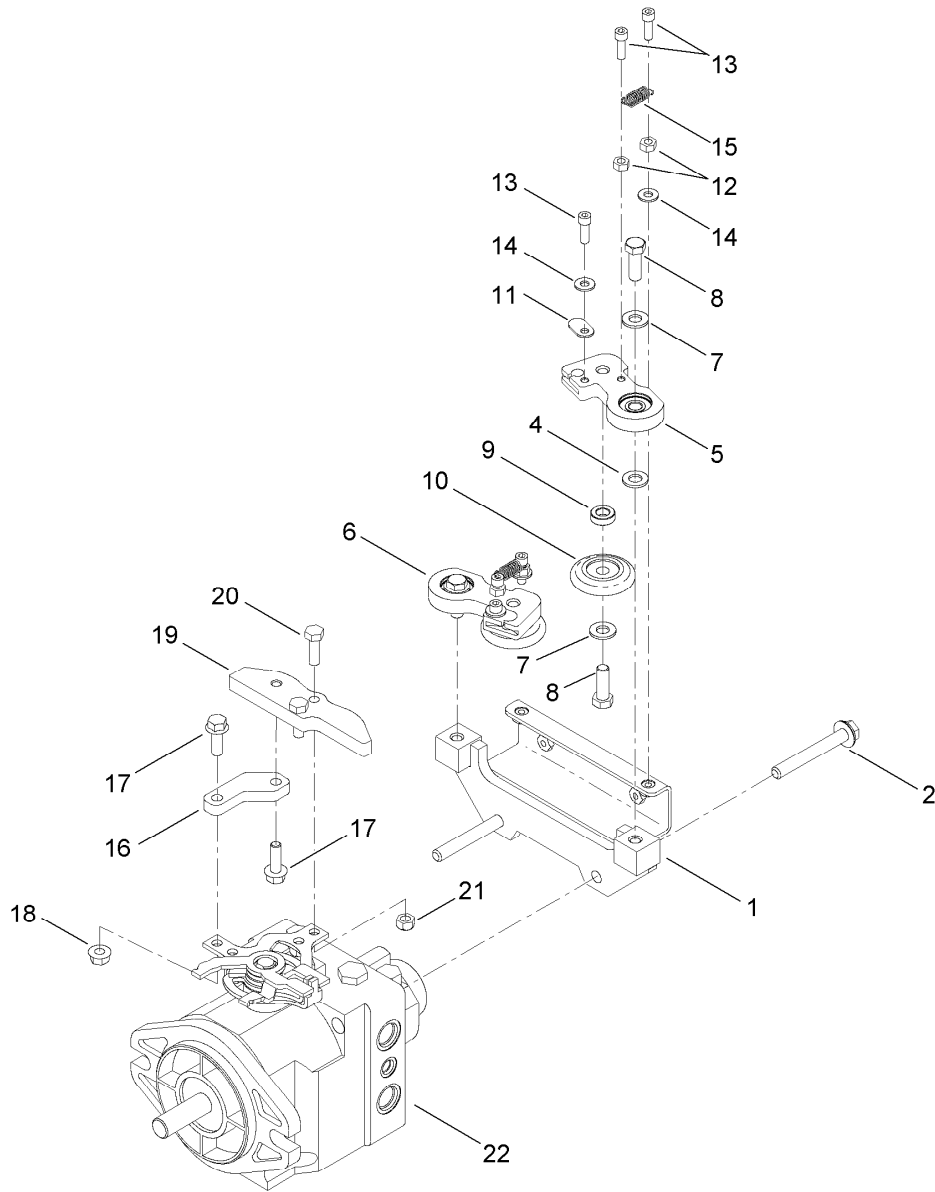

Piston Pump and Bracket Assembly

<i>Ref.</i>	<i>Part Number</i>	<i>Qty.</i>	<i>Description</i>	<i>Ref.</i>	<i>Part Number</i>	<i>Qty.</i>	<i>Description</i>
1	125-6369	1	Bracket-Control, Pump	13	3274-64	6	Screw-HSH
2	33105-070	2	Screw-HHF	14	3256-22	4	Washer-Flat
4	33095-00	2	Washer-Flat	15	ST50991	2	Spring-Extension, Control Pump
5	125-8557	1	Control-Pivot Right	16	ST50951	1	Plate-Arm, Control
6	125-8555	1	Control-Pivot Left	17	33104-025	2	Screw-HHF
7	3256-24	4	Washer-Flat	18	33004-00	1	Nut-HF
8	323-18	4	Screw-HH	19	ST50954	1	Plate-Pump, Control
9	ST50948	2	Spacer-Pivot	20	33114-025	2	Screw-HH
10	ST43873	2	Wheel-Cutting, Table	21	33024-00	2	Nut-Lock, NI
11	ST50955	2	Cover-End, Cable	22	ST50957	1	HYD Piston Pump ASM
12	3217-5	4	Nut-Hex				

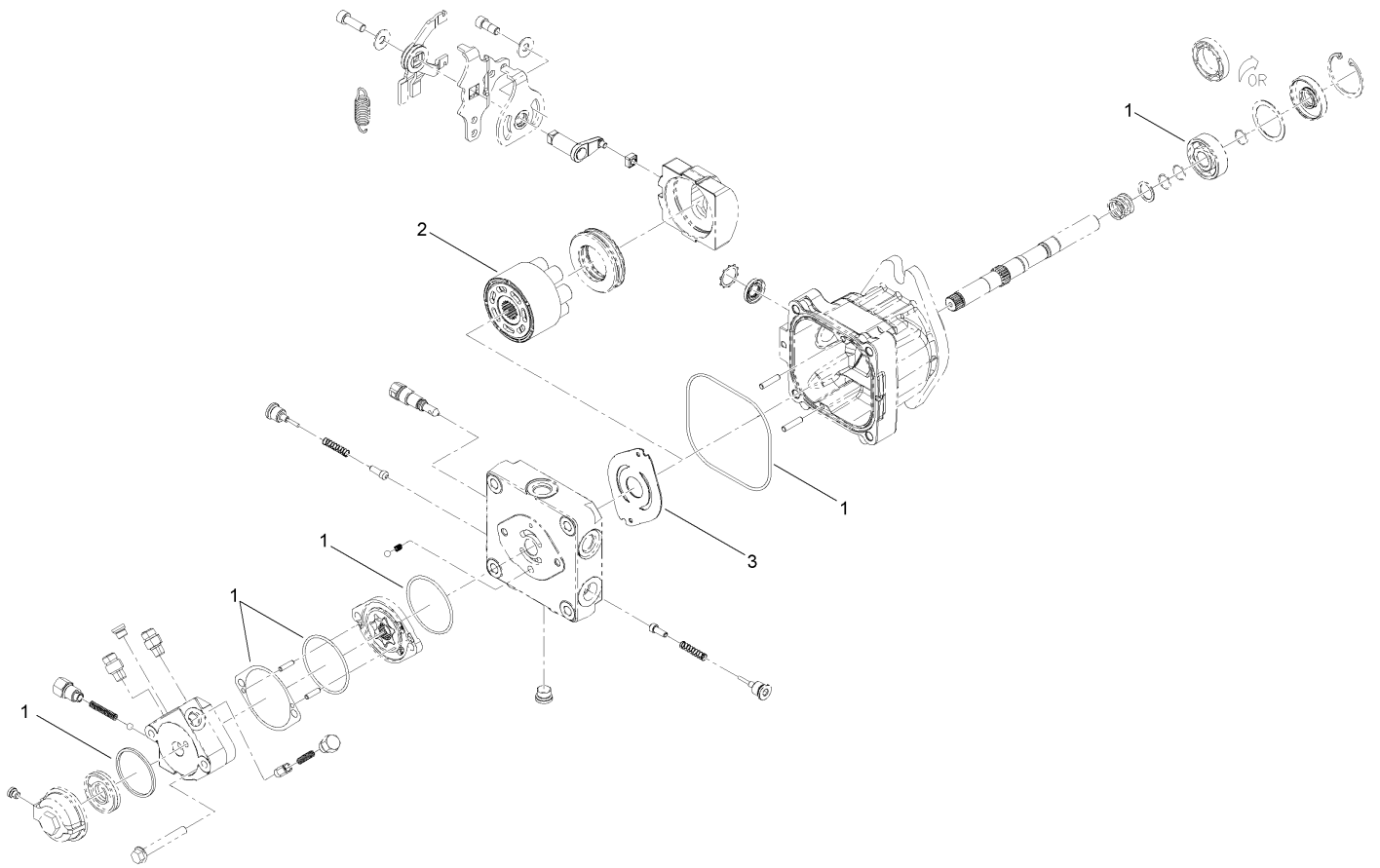

Hydraulic Piston Pump Assembly No. ST50957

<i>Ref.</i>	<i>Part Number</i>	<i>Qty.</i>	<i>Description</i>
1	100-6110	1	Overhaul Seal Kit
2	127-3867	1	Cylinder Block Kit
3	100-6112	1	Plate-Valve

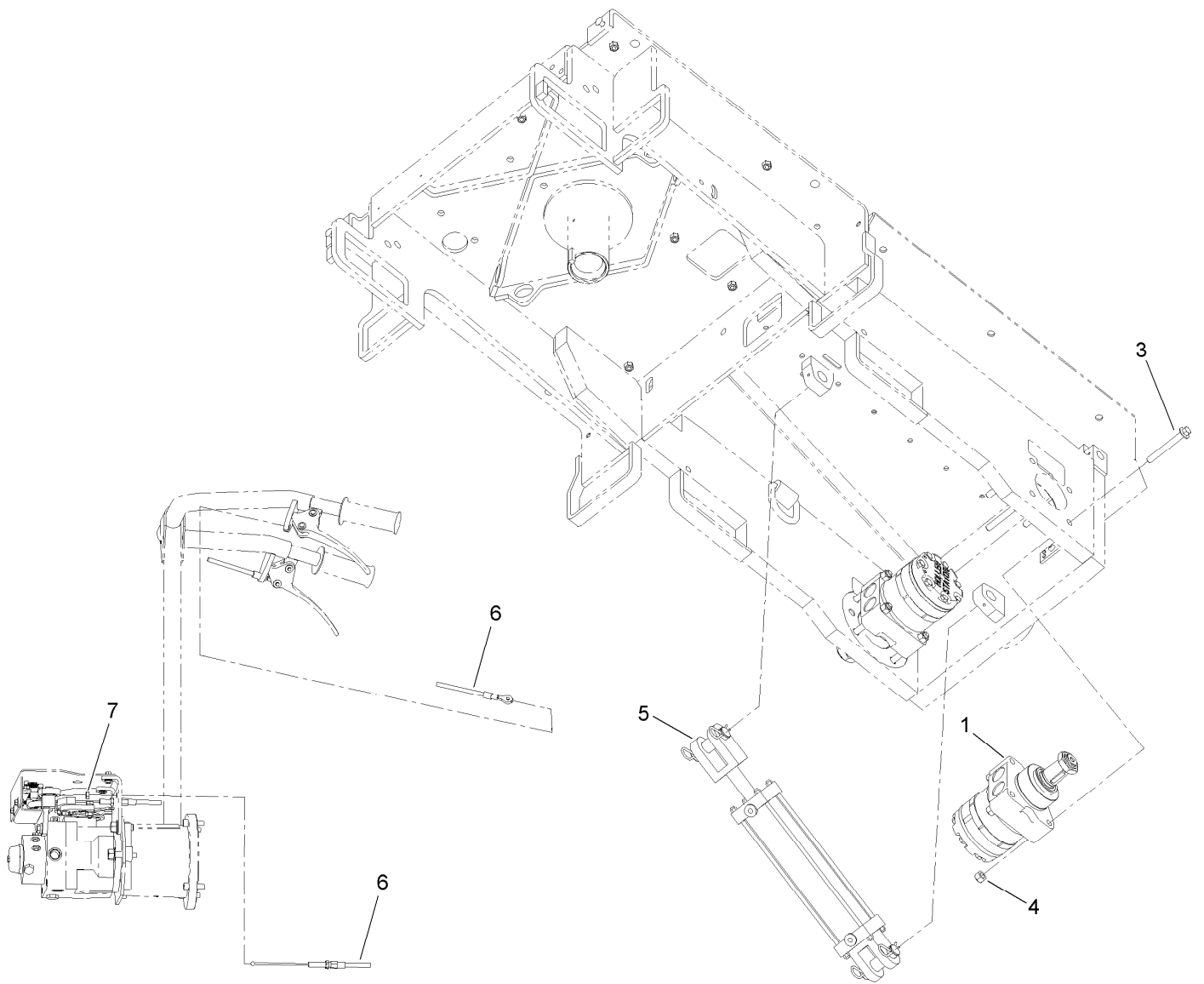

Gear Motor and Cylinder Assembly

<i>Ref.</i>	<i>Part Number</i>	<i>Qty.</i>	<i>Description</i>
1	ST50926	2	HYD Gear Motor ASM
3	33106-100	8	Screw-HHF
4	33026-00	8	Nut-Lock
5	ST50501	1	HYD Cylinder ASM
6	ST50959	2	Cable-Control
7	3220-3	2	Nut-HJ

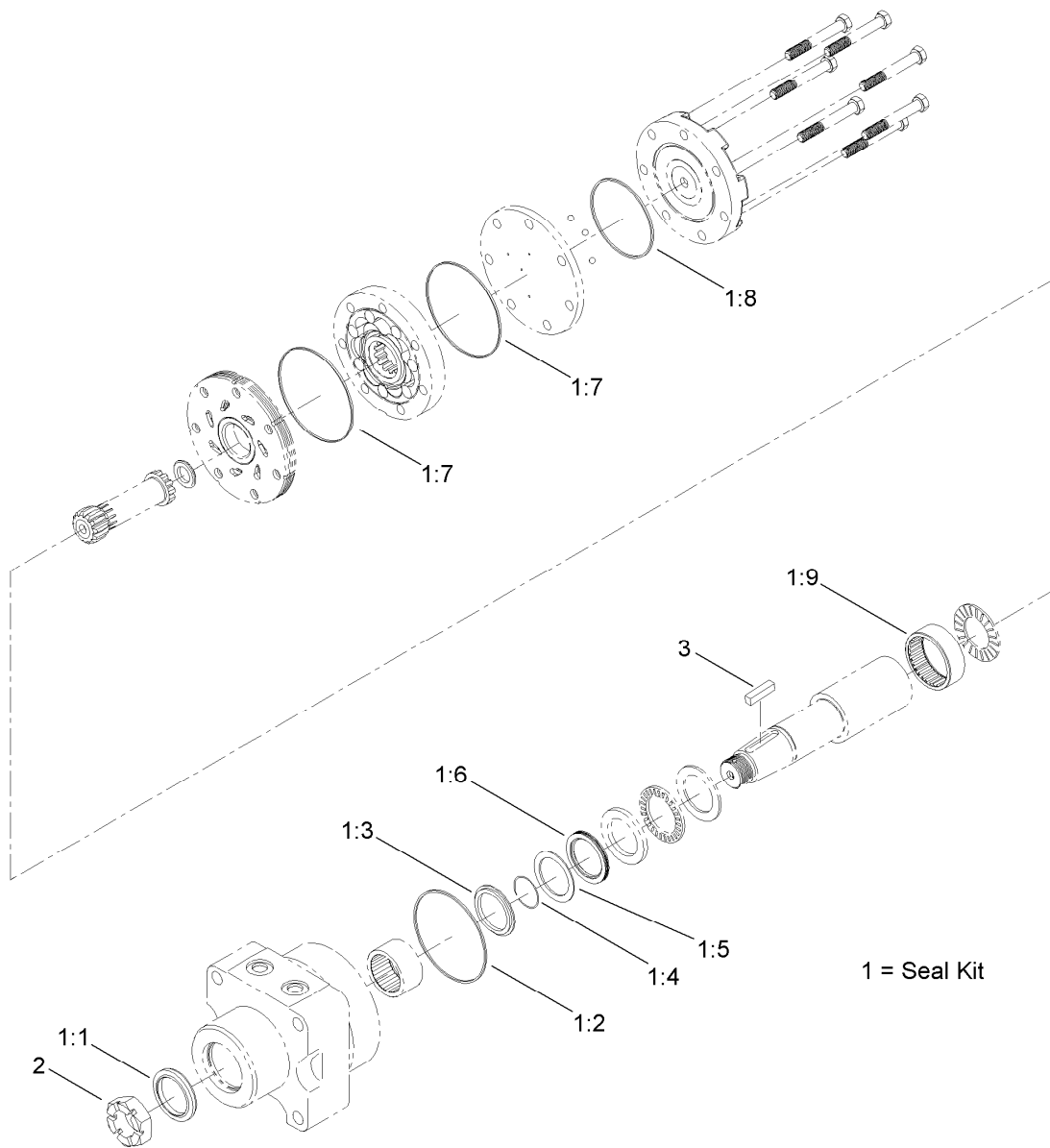

Hydraulic Motor Assembly No. ST50926

Ref.	Part Number	Qty.	Description
1	127-5568	1	Seal Kit
1:1		1	Seal-Dust ●
1:2		1	Seal-Housing ●
1:3		1	Ring-Back Up, Metal ●
1:4		1	Shim-Back Up ●
1:5		1	Seal-Back Up ●
1:6		1	Seal-Shaft ●
1:7		2	Seal-Body ●
1:8		1	Seal-Endcover ●
1:9		1	Bearing-Housing, Rear ●
2	127-5569	1	Nut-Shaft
3	127-5570	1	Key-Shaft

● Not serviced separately

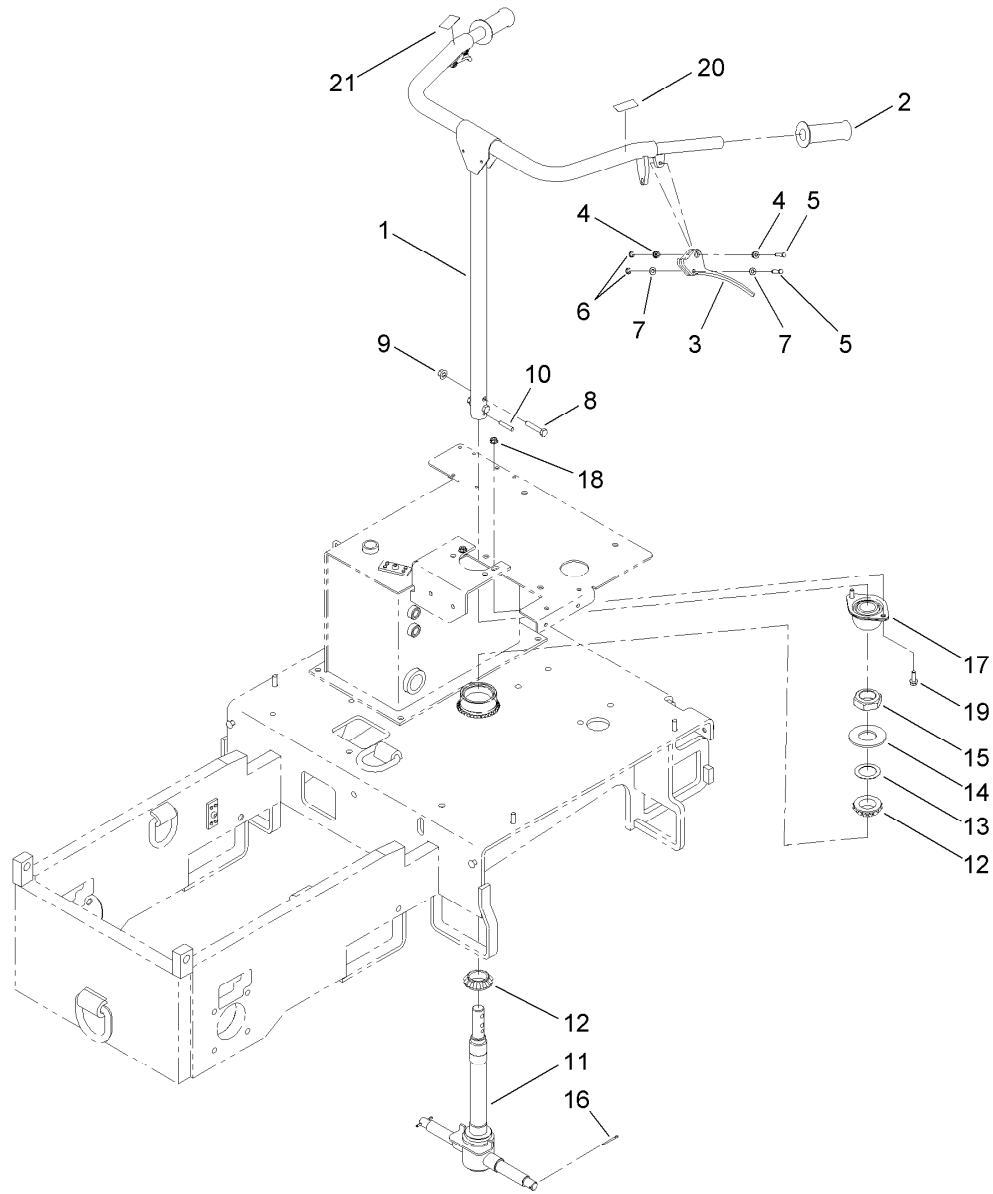

Steering Handle and Axle Assembly

<i>Ref.</i>	<i>Part Number</i>	<i>Qty.</i>	<i>Description</i>	<i>Ref.</i>	<i>Part Number</i>	<i>Qty.</i>	<i>Description</i>
1	ST50941-03	1	Handle-Steering	12	ST32161	2	Bearing-Roller
2	ST47125	2	Grip-Handle	13	ST81109	1	Washer-Thrust
3	ST50937	2	Handle-Control,	14	ST36934	1	Plate-Cover, Bearing
4	ST50938	4	Bushing-Lever, Control	15	ST81108	1	Nut
5	ST81220	4	Pin-Clevis	16	3272-13	2	Pin-Cotter
6	32151-86	4	E-Ring	17	ST45930	1	Spherical Bearing ASM
7	3256-22	4	Washer-Flat	18	32128-26	2	Nut-Flange
8	33115-050	2	Screw-HH	19	3234-29	2	Screw-HHF
9	33005-00	2	Nut-HF	20	125-4961	1	Decal-Reverse
10	ST80309	1	Pin	21	125-4960	1	Decal-Forward
11	ST37358-03	1	Axle-Steering				

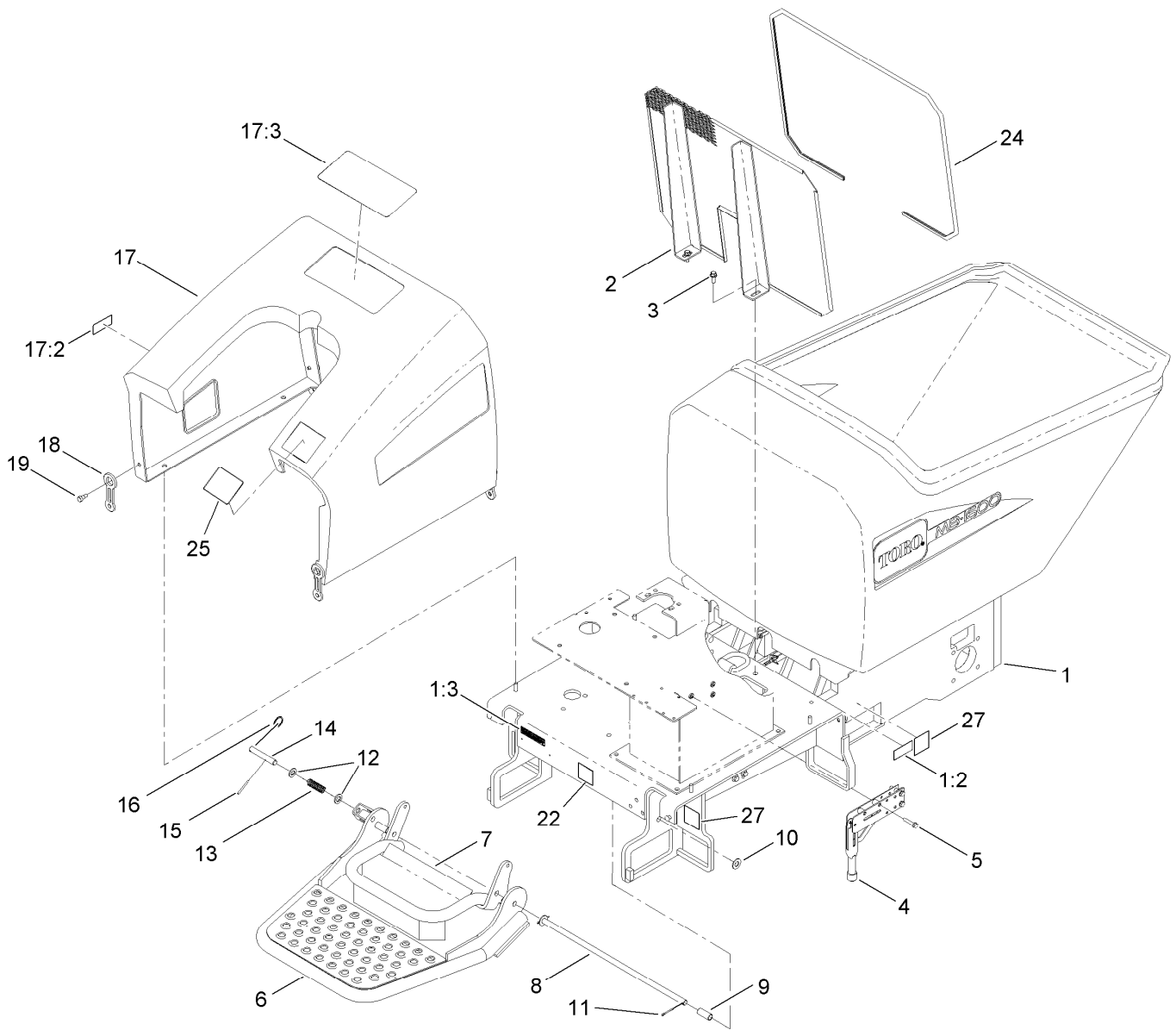

Main Frame Assembly

<i>Ref.</i>	<i>Part Number</i>	<i>Qty.</i>	<i>Description</i>	<i>Ref.</i>	<i>Part Number</i>	<i>Qty.</i>	<i>Description</i>
1	127-2834	1	Main Frame ASM	13	ST45055	1	Spring-Compression
1:2	125-4959	2	Decal-Warning, Crushing	14	ST45056	1	Pin-Lockout, Step
1:3	117-2718	1	Decal-Arrester, Spark	15	ST81122	1	Pin
2	125-8233-03	1	Guard-Splash	16	ST81124	1	Ring-Split
3	3234-42	2	Screw-HHF	17	127-2833	1	Engine Cowl ASM
4	ST38095	1	Lever	17:2	125-4963	1	Decal-Surface, Hot
5	33104-045	3	Screw-HHF	17:3	125-4957	1	Decal-Warning
6	125-8696-03	1	Step-Platform	18	ST47182	4	Latch-Rubber
7	125-8235-03	1	Pedal-Brake	19	ST81130	4	Screw-HSBH
8	ST45113	1	Shaft-Pivot, Step	22	125-8190	1	Decal-Brake Pedal
9	ST45249	2	Spacer-Brake	24	127-5590	1	Trim-Splash Guard
10	3256-27	2	Washer-Flat	25	125-4955	1	Decal-Dump
11	3272-13	6	Pin-Cotter	27	125-4967	4	Decal-Lift Here
12	33098-00	2	Washer-Flat				

Brake and Hopper Assembly (continued)

<i>Ref.</i>	<i>Part Number</i>	<i>Qty.</i>	<i>Description</i>	<i>Ref.</i>	<i>Part Number</i>	<i>Qty.</i>	<i>Description</i>
1	ST45073-03	1	Bin-Base	18	3220-2	2	Nut-Jam
2	ST45096	1	Shaft-Pivot	19	32120-47	1	Ring-Retaining, External
3	3256-28	2	Washer-Flat	20	ST45199	1	Cable-Brake, Buggy
4	3272-13	6	Pin-Cotter	21	ST50995	2	Rod-Brake, Front
5	302-5	7	Fitting-Grease	22	3219-1	4	Nut-Hex
6	ST47001	7	Cap-Plug	23	ST38561	4	Clevis
7	125-4806	1	Hopper-Mortar	24	ST45222	1	Rod-Brake
8	ST80740	6	Bolt-Elevator	25	3220-3	2	Nut-HJ
9	104-8301	6	Nut-Flange, NI	26	ST39255	2	End-Yoke
10	ST50925	1	Shaft-Pivot, Lever (Brake)	27	3256-23	2	Washer-Flat
11	3256-6	3	Washer-Flat	28	3253-4	2	Washer-Lock
12	ST50571-03	1	Lever-Brake	29	103-5752	2	Stud-Ball
13	3256-24	2	Washer-Flat	30	ST36571	1	Spring-Gas
14	ST81110	1	Pin-Clevis	31	ST57435	1	Plate-Pivot, Spring (Gas)
15	3272-10	1	Pin-Cotter	32	33105-025	2	Screw-HHF
16	ST45129	1	Clevis-Half	35	125-6694	3	Decal-Tie Down
17	ST45128	1	Clevis-Half (Notched)				

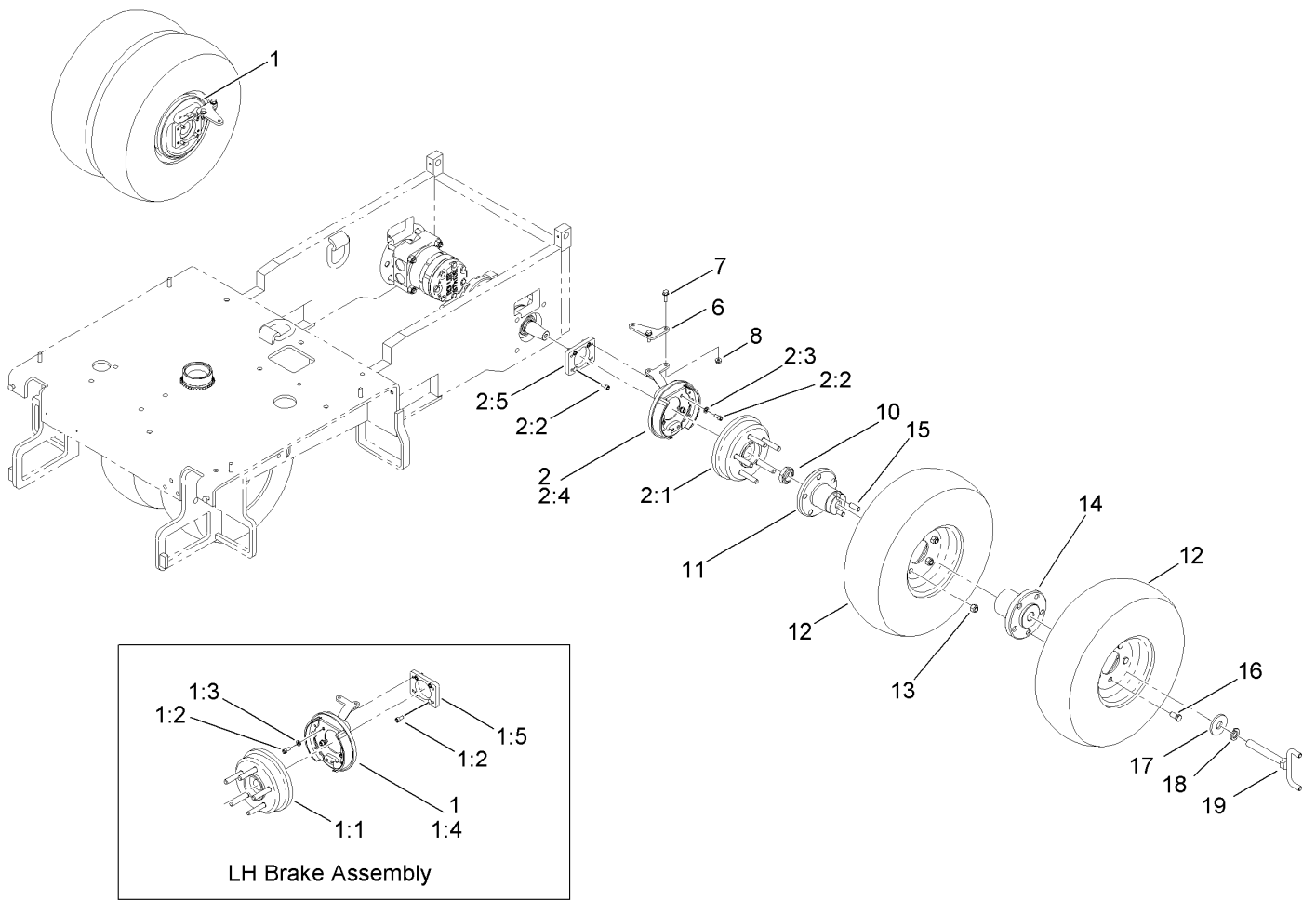

Wheel and Brake Assembly

Ref.	Part Number	Qty.	Description	Ref.	Part Number	Qty.	Description
1	ST50927	1	LH Brake ASM	7	3234-29	4	Screw-HHF
1:1	127-5562	1	5 Lug Hub ASM	8	32128-26	4	Nut-Flange
1:2	127-5563	8	Bolt	10	127-5569	2	Nut-Shaft
1:3	127-5564	4	Washer-Lock	11	ST50994	2	Spacer-Wheel, 5 Bolt
1:4	127-5565	1	Brake-LH	12	ST45197	4	Wheel ASM (With Foam)
1:5	127-5567	1	Block-Brake Mount	13	ST80045	10	Nut-Lug
2	ST50928	1	RH Brake ASM	14	ST45080	2	Spacer-Wheel
2:1	127-5562	1	5 Lug Hub ASM	15	ST80423	4	Pin-Rod, Connecting
2:2	127-5563	8	Bolt	16	ST81114	10	Bolt-Lug
2:3	127-5564	4	Washer-Lock	17	ST81014	2	Washer-Flat
2:4	127-5566	1	Brake-RH	18	100-7607	2	Washer-Lock
2:5	127-5567	1	Block-Brake Mount	19	ST45106	2	Pin-Quick Release
6	ST50923	2	Plate-Linkage, Brake				

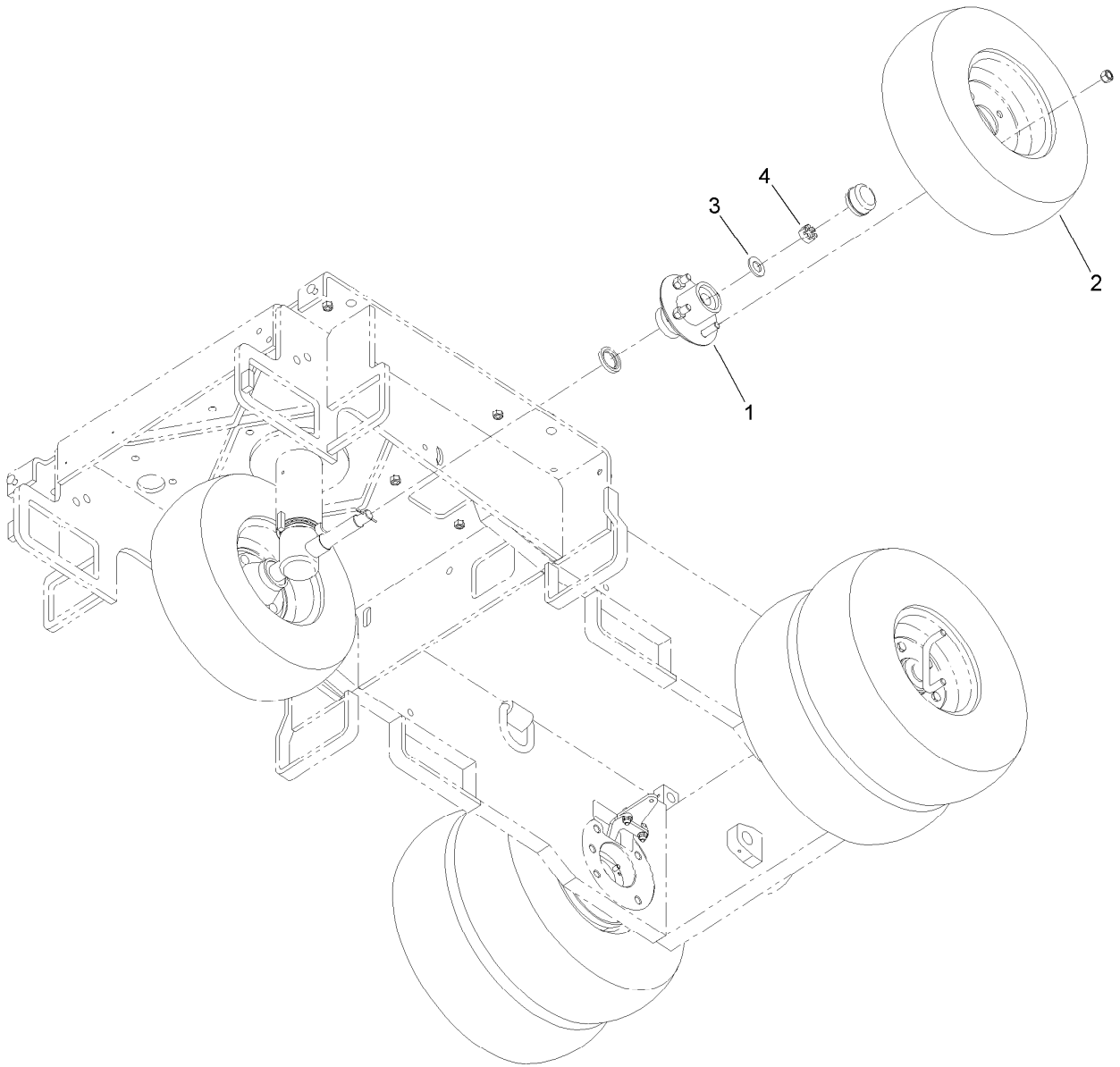

Front Wheel and Hub Assembly

<i>Ref.</i>	<i>Part Number</i>	<i>Qty.</i>	<i>Description</i>
1	125-8171	2	Hub ASM
2	ST45176	2	Wheel ASM (With Foam)
3	3256-28	2	Washer-Flat
4	ST80054	2	Nut

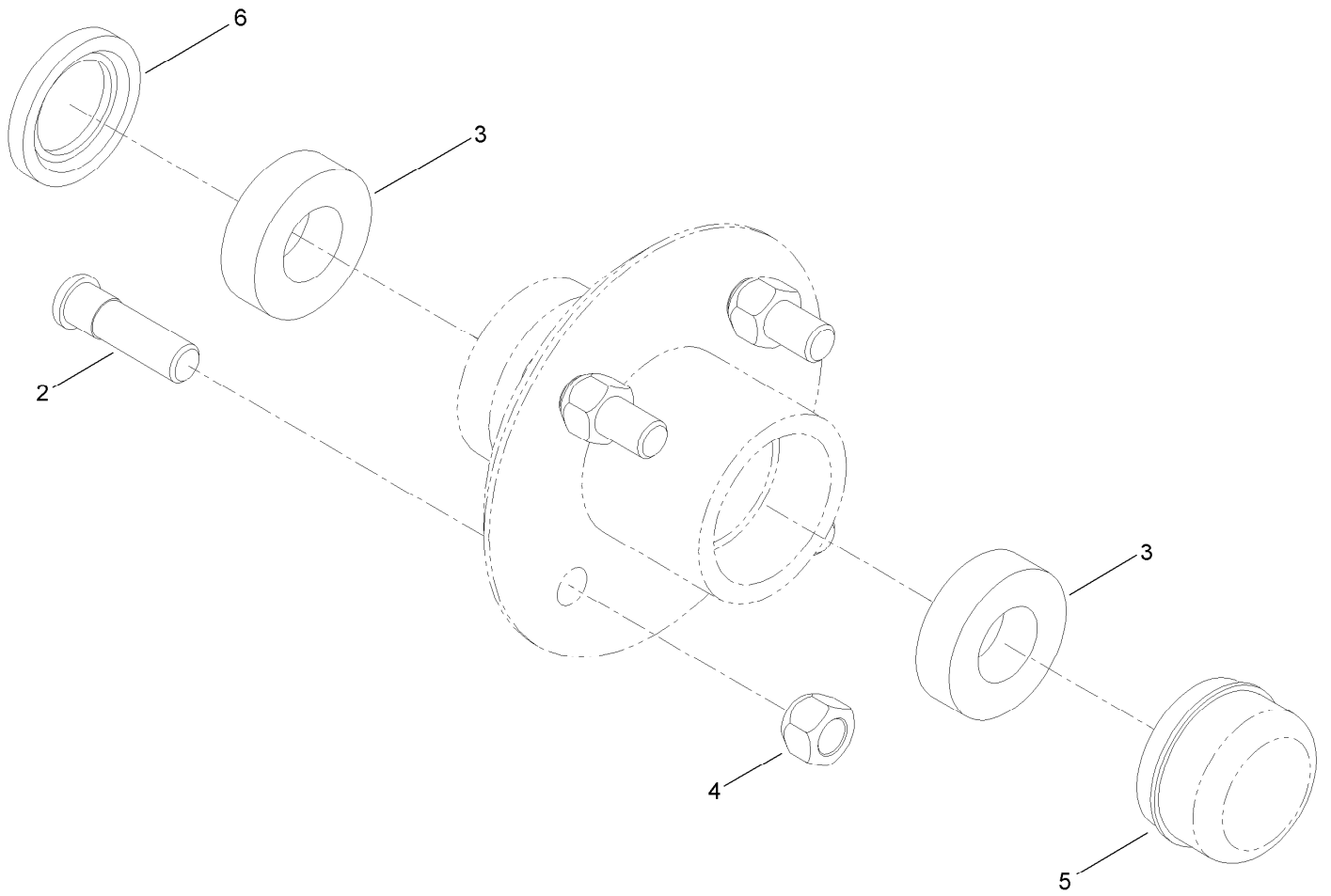

Hub Assembly No. 125-8171

<i>Ref.</i>	<i>Part Number</i>	<i>Qty.</i>	<i>Description</i>
2	ST39190	4	Stud-Wheel
3	ST32233	2	Bearing-Roller
4	ST80045	4	Nut-Lug
5	ST34573	1	Cap-Dust
6	ST32052	1	Seal-Hub, Wheel

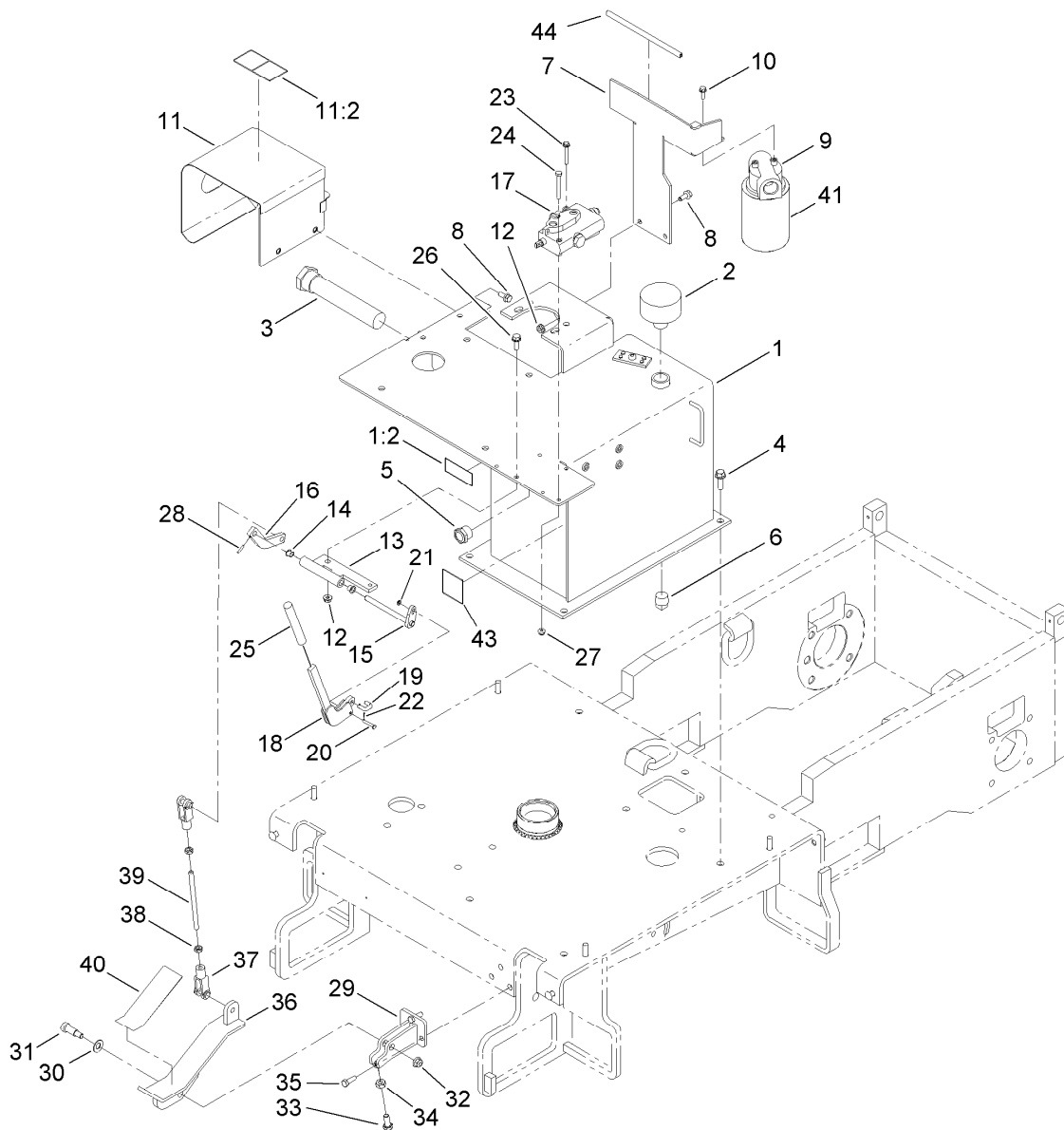

Hydraulic Tank and Dump Pedal Assembly

Ref.	Part Number	Qty.	Description	Ref.	Part Number	Qty.	Description
1	127-7506	1	HYD Tank ASM	20	ST36978	1	Pin-Clevis
1:2	125-4964	1	Decal-Caution, HYD Fluid	21	52-6430	1	Washer
2	ST38521	1	Breather-Filler	22	ST36981	2	Pin-Cotter
3	ST39088	1	Strainer	23	32105-18	1	Screw-HHF
4	3234-24	4	Screw-HHF	24	321-18	1	Screw-HH
5	ST38534	1	Glass Sight ASM	25	ST34687	1	Grip-Handle
6	ST46774	1	Plug	26	3234-29	1	Screw-HHF
7	125-8717-03	1	Bracket-Filter, Oil	27	104-7201	1	Nut-Flange, NI
8	3234-47	4	Screw-HHF	28	ST81076	1	Pin
9	ST45150	1	Filter-Return	29	ST45973-03	1	Mount-Pedal
10	117-8304	2	Screw-HHF	30	ST80639	1	Washer-Belleville
11	127-2832	1	Heat Sheild ASM	31	ST80957	1	Screw-HSBH
11:2	125-4963	1	Decal-Surface, Hot	32	104-8301	1	Nut-Flange, NI
12	32128-26	3	Nut-Flange	33	33115-025	1	Screw-HH
13	ST45960-03	1	Guide-Shaft	34	33015-00	1	Nut-Hex
14	ST32466	2	Bearing	35	322-5	3	Screw-HH
15	ST58337-03	1	Lever-Control, Foot Valve	36	ST45963-03	1	Pedal-Dump
16	ST45968-03	1	Actuator-Arm	37	ST39255	2	End-Yoke
17	ST57532	1	Directional HYD Valve ASM	38	3220-3	2	Nut-HJ
18	ST58334-03	1	Lever-Valve, Control	39	ST36744	1	Rod-Linkage
19	ST36982	1	Link-Handle, Valve	40	ST45959	1	Tread-Skid

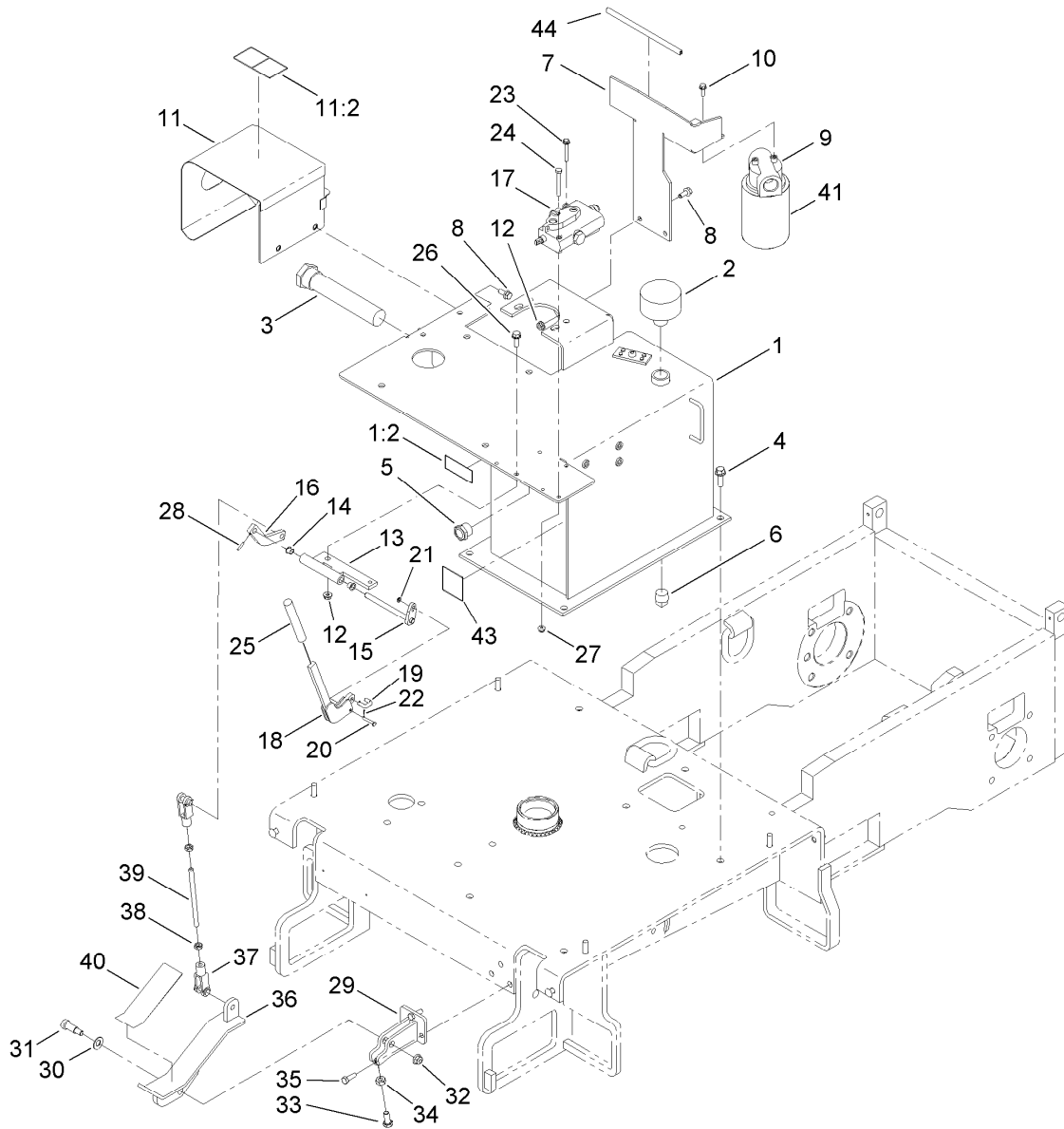

Hydraulic Tank and Dump Pedal Assembly (continued)

<i>Ref.</i>	<i>Part Number</i>	<i>Qty.</i>	<i>Description</i>
41	ST35445	1	Element-HYD Oil, 10 Micron

<i>Ref.</i>	<i>Part Number</i>	<i>Qty.</i>	<i>Description</i>
43	125-4962	1	Decal-P Brake
44	127-5591	1	Trim-Filter Bracket

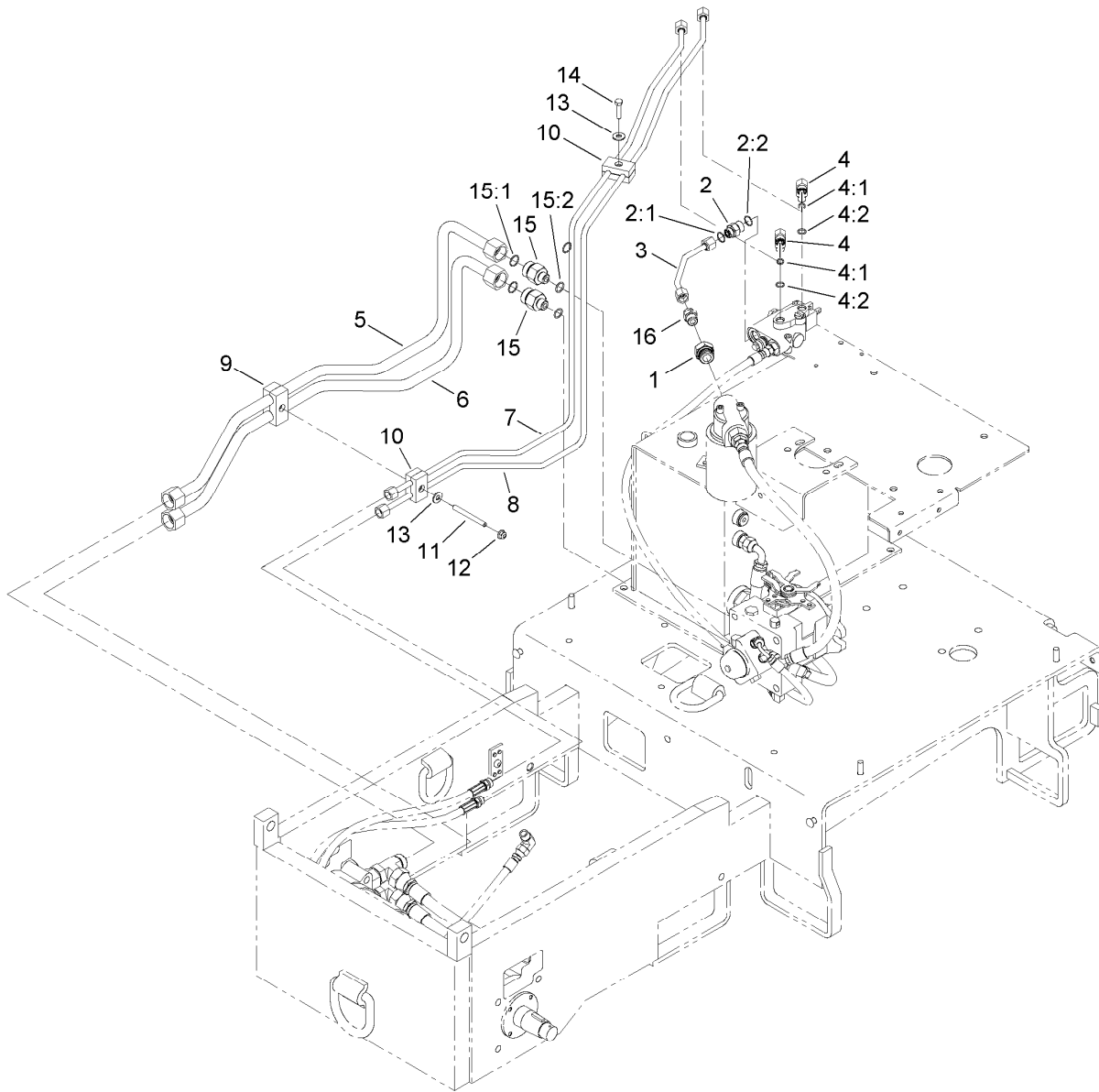

Hydraulic Hard Line Routing Assembly

<i>Ref.</i>	<i>Part Number</i>	<i>Qty.</i>	<i>Description</i>	<i>Ref.</i>	<i>Part Number</i>	<i>Qty.</i>	<i>Description</i>
1	ST50971	1	Fitting-HYD	8	125-8568	1	HYD Tube ASM
2	340-3	1	Adapter	9	ST50985	1	Clamp-Twin
2:1	237-22	1	O-Ring	10	ST37530	2	Clamp-Twin
2:2	237-79	1	O-Ring	11	ST50990	1	Rod-Clamp, Hose
3	125-8566	1	HYD Tube ASM	12	104-8300	1	Nut-Flange, NI
4	340-77	2	Fitting-HYD, 90 DEG	13	3256-3	2	Washer-Flat
4:1	237-22	1	O-Ring	14	322-6	1	Screw-HH
4:2	237-42	1	O-Ring	15	98-9921	2	Fitting-Thread, Straight
5	125-8564	1	HYD Tube ASM	15:1	237-145	1	O-Ring
6	125-8565	1	HYD Tube ASM	15:2	237-79	1	O-Ring
7	125-8567	1	HYD Tube ASM	16	ST46679	1	Fitting-HYD

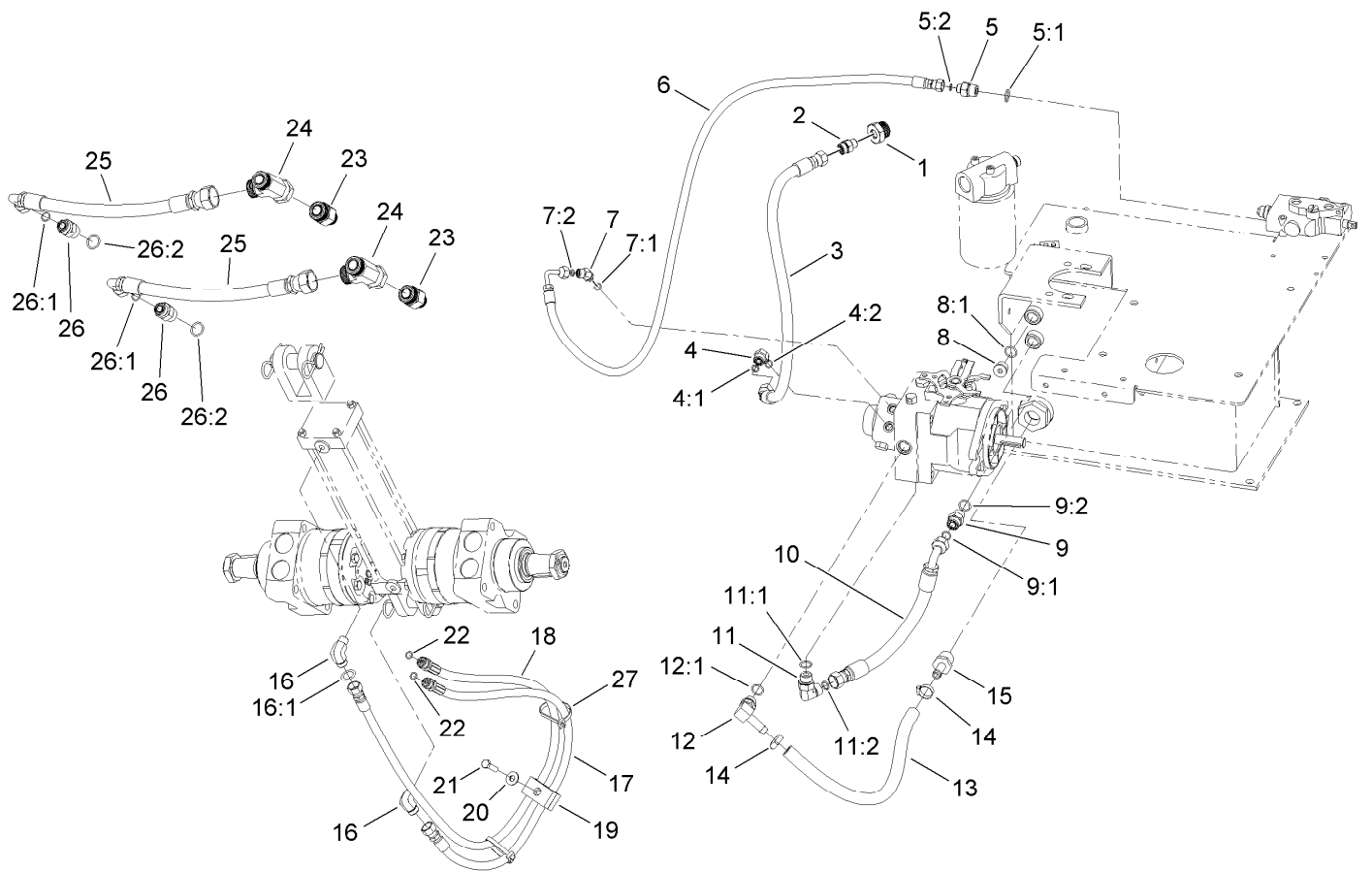

Hydraulic Hose and Fitting Assembly

Ref.	Part Number	Qty.	Description	Ref.	Part Number	Qty.	Description
1	ST50971	1	Fitting-HYD	11:2	237-30	1	O-Ring
2	ST46679	1	Fitting-HYD	12	354-120	1	Fitting-HYD, 90 DEG
3	125-8561	1	HYD Hose ASM	12:1	237-79	1	O-Ring
4	340-54	1	Elbow-45 DEG	13	98-8153	1	Hose-Return
4:1	237-22	1	O-Ring	14	2412-141	2	Clamp-Drive, Worm
4:2	237-78	1	O-Ring	15	ST37528	1	Fitting-HYD
5	340-133	1	Adapter ASM	16	340-112	2	Fitting-Elbow, 90
5:1	237-79	1	O-Ring	16:1	237-22	1	O-Ring
5:2	237-21	1	O-Ring	17	125-8569	1	HYD Hose ASM
6	125-8562	1	HYD Hose ASM	18	125-8570	1	HYD Hose ASM
7	340-103	1	Fitting-HYD, 45 DEG	19	ST37529	1	Clamp-Twin
7:1	237-78	1	O-Ring	20	3256-3	1	Washer-Flat
7:2	237-21	1	O-Ring	21	322-6	1	Screw-HH
8	353-988	1	Plug-Hex	22	237-22	2	O-Ring
8:1	237-79	1	O-Ring	23	ST50973	2	Fitting-HYD
9	340-4	1	Fitting-HYD, Straight	24	ST50975	2	Fitting-HYD
9:1	237-30	1	O-Ring	25	125-8559	2	HYD Hose ASM
9:2	237-79	1	O-Ring	26	340-6	2	Fitting-HYD, Straight
10	125-8560	1	HYD Hose ASM	26:1	237-30	1	O-Ring
11	340-98	1	Fitting-HYD, 90 DEG	26:2	237-80	1	O-Ring
11:1	237-79	1	O-Ring	27	1-303335	3	Tie-Plastic

Notes:

Notes:

Notes:



Count on it.