



Count on it.

Operator's Manual

SGR-13 Stump Grinder

Model No. 22615—Serial No. 316000001 and Up

Model No. 22615G—Serial No. 316000001 and Up

Model No. 22615HD—Serial No. 316000001 and Up

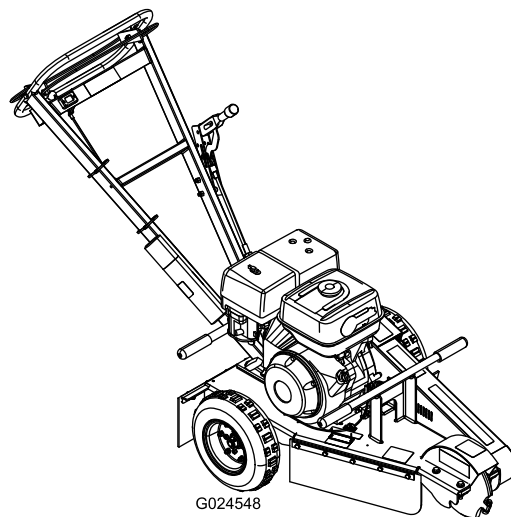

G024548



WARNING

CALIFORNIA Proposition 65 Warning

The engine exhaust from this product contains chemicals known to the State of California to cause cancer, birth defects, or other reproductive harm.

▲ DANGER

There may be buried power, gas, and/or telephone lines in the work area. Shock or explosion may occur if you dig into them.

Have the property or work area marked for buried lines and do not dig in marked areas. Contact your local marking service or utility company to have the property marked (for example, in the United States, call 811 for the nationwide marking service).

This spark ignition system complies with Canadian ICES-002.

Because in some areas there are local, state, or federal regulations requiring that a spark arrester be used on the engine of this machine, a spark arrester is available as an option. If you require a spark arrester, contact your Authorized Toro Service Dealer.

Genuine Toro spark arresters are approved by the USDA Forestry Service.

It is a violation of California Public Resource Code Section 4442 or 4443 to use or operate the engine on any forest-covered, brush-covered, or grass-covered land unless the engine is equipped with a spark arrester, as defined in Section 4442, maintained in effective working order or the engine is constructed, equipped, and maintained for the prevention of fire.

The enclosed *Engine Owner's Manual* is supplied for information regarding the US Environmental Protection Agency (EPA) and the California Emission Control Regulation of emission systems, maintenance, and warranty. Replacements may be ordered through the engine manufacturer.

Introduction

This machine is designed to grind and remove tree stumps and surface roots. It is not intended to cut rock or any other material other than wood and the soil around a stump.

Read this information carefully to learn how to operate and maintain your product properly and to avoid injury and product damage. You are responsible for operating the product properly and safely.

You may contact Toro directly at www.Toro.com for product and accessory information, help finding a dealer, or to register your product.

Whenever you need service, genuine Toro parts, or additional information, contact an Authorized Service Dealer or Toro Customer Service and have the model and serial numbers of your product ready. [Figure 1](#) illustrates the location of the model and serial numbers on the product. Write the numbers in the space provided.

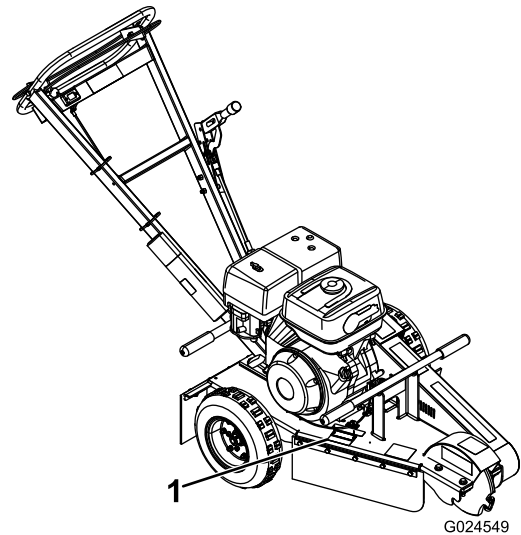

Figure 1

1. Model and serial number plate

Model No. _____

Serial No. _____

This manual identifies potential hazards and has safety messages identified by the safety-alert symbol ([Figure 2](#)), which signals a hazard that may cause serious injury or death if you do not follow the recommended precautions.



Figure 2

1. Safety-alert symbol

This manual uses 2 words to highlight information.

Important calls attention to special mechanical information and **Note** emphasizes general information worthy of special attention.

Contents

Safety	3
Safe Operating Practices	3
Safety and Instructional Decals	5
Product Overview	7
Controls	7
Specifications	8
Operation	8
Before you Start	8
Adding Fuel.....	9
Checking the Engine-Oil Level.....	10
Starting and Shutting Off the Engine.....	10
Grinding a Stump.....	11
Maintenance	13
Recommended Maintenance Schedule(s)	13
Lubrication	13
Greasing the Machine	13
Engine Maintenance	14
Servicing the Air Cleaner.....	14
Servicing the Engine Oil.....	15
Servicing the Spark Plug.....	15
Brake Maintenance	16
Adjusting the Parking Brake.....	16
Belt Maintenance	17
Adjusting the Drive-Belt Tension.....	17
Replacing the Drive Belt.....	17
Grinder Maintenance.....	18
Replacing the Teeth	18
Cleaning	19
Removing Debris from the Machine.....	19
Storage	19
Storing the Machine.....	19
Troubleshooting	20

Safety

Improper use or maintenance by the operator or owner can result in injury. To reduce the potential for injury, comply with these safety instructions and always pay attention to the safety alert symbol , which means: *Caution, Warning, or Danger*—personal safety instruction. Failure to comply with the instruction may result in personal injury or death.

Safe Operating Practices

This product is capable of amputating hands and feet. Always follow all safety instructions to avoid serious injury or death.

WARNING

Engine exhaust contains carbon monoxide, an odorless, deadly poison that can kill you.

Do not run the engine indoors or in an enclosed area.

Training

- Read the *Operator's Manual* and other training material. If the operator(s) or mechanic(s) can't read English, it is the owner's responsibility to explain this material to them.
- Become familiar with the safe operation of the equipment, operator controls, and safety signs.
- All operators and mechanics should be trained. The owner is responsible for training the users.
- Never let children or untrained people operate or service the equipment. Local regulations may restrict the age of the operator.
- The owner/user can prevent and is responsible for accidents or injuries occurring to himself or herself, other people or property.

Preparation

- Wear appropriate clothing including gloves, eye protection, long pants, substantial slip-resistant footwear, and hearing protection. Tie back long hair and do not wear jewelry.
- Inspect the area where the equipment is to be used and remove all objects such as rocks, toys, and wire which can be thrown by the machine.
- Use extra care when handling fuels. They are flammable and vapors are explosive.
 - Use only an approved container
 - Never remove the fuel cap or add fuel with the engine running. Allow the engine to cool before refueling. Do not smoke.
 - Never refuel or drain the machine indoors.

- Check that the operator presence controls, safety switches, and shields are attached and functioning properly. Do not operate unless they are functioning properly.
- Check that the cutting wheel has stopped rotating when you reduce the throttle.
- Locate the pinch point areas marked on the machine and keep hands and feet away from these areas.
- Lightning can cause severe injury or death. If lightning is seen or thunder is heard in the area, do not operate the machine; seek shelter.

Operation

- Never run an engine in an enclosed area.
- Only operate in good light, keeping away from holes and hidden hazards.
- Be sure all drives are in neutral before starting the engine. Only start the engine from the operator's position.
- Never operate with the guards not securely in place. Be sure all interlocks are attached, adjusted properly, and functioning properly.
- Do not change the engine governor setting or overspeed the engine.
- Stop the machine on level ground, lower the grinder, and shut off the engine before leaving the operator's position for any reason.
- Keep hands and feet away from the moving grinder wheel and teeth.
- Keep pets and bystanders away.
- Do not operate the machine while ill, tired, or under the influence of alcohol or drugs.
- Use care when loading or unloading the machine into a trailer or truck.
- Ensure that the area is clear of other people before operating the machine. Shut off the machine if anyone enters the area.
- Never leave a running machine unattended. Always shut off the engine and verify the cutting wheels has stopped rotating.
- Never jerk the controls; use a steady motion.
- Watch for traffic when operating near or crossing roadways.
- Do not touch parts which may be hot from operation. Allow them to cool before attempting to maintain, adjust, or service.
- Ensure that you operate the machine in areas where there are no obstacles in close proximity to the operator. Failure to maintain adequate distance from trees, walls, and other barriers may result in injury as the machine backs up during operation if the operator is not attentive to the surroundings. Only operate the unit in areas where there is sufficient clearance for the operator to safely maneuver the product.
- Before grinding, have the area marked for underground utilities, and do not grind in marked areas.

Maintenance and Storage

- Shut off the engine. Wait for all movement to stop before adjusting, cleaning, or repairing.
- Clean debris from the grinder, drives, mufflers, and engine to help prevent fires. Clean up oil or fuel spillage.
- Let the engine cool before storing and do not store near flame.
- Do not store fuel near flames or drain indoors.
- Park the machine on level ground. Never allow untrained personnel to service the machine.
- Carefully release pressure from components with stored energy.
- Remove the spark plug wire before making any repairs.
- Keep hands and feet away from moving parts. If possible, do not make adjustments with the engine running.
- Keep all parts in good working condition and all hardware tightened. Replace all worn or damaged decals.
- Keep nuts and bolts tight. Keep equipment in good condition.
- Never tamper with safety devices.
- Keep the machine free of grass, leaves, or other debris build-up. Clean up oil or fuel spillage. Allow the machine to cool before storing.
- Use extra care when handling fuels. They are flammable and vapors are explosive.
 - Use only an approved container.
 - Never remove the fuel cap or add fuel when the engine is running. Allow the engine to cool before refueling. Do not smoke.
 - Never refuel the machine indoors.
 - Never store the machine or fuel container inside where there is an open flame, such as near a water heater or furnace.
 - Never fill a container while it is inside a vehicle, trunk, pick-up bed, or any surface other than the ground.
 - Keep container nozzle in contact with the tank during filling.
- Stop and inspect the equipment if you strike an object. Make any necessary repairs before restarting.
- Use only genuine Toro replacement parts to ensure that original standards are maintained.

Safety and Instructional Decals



Safety decals and instructions are easily visible to the operator and are located near any area of potential danger. Replace any decal that is damaged or lost.

CALIFORNIA SPARK ARRESTER WARNING
 Operation of this equipment may create sparks that can start fires around dry vegetation. A spark arrester may be required. The operator should contact local fire agencies for laws or regulations relating to fire prevention requirements. 117-2718

117-2718

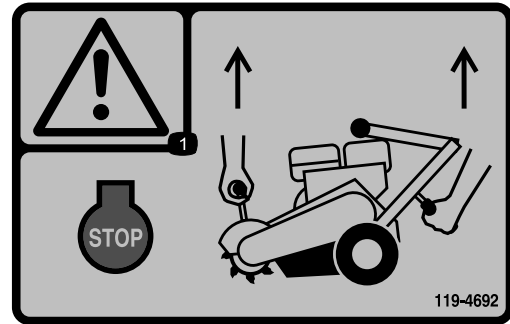

119-4692

1. Warning—shut off the engine; use both hand holds to lift the grinder.

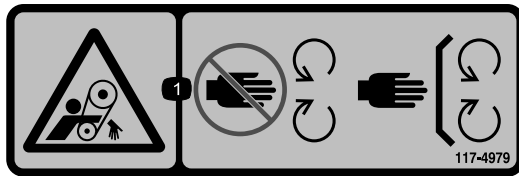

117-4979

1. Entanglement hazard, belt—stay away from moving parts, keep all guards and shields in place.



119-4693

1. Thrown object hazard—keep bystanders a safe distance from the machine.

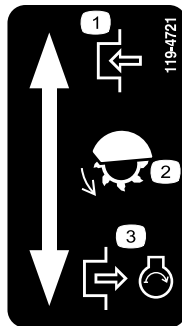

119-4721

1. Engage
2. Grinding teeth
3. Disengage, engine runs

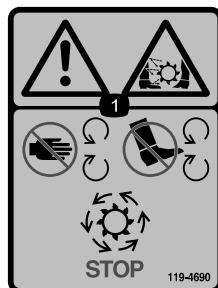

119-4690

1. Warning; cutting/dismemberment hazard, grinding teeth—keep hands and feet away from all moving parts, keep all shields in place; wait for all moving parts to stop.

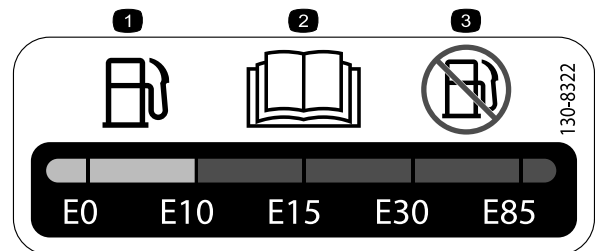

130-8322

1. Only use fuel with an alcohol content by volume under 10%.
2. Read the *Operator's Manual* for more information on fuel.
3. Do not use fuel with an alcohol content by volume greater than 10%.

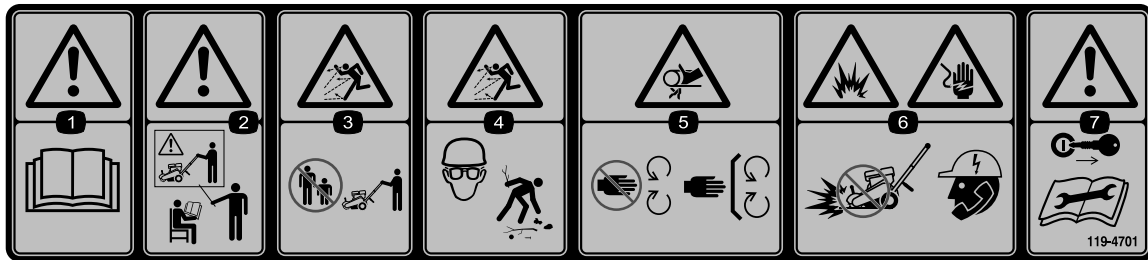

119-4701

1. Warning—read the *Operator's Manual*.
2. Warning—do not operate this machine unless you are trained.
3. Thrown object hazard—keep bystanders a safe distance from the machine.
4. Thrown object hazard—wear eye protection, pick up debris before operating.
5. Crushing hazard of hand—stay away from moving parts, keep all guards and shields in place.
6. Explosion hazard; electrical shock hazard—do not dig in areas with buried utility lines; contact local power organizations before digging.
7. Warning—remove the ignition key (if applicable) and read the instructions before servicing or performing maintenance.

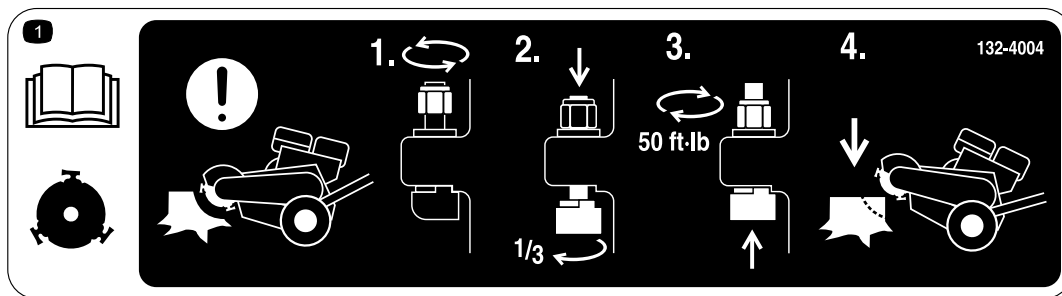

132-4004

1. Warning, cutting wheel—to adjust the cutting wheel teeth between jobs 1) Loosen the nut; 2) Push the tooth down and rotate it 1/3 of a turn; 3) Tighten the nut to 50 ft-lb; 4) Proceed with grinding.

Product Overview

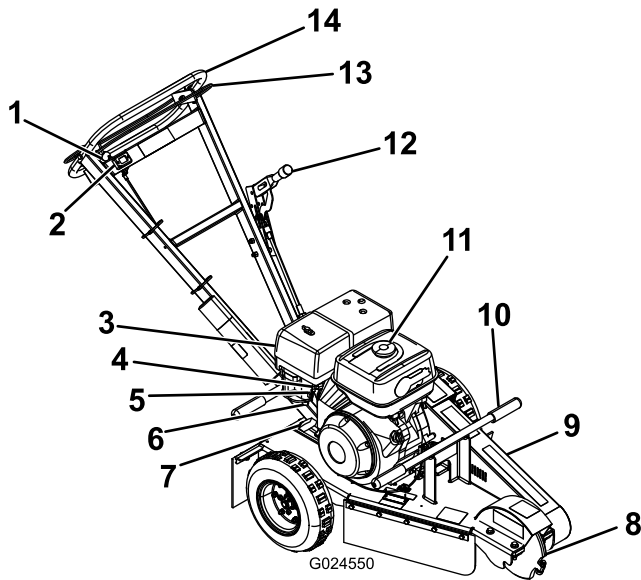

Figure 3

- | | |
|-----------------------|-------------------|
| 1. Throttle lever | 8. Cutting wheel |
| 2. Hour meter | 9. Belt cover |
| 3. Cyclone air filter | 10. Lift |
| 4. Choke | 11. Fuel cap |
| 5. Fuel valve | 12. Parking brake |
| 6. Sediment cup | 13. Safety bail |
| 7. Starter | 14. Handle |

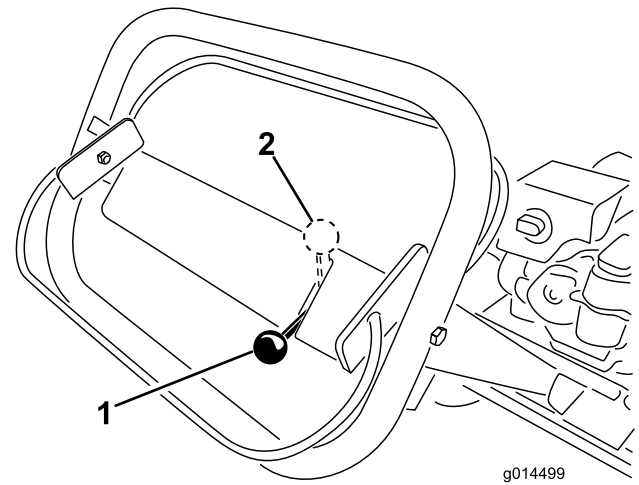

Figure 4

- | | |
|--------------------------------|------------------------------|
| 1. Throttle—Disengage position | 2. Throttle—Engaged position |
|--------------------------------|------------------------------|

Controls

Become familiar with all the controls ([Figure 3](#) and [Figure 4](#)) before you start the engine and operate the machine.

Throttle Lever

The throttle lever controls engine speed. With the lever down, in the **DISENGAGE** position, the engine runs at idle. This is also the starting position. When the engine speed increases, to the **ENGAGED** position, the centrifugal clutch engages and the cutting wheel rotates.

Parking Brake

The parking brake holds the left wheel from turning to secure the machine and for easy movement of the machine from side to side when grinding the stump.

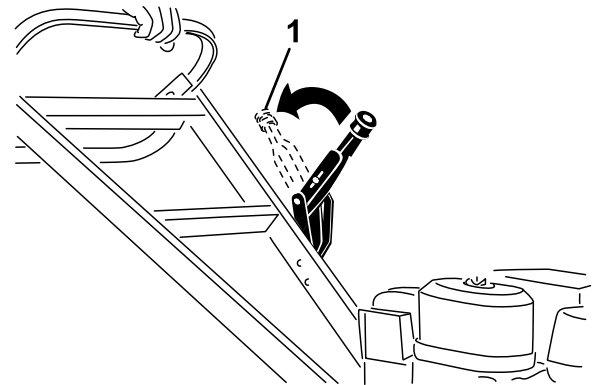

Figure 5

1. Pull back to engage brake

Hour Meter

When the engine is off, the hour meter displays the number of hours of operation that have been logged on the machine.

Specifications

Note: Specifications and design are subject to change without notice.

Cutting Depth	30 cm (12 inches)
Length	193 cm (76 inches)
Width	75 cm (29.5 inches)
Height	107 cm (42 inches)
Weight	109 Kg (240 lb)

Operation

Note: Determine the left and right sides of the machine from the normal operating position.

Important: Before operating, check the fuel and oil level, and remove debris from the machine. Also, ensure that the area is clear of people and debris. You should also know and have marked the locations of all utility lines.

Before you Start

- Dig away the earth and remove any stones near the tree stump that may interfere with your work. Check that the ground is free of foreign objects, such as electrical cables, barbed wire, etc.
- Cut or trim the stump using a power saw.
- Review all the safety decals on the machine.
- Ensure that you are familiar with safety regulations and shutdown procedures described in this manual.
- Ensure that all guards are in place and in good condition.
- Ensure that the blades and cutters are in place and in good condition.
- Ensure that the work area, cutter, and stump in particular are free from metallic objects such as wire, nails, etc. that could be thrown out and injure persons in the vicinity and damage the equipment.

Adding Fuel

Use unleaded fuel (87 pump octane minimum). Leaded, regular fuel may be used if unleaded is not available.

⚠ DANGER

In certain conditions, fuel is extremely flammable and highly explosive. A fire or explosion from fuel can burn you and others and can damage property.

- Fill the fuel tank outdoors, in an open area, when the engine is cold. Wipe up any fuel that spills.
- Never fill the fuel tank inside an enclosed trailer.
- Do not fill the fuel tank completely full. Add fuel to the fuel tank until the level is 6 to 13 mm (1/4 to 1/2 inch) below the bottom of the filler neck. This empty space in the tank allows fuel to expand.
- Never smoke when handling fuel, and stay away from an open flame or where fuel fumes may be ignited by a spark.
- Store fuel in an approved container and keep it out of the reach of children. Never buy more than a 30-day supply of fuel.
- Do not operate without the entire exhaust system in place and in proper working condition.

⚠ DANGER

In certain conditions during fueling, static electricity can be released causing a spark, which can ignite the fuel vapors. A fire or explosion from fuel can burn you and others and can damage property.

- Always place fuel containers on the ground away from your vehicle before filling.
- Do not fill fuel containers inside a vehicle or on a truck or trailer bed because interior carpets or plastic truck bed liners may insulate the container and slow the loss of any static charge.
- When practical, remove gas-powered equipment from the truck or trailer and refuel the equipment with its wheels on the ground.
- If this is not possible, then refuel such equipment on a truck or trailer from a portable container, rather than from a fuel-dispenser nozzle.
- If you must use a fuel-dispenser nozzle, keep the nozzle in contact with the rim of the fuel tank or container opening at all times until fueling is complete.

Important: Do not use methanol, fuel containing methanol, or gasohol containing more than 10% ethanol

because the fuel system could be damaged. Do not mix oil with fuel.

Using Stabilizer/Conditioner

Use a fuel stabilizer/conditioner in the machine to provide the following benefits:

- Keeps fuel fresh during storage of 90 days or less. For longer storage it is recommended that the fuel tank be drained.
- Cleans the engine while it runs.
- Eliminates gum-like varnish buildup in the fuel system, which causes hard starting.

Important: Do not use fuel additives containing methanol or ethanol.

Add the correct amount of gas stabilizer/conditioner to the gas.

Note: A fuel stabilizer/conditioner is most effective when mixed with fresh fuel. To minimize the chance of varnish deposits in the fuel system, use fuel stabilizer at all times.

Filling the Fuel Tank

1. Park the machine on a level surface, lower the grinder, and shut off the engine.
2. Allow the engine to cool.
3. Clean around the fuel-tank cap and remove it (Figure 6).

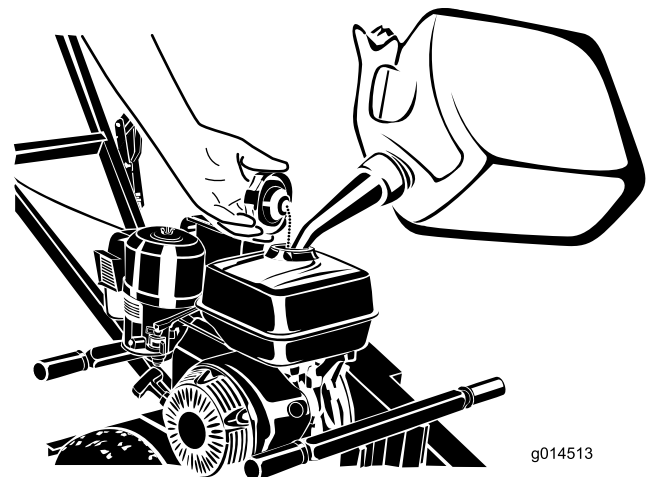

Figure 6

1. Fuel-tank cap
 4. Add fuel to the fuel tank, until the level is 6 to 13 mm (1/4 to 1/2 inch) below the bottom of the filler neck.
- Important:** This space in the tank allows fuel to expand. Do not fill the fuel tank completely full.
5. Install the fuel-tank cap securely.
 6. Wipe up any fuel that may have spilled.

Checking the Engine-Oil Level

Service Interval: Before each use or daily

1. Tilt the machine so the engine is level, and shut off the engine.
2. Allow the engine to cool.
3. Clean around the oil dipstick.
4. Remove the dipstick and wipe the end clean.
5. Slide the dipstick fully into the dipstick tube without threading it into the filler neck.
6. Pull the dipstick out and look at the end.

Note: The oil should be to the top of the upper limit range (Figure 7).

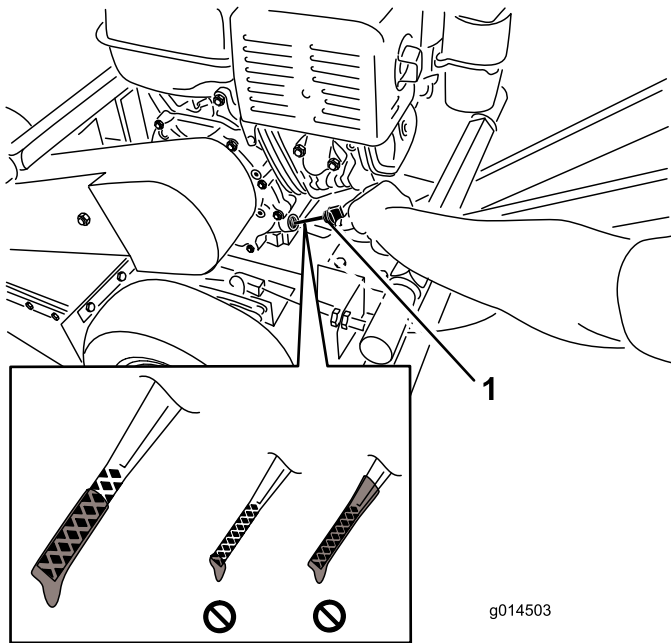

Figure 7

1. Oil dipstick

Important: Running the engine with a low oil level can cause engine damage. This type of damage is not covered by warranty.

The engine is equipped with an oil alert system that automatically shuts off the engine before the oil level falls below the safe limit.

7. If the oil level is low, slowly pour only enough oil into the crankcase to raise the level to the upper limit.

Important: Do not overfill the crankcase with oil because the engine may be damaged.

8. Replace the dipstick.

Starting and Shutting Off the Engine

Starting the Engine

1. Move the fuel valve to the OPEN position, all the way to the right.

Note: If your model is equipped with an engine with an On/Off switch, move the switch to the ON position.

2. Move the choke lever left to the ON position if you are starting a cold engine.

Note: A warm or hot engine may not require choking.

3. Move the throttle to the DISENGAGE position.
4. Hold the safety bail against the handle and push the handle down enough to raise the cutting wheel off the ground.
5. Pull the starter handle lightly until you feel resistance, then pull the handle briskly. Return the starter handle gently.
6. After the engine starts, gradually move the choke lever back to the OFF position.

Note: If the engine stalls or hesitates, move the choke back to the ON position again until the engine warms up. Then move it to the OFF position.

Shutting Off the Engine

1. Move the throttle to the DISENGAGE position.

Note: If the engine has been working hard or is hot, let it run for a minute before releasing the safety bail. This helps to cool the engine before shutting off. In an emergency, the engine may be shut off immediately.

2. Release the safety bail to shut off the engine.
3. Move the fuel valve to the CLOSED position, all the way to the left.

Note: If your model is equipped with an engine with an On/Off switch, move the switch to the OFF position.

Grinding a Stump

⚠ DANGER

The machine will cut and amputate hands and feet.

- Stay in the operator's position while the machine is running and keep away from the cutting wheel.
- Keep all bystanders a safe distance from the machine. Shut off the machine immediately if any people or animals enter the work area.
- Never leave a running machine unattended. Always shut off the engine and verify the cutting wheel has stopped rotating.

⚠ WARNING

Grinding a stump throws wood chips, soil, and other debris into the air, which could injure you or bystanders.

- Always wear eye protection and a hard hat when using the machine.
 - Ensure that everyone, including children and animals, maintain a distance of at least 15 m (50 feet) from the machine.
1. Set throttle to the DISENGAGE position, start the engine, and allow the machine to warm up for 2 minutes.
 2. Push the handle down enough to raise the cutting wheel off the ground (Figure 8).

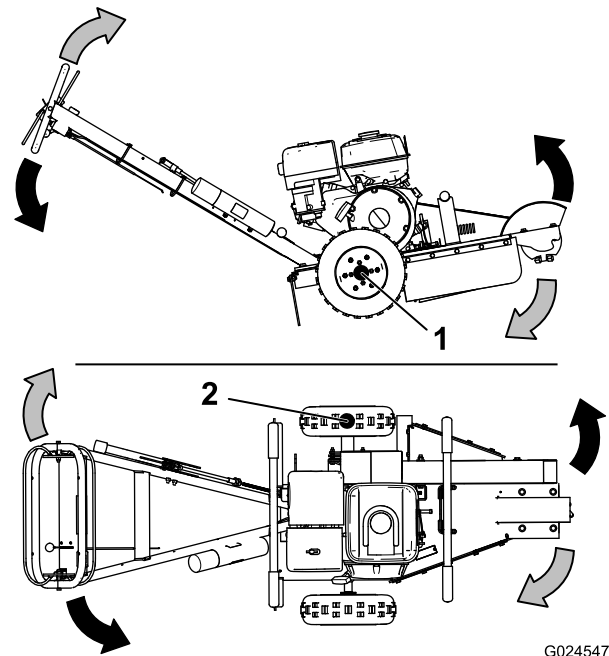

G024547

Figure 8

1. Pivot point
2. Pivot point when the parking brake is engaged

3. Move the machine to the front of the stump and set the parking brake.
4. Move throttle up to the ENGAGE position. The cutting wheel will begin rotating.
5. Swing the cutting wheel to 1 side (Figure 8), then lower it approximately 1 to 2.5 cm (1/2 to 1 inch) into the front-top corner of the stump. Swing the cutting wheel back and forth, lowering the cutting wheel approximately 1 to 2.5 cm (1/2 to 1 inch) before each sweep, until you have removed the front portion of the stump to ground level (A through D in Figure 9).



g024062

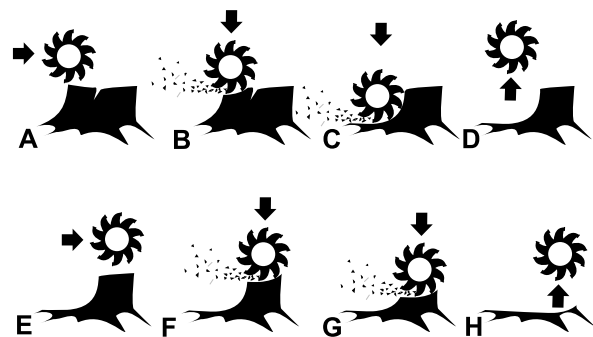

Figure 9

6. Raise the cutting wheel, release the parking brake, and move the machine forward a few centimeters (inches). Set the parking brake.
7. Repeat steps 5 and 6 until you have completely removed the stump (E through H in [Figure 9](#)).
8. Move throttle to the DISENGAGE position, push the handle down enough to raise the cutting wheel off the ground. Wait for the cutting wheel to stop rotating then release the parking brake and pull the machine away from the stump.

Note: Do not let the front of the unit touch the ground until you are sure the cutting wheel has stopped turning.

9. Shut off the engine; refer to [Shutting Off the Engine](#) (page 10).

Maintenance

Note: Determine the left and right sides of the machine from the normal operating position.

Important: You can tip the machine backward or on its side to clean or service it, but no longer than 2 minutes. If you hold the machine this position for too long, fuel can drain into the crankcase and damage the engine. Should this happen, perform an extra oil change on the engine. Then turn the engine over a few revolutions with the starter handle before starting the engine again.

Recommended Maintenance Schedule(s)

Maintenance Service Interval	Maintenance Procedure
After the first 25 hours	<ul style="list-style-type: none"> • Change the oil.
Before each use or daily	<ul style="list-style-type: none"> • Check the engine-oil level. • Grease the machine. • Check the air filter. • Check the drive belt tension. • Check the condition of the teeth; rotate or replace any that are worn or damaged and torque the nuts for all teeth. • Remove debris from the machine.
Every 50 hours	<ul style="list-style-type: none"> • Service the air filter.
Every 100 hours	<ul style="list-style-type: none"> • Change the oil (more frequently when conditions are extremely dusty or sandy). • Clean the sediment cup. • Check the spark plugs. • Replace the drive belt.
Every 200 hours	<ul style="list-style-type: none"> • Replace the air filter.
Yearly or before storage	<ul style="list-style-type: none"> • Change the oil. • Clean the sediment cup.

Important: Refer to your engine owner’s manual for additional maintenance procedures.

Lubrication

Greasing the Machine

Service Interval: Before each use or daily

Grease Type: General-purpose grease.

1. Clean the grease fittings with a rag.
2. Connect a grease gun to each fitting.
3. Lubricate 2 fittings, 1 on each cutting wheel bearing.
4. Pump grease into the fittings until grease begins to ooze out of the bearings (approximately 3 pumps).
5. Wipe up any excess grease.

Important: Pump grease in slowly and carefully to prevent damage to the bearing seals.

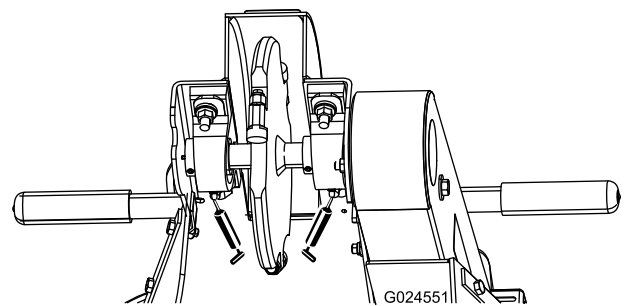

Figure 10

Engine Maintenance

Servicing the Air Cleaner

Service Interval: Before each use or daily

The cyclone air filter collects the largest contaminant particles, which collect in the container. When you can see a layer of dirt at the bottom of the container, clean the cyclone housing, air channels, and air-intake screen.

Servicing the Cyclone Air Filter

Service Interval: Every 50 hours

1. Remove the 3 screws holding the cyclone housing.
2. Remove the housing with the air-intake screen and remove the air channels.

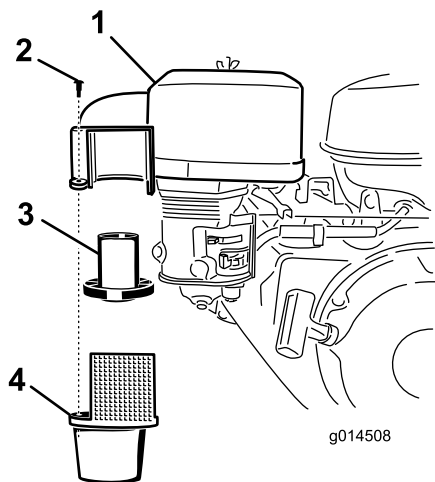

Figure 11

- | | |
|--------------------|---|
| 1. Cyclone housing | 3. Air channels |
| 2. Screw | 4. Cyclone housing with air-intake screen |

Note: The air channels may remain in the upper portion or follow along with the housing when removed.

3. Clean the components with water, detergent and a brush, then dry the components carefully.
4. Place the air channels in the cyclone housing.
5. Insert cyclone housing into position and make sure it fits in the upper portion. **Do not** use force; align it in place before fitting the screws.

Replacing the Air Filter

Service Interval: Every 200 hours

If the engine is low on power, produces black smoke, or runs unevenly, the air filter may be clogged.

1. Remove the wing nut and lift off the cyclone filter with the air filter cowl (Figure 12).

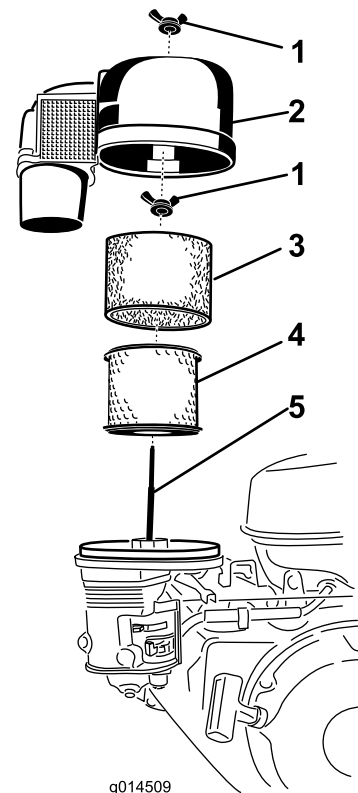

Figure 12

- | | |
|-----------------------|---------------|
| 1. Wing nut | 4. Air filter |
| 2. Cyclone air filter | 5. Stud |
| 3. Foam pre-filter | |

2. Remove the foam pre-filter and clean it as follows
 - A. Wash the pre-filter using a mild detergent and water.
 - B. Squeeze it dry with a clean cloth.
 - C. Soak it with new engine oil.
 - D. Gently wind the filter in an absorbent cloth and squeeze out excess oil.
 3. Remove the wing nut on top of the air filter and remove the paper filter.
 4. Tap the paper filter against a fixed surface to remove dust. If the paper filter is still dirty or damaged, replace it.
- Important:** Do not use compressed air to blow out the paper element, this can damage it.
5. Mount the paper filter in the air filter housing and secure it with the wing nut.
 6. Position the foam pre-filter over the paper filter.
 7. Install the cyclone filter with the air filter cover and secure it with the wing nut.

Servicing the Engine Oil

Oil Type: Detergent oil with an API service of SJ or higher.

Crankcase Capacity: 2 L (2.1 qt)

Viscosity: SAE 10W-30 is recommended for general use.

Changing the Engine Oil

Service Interval: After the first 25 hours

Every 100 hours

Yearly or before storage

1. Start the engine and let it run 5 minutes.

Note: This warms the oil so it drains better.

2. Park the machine so that the drain side is slightly lower than the opposite side to ensure that the oil drains completely.
3. Set the parking brake and shut off the engine.
4. Place a pan under the oil-drain hole.
5. Remove the drain plug and drain the oil through the hole slot in the frame (Figure 13).

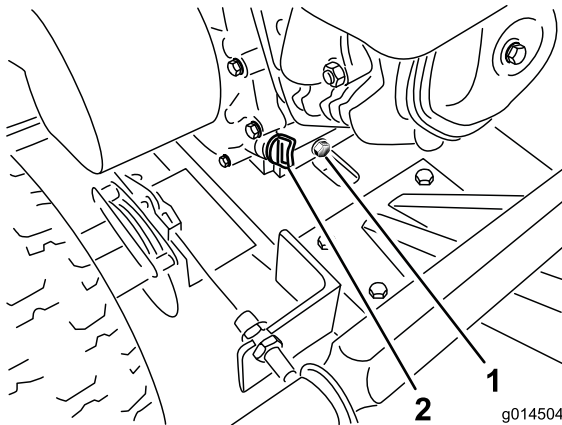

Figure 13

1. Oil-drain hole
2. Oil-fill cap

6. When the oil has drained completely, install the plug and wipe up any spilled oil.

Note: Dispose of the used oil at a certified recycling center.

7. Remove the oil fill cap and slowly pour approximately 80% of the specified amount of oil into the engine (Figure 13).
8. Slowly add additional oil to bring the oil level to the upper limit mark on the dipstick. Refer to [Checking the Engine-Oil Level](#) (page 10).
9. Install the oil-fill cap.

Cleaning the Sediment Cup

Service Interval: Every 100 hours

Yearly or before storage

Underneath the fuel valve is a sediment cup to catch dirt in the fuel.

1. Move the fuel valve to the OFF position, all the way to the left.
2. Unscrew the sediment cup (Figure 14).

Note: Make sure not to misplace the O-ring.

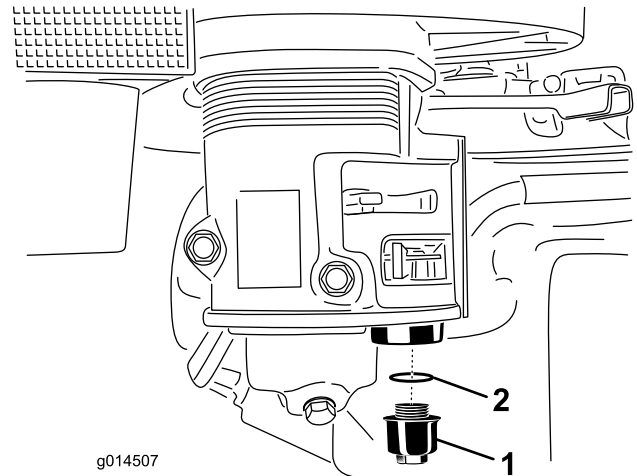

Figure 14

1. Sediment cup
2. O-Ring

3. Clean the reservoir and the O-ring using a cleaning solvent and dry carefully.

Note: Make sure not to misplace the O-ring.

4. Put the O-ring in place in the groove of the cup and replace the sediment cup.
5. Turn the fuel valve to the ON position, all the way to the right, and check for leaks. If it leaks, replace the o-ring.

Servicing the Spark Plug

Service Interval: Every 100 hours—Check the spark plugs.

Ensure that the air gap between the center and side electrodes is correct before installing the spark plug. Use a spark plug wrench for removing and installing the spark plug and a gapping tool/feeler gauge to check and adjust the air gap. Install a new spark plug if necessary.

Type: BPR6ES (NGK) or equivalent

Air Gap: 0.70 to 0.80 mm (0.28 to 0.031 inch)

Brake Maintenance

Adjusting the Parking Brake

1. Loosen the set screw on side of brake lever knob.
2. Turn the knob clockwise to tighten the brake; adjust counter clockwise to loosen the brake.

Note: The left wheel should lock completely when the brake is set.

3. Tighten the setscrew.

Removing the Spark Plug

1. Lower the grinder and shut off the machine; Refer to [Shutting Off the Engine \(page 10\)](#).
2. Pull the wire off the spark plug ([Figure 15](#)).

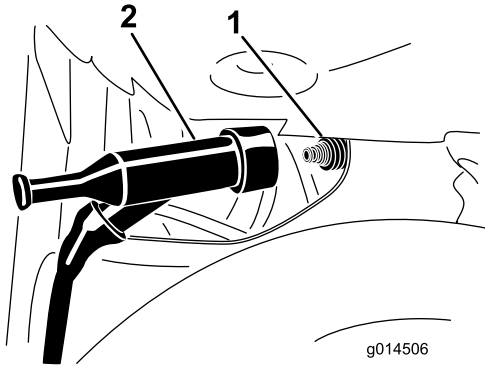

Figure 15

1. Spark plug
2. Wire

3. Clean around the spark plug.
4. Remove the spark plug and the metal washer.

Checking the Spark Plug

1. Look at the center of the spark plug ([Figure 16](#)). If you see light brown or gray on the insulator, the engine is operating properly. A black coating on the insulator usually means that the air cleaner is dirty.

Important: Never Clean the spark plug. Always replace the spark plug when it has a black coating, worn electrodes, an oily film, or cracks.

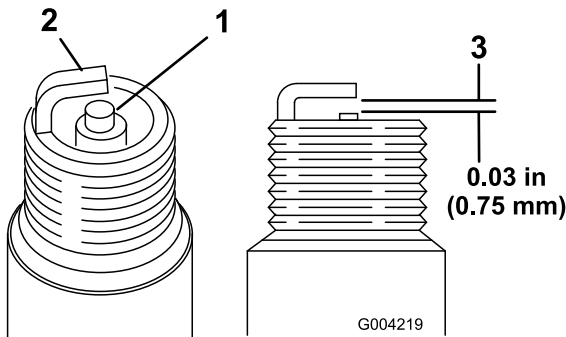

Figure 16

1. Center electrode insulator
2. Side electrode
3. Air gap (not to scale)

2. Check the gap between the center and side electrodes ([Figure 16](#)). Bend the side electrode ([Figure 16](#)) if the gap is not correct.

Installing the Spark Plug

1. Thread the spark plug into the spark plug hole.
2. Tighten the spark plug to 27 N·m (20 ft-lb).
3. Push the wire onto the spark plug.

Belt Maintenance

Adjusting the Drive-Belt Tension

Service Interval: Before each use or daily

Note: Inspect the drive belt through the slot on top of the belt cover. Adjust as required.

1. Remove the bolts and washers securing the belt guard to machine.
2. Remove the belt guard (Figure 17).

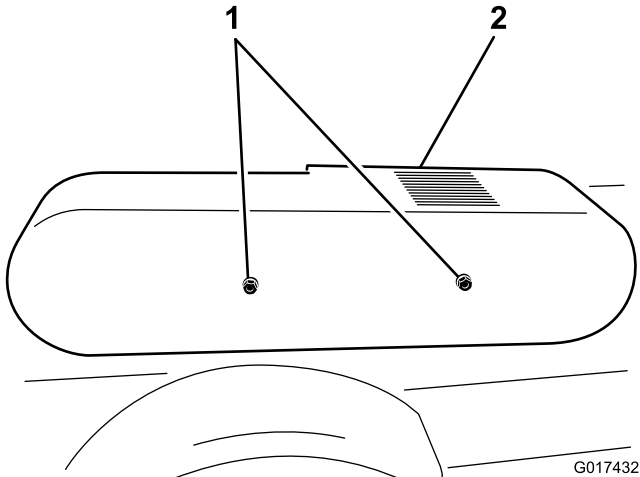

Figure 17

1. Bolts and washers
2. Belt guard

3. Loosen the 4 engine plate mounting bolts and the 4 bolts securing the rear of the belt guard to the engine.
4. Loosen the belt-tension bolt and jam nut, slide the engine toward the flywheel housing to loosen belt (Figure 18).

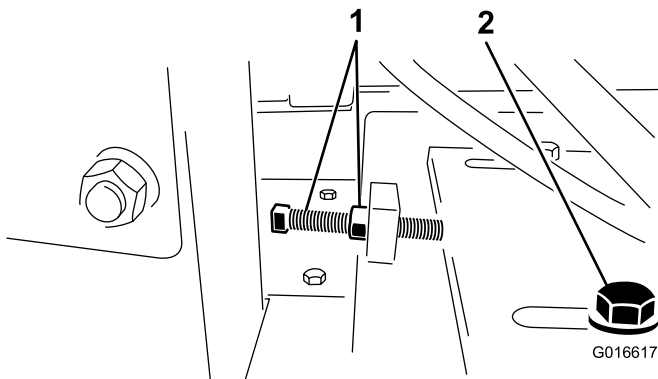

Figure 18

1. Tension bolt and jam
2. Engine plate mounting bolt

5. Adjust the drive belt tension by tightening tension bolt and jam nut against the engine mounting plate, pushing the engine rearward.

6. Lay a straightedge across clutch and flywheel pulleys, tighten belt-tension bolt so there is 1 cm (0.40 inch) of flex in the belt when pushing down with 6.8 kg (15 lb) force, at mid-span (when re-tensioning a belt in use) or with 8 kg (18 lb) force when installing a new belt (Figure 19).

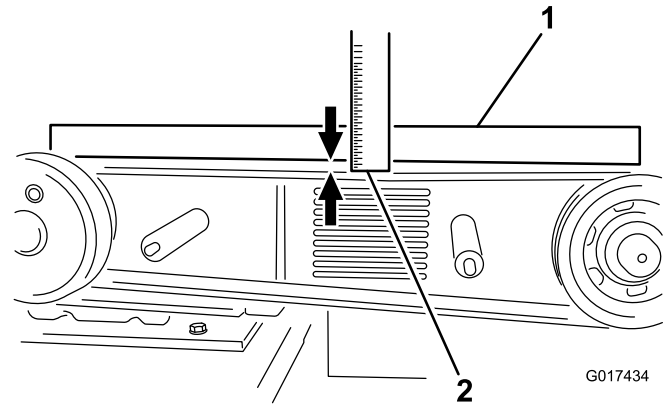

Figure 19

1. Straightedge
2. Flex of 1 cm (0.40 inch)

7. Ensure that the pulleys are aligned and the engine is parallel with the frame (not angled toward the side), then tighten the 4 engine plate mounting bolts and the 4 bolts securing the rear of the belt guard to the engine.
8. Install the belt guard and secure it with the previously removed washers and bolts.

Replacing the Drive Belt

Service Interval: Every 100 hours

Note: Replace the belt if it shows any signs of wear, cracks, glazing, or damage.

1. Remove the bolts and washers securing the belt guard to machine.
2. Remove the belt guard (Figure 17).
3. Loosen the 4 engine plate mounting bolts and the 4 bolts securing the rear of the belt guard to the engine.
4. Loosen the belt-tension bolt and jam nut, slide the engine toward the flywheel housing to loosen belt (Figure 18).
5. Replace drive belt.
6. Adjust tension of new belt to 7.6 to 8.4 kg (17.1 to 18.9 lb) force and 10 mm (0.40 inch) belt deflection at mid-span.
7. Tighten the 4 engine plate mounting bolts and the 4 bolts securing the rear of the belt guard to the engine.
8. Install the belt guard and secure it with the previously removed washers and bolts.

Grinder Maintenance

Replacing the Teeth

Service Interval: Before each use or daily—Check the condition of the teeth; rotate or replace any that are worn or damaged and torque the nuts for all teeth.

Due to the high amount of wear placed on the teeth, you need to rotate and replace them periodically (Figure 20). Before you rotate or replace them, inspect each tooth holder on the wheel, including the flat lands that prevent the teeth from rotating. If the tooth holder is damaged, replace the wheel. Torque the nuts 68 N·m (50 ft-lb) for any teeth that you are not rotating or replacing.

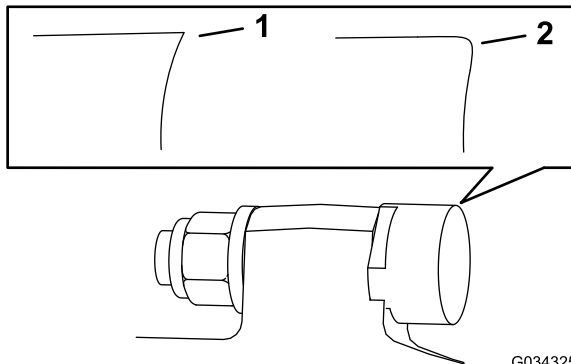

Figure 20

- 1. Sharp tooth
- 2. Worn tooth

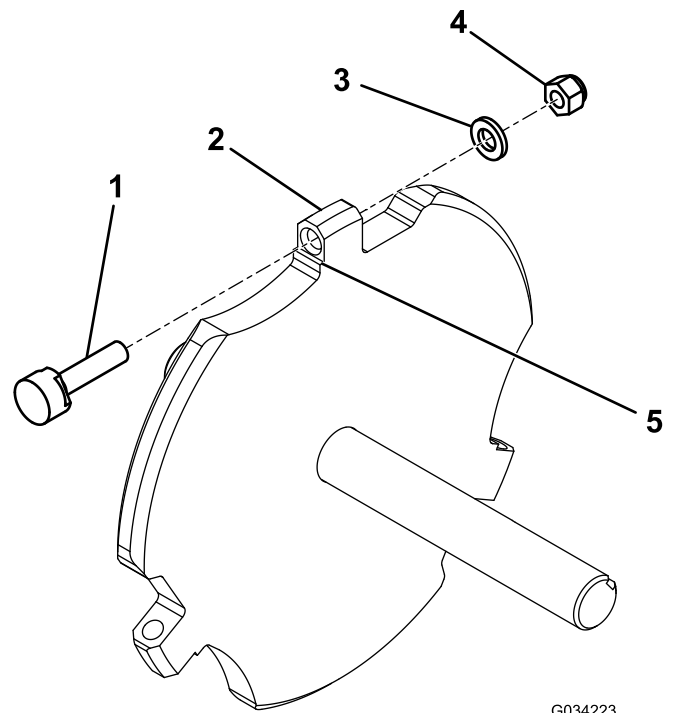

Figure 21

- 1. Tooth
- 2. Tooth holder
- 3. Washer
- 4. Nut
- 5. Flat land

Each tooth is indexed with 3 positions so you can rotate it twice, exposing a new sharp edge before replacing the tooth. To rotate a tooth, loosen the nut securing the tooth (Figure 21). Push the tooth forward and rotate it 1/3 of a turn, bringing an unused edge to the outside. Torque the nut securing the tooth to 68 N·m (50 ft-lb).

To replace a tooth, remove the nut securing the tooth, then install a new tooth, washer, and nut in the same position (Figure 21). Torque the nut securing the tooth to 68 N·m (50 ft-lb).

Cleaning

Removing Debris from the Machine

Regular cleaning and washing increases the life span of the machine. Clean the machine directly after use, before the dirt hardens.

Check before cleaning that the fuel tank cap is properly in place to avoid getting water in the tank.

Use care when using a high-pressure sprayer, because it can damage warning decals, instruction signs, and the engine

Important: Lubricate the cutting wheel bearings after cleaning.

Storage

Storing the Machine

For storage over 30 days, prepare the machine as follows:

1. Remove dirt and grime from the external parts of the entire unit, especially the engine. Clean dirt and sawdust chips from the outside of the engine cylinder head fins and blower housing.

Important: You can wash the unit with mild detergent and water.

2. Add a petroleum-based stabilizer/conditioner to fuel in the tank. Follow mixing instructions from stabilizer manufacturer. (7.8 ml per L or 1 oz per US gallon).

Note: Fuel stabilizer/conditioner is most effective when mixed with fresh fuel and used at all times.

Important: Do not use an alcohol-based stabilizer (ethanol or methanol). Do not store stabilizer/conditioned fuel over 90 days.

3. Run the engine to distribute conditioned fuel through the fuel system (5 minutes).
4. Shut off the engine, allow it to cool, and drain the fuel tank using a pump type siphon. Dispose of fuel properly; recycle as per local codes.
5. Start the engine and run it until it shuts off.
6. Choke the engine.
7. Start and run the engine until it does not start again.
8. Clean the sediment cup; refer to [Cleaning the Sediment Cup \(page 15\)](#).
9. Service the air cleaner; refer to [Servicing the Air Cleaner \(page 14\)](#) and [Replacing the Air Filter \(page 14\)](#).
10. Change the engine crankcase oil; refer to [Changing the Engine Oil \(page 15\)](#).
11. Remove the spark plug and check the condition; refer to [Servicing the Spark Plug \(page 15\)](#).
12. With the spark plug removed from the engine, pour 2 tablespoons of engine oil into the spark plug hole.
13. Pull the starter slowly to crank the engine and distribute the oil inside the cylinder.
14. Install the spark plug, but do not install the wire on the spark plug.
15. Grease the cutter wheel bearings; refer to [Greasing the Machine \(page 13\)](#).
16. Check and tighten all bolts, nuts, and screws. Repair or replace any part that is damaged.
17. Paint all scratched or bare metal surfaces. Paint is available from your Authorized Service Dealer.
18. Store the unit in a clean, dry garage or storage area.
19. Cover the unit to protect it and keep it clean.

Troubleshooting

Problem	Possible Cause	Corrective Action
The engine does not start.	<ol style="list-style-type: none"> 1. The safety bale is in the OFF position. 2. If your model is equipped with an engine with an On/Off switch, the switch is in the OFF position. 3. The fuel shutoff valve is closed. 4. The choke is open. 5. The fuel tank is empty. 6. The spark plug wire is loose or disconnected. 	<ol style="list-style-type: none"> 1. Hold the safety bail against the handle. 2. Move the switch to the ON position. 3. Open the fuel valve. 4. Close the choke when starting a cold engine. 5. Fill tank with fresh fuel. 6. Check the electrode gap and clean or replace the spark plug.
The engine runs rough.	<ol style="list-style-type: none"> 1. The choke is left on. 2. The air filter is clogged. 3. The fuel line is clogged. 4. There is water or contaminants in the fuel. 5. The spark plugs are worn or have buildup on the electrodes. 	<ol style="list-style-type: none"> 1. Open the choke. 2. Clean or replace the air filter. 3. Clean the sediment cup. 4. Drain and fill the tank with fresh fuel. 5. Check the electrode gap and clean or replace the spark plug.
The belt slips or comes off the pulleys.	<ol style="list-style-type: none"> 1. The belt tension is insufficient. 	<ol style="list-style-type: none"> 1. Adjust the belt tension. Reduce the cutting depth.
The cutting wheel does not rotate.	<ol style="list-style-type: none"> 1. The engine speed is insufficient to activate the centrifugal clutch. 2. The belt tension is insufficient. 3. The clutch shoes are worn. 	<ol style="list-style-type: none"> 1. Move the throttle to the ENGAGED position. 2. Adjust the belt tension. 3. Replace the clutch.
The cutting wheel continues to rotate.	<ol style="list-style-type: none"> 1. The engine speed is excessive. 2. The belt is off of the pulleys or broken. 3. Clutch springs are weak or broken. 	<ol style="list-style-type: none"> 1. Move the throttle to the DISENGAGED position. 2. Replace the drive belt. 3. Replace the clutch.
The parking brake does not hold.	<ol style="list-style-type: none"> 1. The parking brake is out of adjustment. 2. The brake pads are worn. 	<ol style="list-style-type: none"> 1. Adjust the parking brake. 2. Replace the brake.

Notes:

Notes:

Notes:



The Toro Warranty

A limited warranty (see warranty periods below)

SWS
Turf Renovation
and
Tree Care

Conditions and Products Covered

The Toro Company and its affiliate, Toro Warranty Company, pursuant to an agreement between them, jointly warrant your Toro Products listed below to be free from defects in materials or workmanship.

This warranty covers the cost of parts and labor, but you must pay transportation costs.

The following time periods apply from the date of purchase:

Products	Warranty Period
Turf Renovation	
Walk-Behind Aerator	1 year
• Engine	2 years
Stand-On Aerator	1 year
• Battery	90 days Parts and Labor
	1 year Parts Only
• Engine	2 years
Dethatcher	1 year
• Engine	2 years
Turf Seeder	1 year
• Engine	2 years
Tree Care	
Log Splitter	1 year
• Battery	90 days Parts and Labor
	1 year Parts Only
• Engine	2 years
Stump Grinder	1 year
• Engine	2 years
Brush Chipper	1 year
• Battery	90 days Parts and Labor
	1 year Parts Only
• Engine	3 years
Walk-Behind Rotary Broom	1 year
• Engine	2 years

Where a warrantable condition exists, we will repair the Product at no cost to you including diagnosis, labor, and parts.

Instructions for Obtaining Warranty Service

If you think that your Toro Product contains a defect in materials or workmanship, follow this procedure**:

- Contact any Authorized Servicing Outlet to arrange service at their dealership. To locate one convenient to you, access our website at www.Toro.com. Select "Where to Buy" and select "Contractor" under product type. You may also call our toll free number below.
- Bring the product and your proof of purchase (sales receipt) to them.
- If for any reason you are dissatisfied with the Service Outlet's analysis or with the assistance provided, contact us at:

SWS Customer Care Department
Toro Warranty Company
8111 Lyndale Avenue South
Bloomington, MN 55420-1196
Toll Free: 888-384-9940

**Toro Authorized Rental Customers who have purchased products directly from Toro and have signed the Toro Rental Customer Agreement have the ability to perform their own warranty work. Please visit Toro's Rental Portal for electronic warranty claim filing procedures or call the toll free number above.

Owner Responsibilities

You must maintain your Toro Product by following the maintenance procedures described in the *Operator's Manual*. Such routine maintenance, whether performed by a dealer or by you, is at your expense. Parts scheduled for replacement as required maintenance ("Maintenance Parts"), are warranted for the period of time up to the scheduled replacement time for that part. Failure to perform required maintenance and adjustments can be grounds for disallowing a warranty claim.

Items and Conditions Not Covered

Not all product failures or malfunctions that occur during the warranty period are defects in materials or workmanship. This express warranty does not cover the following:

- Product failures which result from installation and use of add-on, modified, or unapproved accessories
- Failure to perform required maintenance and/or adjustments
- Repairs necessary due to failure to follow recommended fuel procedure (consult *Operator's Manual* for more details)
 - Removing contaminants from the fuel system is not covered
 - Use of old fuel (more than one month old) or fuel which contains more than 10% ethanol or more than 15% MTBE
 - Failure to drain the fuel system prior to any period of non-use over one month
- Product failures which result from operating the product in an abusive, negligent or reckless manner
- Parts subject to consumption through use unless found to be defective. Examples of parts which are consumed, include, belts, cutters, blades, teeth, spark plugs, tires, filters, etc.
- Failures caused by outside influence include, weather, storage, contamination, lubricants, additives, or chemicals, etc.
- Normal "wear and tear" items includes painted surfaces and scratched decals, etc.
- Any component covered by a separate manufacturer's warranty
- Pickup and delivery charges

General Conditions

Repair by an Authorized Servicing Outlet or Self-Service as an Authorized Rental Customer is your sole remedy under the warranty.

Neither The Toro Company nor Toro Warranty Company is liable for indirect, incidental or consequential damages in connection with the use of the Toro Products covered by this warranty, including any cost or expense of providing substitute equipment or service during reasonable periods of malfunction or non-use pending completion of repairs under this warranty. All implied warranties of merchantability and fitness for use are limited to the duration of this express warranty. Some states do not allow exclusions of incidental or consequential damages, or limitations on how long an implied warranty lasts, so the above exclusions and limitations may not apply to you.

This warranty gives you specific legal rights, and you may also have other rights which vary from state to state.

Except for the engine warranty coverage and the Emissions warranty referenced below, there is no other express warranty. The Emissions Control System on your Product may be covered by a separate warranty meeting requirements established by the U.S. Environmental Protection Agency (EPA) or the California Air Resources Board (CARB). Refer to the California Emission Control Warranty Statement supplied with your Product or contained in the engine manufacturer's documentation for details.

Countries Other than the United States or Canada

Customers who have purchased Toro products outside the United States or Canada should contact their Toro Distributor (Dealer) to obtain guarantee policies for your country, province, or state. If for any reason you are dissatisfied with your Distributor's service or have difficulty obtaining guarantee information, contact the Toro importer. If all other remedies fail, you may contact us at Toro Warranty Company.

Australian Consumer Law: Australian customers will find details relating to the Australian Consumer Law either inside the box or at your local Toro Dealer.