



Wheel Horse®

312-8

Garden Tractor

Model No. 73363 – 7900001 & Up

Operator's Manual

IMPORTANT: Read this manual carefully. It contains information about your safety and the safety of others. Also become familiar with the controls and their proper use before you operate the product.

Introduction

Thank you for purchasing a Toro product.

All of us at Toro want you to be completely satisfied with your new product, so feel free to contact your local Authorized Service Dealer for help with service, genuine replacement parts, or other information you may require.

Whenever you contact your Authorized Service Dealer or the factory, always know the model and serial numbers of your product. These numbers will help the Service Dealer or Service Representative provide exact information about your specific product. You will find the model and serial number plate located in a unique place on the product as shown below.

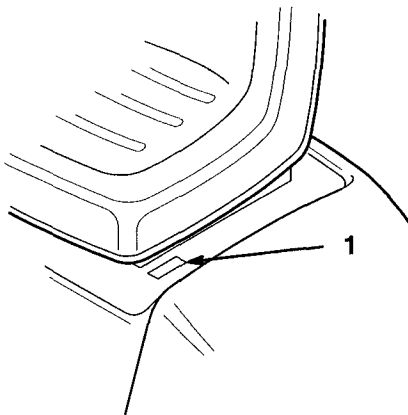

m-2345

1. Model and Serial Number Plate

For your convenience, write the product model and serial numbers in the space below.

Model No: _____
Serial No. _____

Read this manual carefully to learn how to operate and maintain your product correctly. Reading this manual will help you and others avoid personal injury and damage to the product. Although we design, produce and market safe, state-of-the-art products, you are responsible for using the product properly and safely. You are also responsible for training persons, who you allow to use the product, about safe operation.

The warning system in this manual identifies potential hazards and has special safety messages that help you and others avoid personal injury, even death. DANGER, WARNING and CAUTION are signal words used to identify the level of hazard. However, regardless of the hazard, be extremely careful.



DANGER signals an extreme hazard that will cause serious injury or death if the recommended precautions are not followed.

WARNING signals a hazard that may cause serious injury or death if the recommended precautions are not followed.

CAUTION signals a hazard that may cause minor or moderate injury if the recommended precautions are not followed.

Two other words are also used to highlight information. "Important" calls attention to special mechanical information and "Note" emphasizes general information worthy of special attention.

The left and right side of the machine is determined by sitting on the seat in the normal operator's position.

 WARNING: 
The engine exhaust from this product contains chemicals known to the State of California to cause cancer, birth defects, or other reproductive harm.

Contents

	Page		Page
Safety	2	Positioning the Seat	15
Safe Operating Practices	2	Lights	15
Slope Chart	5	Installing PTO Belt	15
Safety and Instruction Decals	7	Maintenance	16
Gasoline and Oil	8	Service Interval Chart	16
Recommended Gasoline	8	Air Cleaner	17
Stabilizer/Conditioner	8	Engine Oil	19
Filling the Fuel Tank	8	Spark Plug	21
Check Engine Oil Level	8	Greasing and Lubrication	22
Operation	9	Tire Pressure	23
Think Safety First	9	Brake	24
Controls	9	PTO (Power Take Off) Clutch and Brake ..	25
Parking Brake	9	Front Wheel Toe-In	26
Starting and Stopping the Engine	10	Fuel Tank	27
Operating the Power Take Off (PTO)	11	Transaxle Fluid	28
The Safety Interlock System	11	Headlights	29
Instruments	12	Battery	30
Driving Forward or Backward	13	Fuse	32
Selecting Ground Speeds	13	Wiring Diagram	33
Stopping the Machine	13	Cleaning and Storage	34
Attachment Lift Lever	14	Troubleshooting	35
Adjusting Dial-A-Height	14	Warranty	Back Cover

Safety

This machine meets or exceeds the B71.1–1990 specifications of the American National Standards Institute, in effect at the time of production. However, improper use or maintenance by the operator or owner can result in injury. To reduce the potential for injury, comply with these safety instructions and always pay attention to the safety alert  symbol, which means CAUTION, WARNING, or DANGER—“personal safety instruction.” Failure to comply with the instruction may result in personal injury or death.

Safe Operating Practices

This product is capable of amputating hands and feet and throwing objects. Always follow all safety instructions to avoid serious injury or death.

WARNING

POTENTIAL HAZARD

- Engine exhaust contains carbon monoxide, which is an odorless, deadly poison.

WHAT CAN HAPPEN

- Carbon monoxide can kill you and is also known to the State of California to cause birth defects.

HOW TO AVOID THE HAZARD

- Do not run engine indoors or in an enclosed area.

General Operation

1. Read, understand, and follow all instructions in the operator’s manual and on the machine before starting.
2. Allow only responsible adults who are familiar with the instructions to operate the machine.
3. Clear the area of objects such as rocks, toys, wire, etc., which could be picked up and thrown by the blade.
4. Be sure the area is clear of other people before mowing. Stop the machine if anyone enters the area.
5. Never carry passengers.
6. Do not mow in reverse unless absolutely necessary. Always look down and behind before and while backing.
7. Be aware of the mower discharge direction and do not point it at anyone. Do not operate the mower without either the entire grass catcher or the guard in place.
8. Slow down before turning. Sharp turns on any terrain may cause loss of control.
9. Never leave a running machine unattended. Always turn off blades, set parking brake, stop engine, and remove key before dismounting.
10. Turn off blades when not mowing.
11. Keep hands, feet, hair and loose clothing away from attachment discharge area, underside of mower and any moving parts while engine is running.
12. Stop the engine before removing the grass catcher or unclogging the chute.

13. Mow only in daylight or good artificial light.
14. Do not operate the machine while under the influence of alcohol or drugs.
15. Watch for traffic when operating near or crossing roadways.
16. Use extra care when loading or unloading the machine onto a trailer or truck.
17. Do not touch equipment or attachment parts which may be hot from operation. Allow to cool before attempting to maintain, adjust or service.

Slope Operation

Slopes are a major factor related to loss-of-control and tip-over accidents, which can result in severe injury or death. All slopes require extra caution. If you cannot back up the slope or if you feel uneasy on it, do not mow it.

DO

- Mow up and down slopes greater than 5°, not across.
- Mow downhill only on slopes above 10°, never mow uphill. If a steep slope must be ascended, back up the hill, and drive forward down the hill, keeping the machine in gear.
- Remove obstacles such as rocks, tree limbs, etc. from the mowing area. Watch for holes, ruts or bumps, as uneven terrain could overturn the machine. Tall grass can hide obstacles.
- Use slow speed. Choose a low gear so that you will not have to stop or shift while on the slope.
- Follow the manufacturer's recommendations for wheel weight or counterweights to improve stability.
- Use extra care with grass catchers or other attachments. These can change the stability of the machine.

- Keep all movement on slopes slow and gradual. Do not make sudden changes in speed or direction.
- Avoid starting or stopping on a slope. If tires lose traction, disengage the blades and proceed slowly straight down the slope.

DO NOT

- Do not operate machine on hillsides or slopes exceeding 15°.
- Avoid turning on slopes. If you must turn, turn slowly and gradually downhill, if possible.
- Do not mow near drop-offs, ditches, or embankments. The machine could suddenly turn over if a wheel goes over the edge of a cliff or ditch, or if an edge caves in.
- Do not mow on wet grass. Reduced traction could cause sliding.
- Do not try to stabilize the machine by putting your foot on the ground.
- Do not use a grass catcher on steep slopes. Heavy grass bags could cause loss of control or overturn the machine.

Children

Tragic accidents can occur if the operator is not alert to the presence of children. Children are often attracted to the machine and the mowing activity. Never assume that children will remain where you last saw them. The following requirements must be followed to prevent injury to children.

1. Keep children out of the mowing area and under the watchful care of another responsible adult.
2. Be alert and turn the machine off if children enter the area.
3. Before and while backing, look behind and down for small children.
4. Never carry children. They may fall off and be seriously injured or interfere with safe machine operation.
5. Never allow children to operate the machine.
6. Use extra care when approaching blind corners, shrubs, trees, the end of a fence or other objects that may obscure vision.

Service

1. Stop the engine and disconnect spark plug wire(s) before performing any service, repairs, maintenance or adjustments.
2. Use extra care when handling gasoline and other fuels. They are flammable and vapors are explosive.
 - A. Use only an approved container.
 - B. Never remove the gas cap or add fuel when the engine is running. Allow the engine to cool before refueling. Do not smoke.
 - C. Never refuel the machine indoors.
 - D. Never store the machine or fuel container inside where there is an open flame, such as near a water heater or furnace.
3. Never run a machine inside a closed area.

4. Keep nuts and bolts tight, especially the blade attachment bolts. Keep equipment in good condition.
5. Never tamper with safety devices. Check safety systems for proper operation before each use.
6. Keep the machine free of grass, leaves, or other debris build-up. Clean up oil or fuel spillage. Allow the machine to cool before storing.
7. Stop and inspect the equipment if you strike an object. Repair, if necessary, before restarting.
8. Grass catcher components are subject to wear, damage and deterioration, which could expose moving parts or allow objects to be thrown. Frequently check components and replace with manufacturer's recommended parts, when necessary.
9. Mower blades are sharp and can cut. Wrap the blade(s) or wear gloves, and use extra caution when servicing them.
10. Use only genuine replacement parts to ensure that original standards are maintained.
11. Check brake operation frequently. Adjust and service as required.
12. Battery acid is poisonous and can cause burns. Avoid contact with skin, eyes and clothing. Protect your face, eyes and clothing when working with a battery.
13. Battery gases can explode. Keep cigarettes, sparks and flames away from battery.

Slope Chart

Read all safety instructions on pages 2-4.

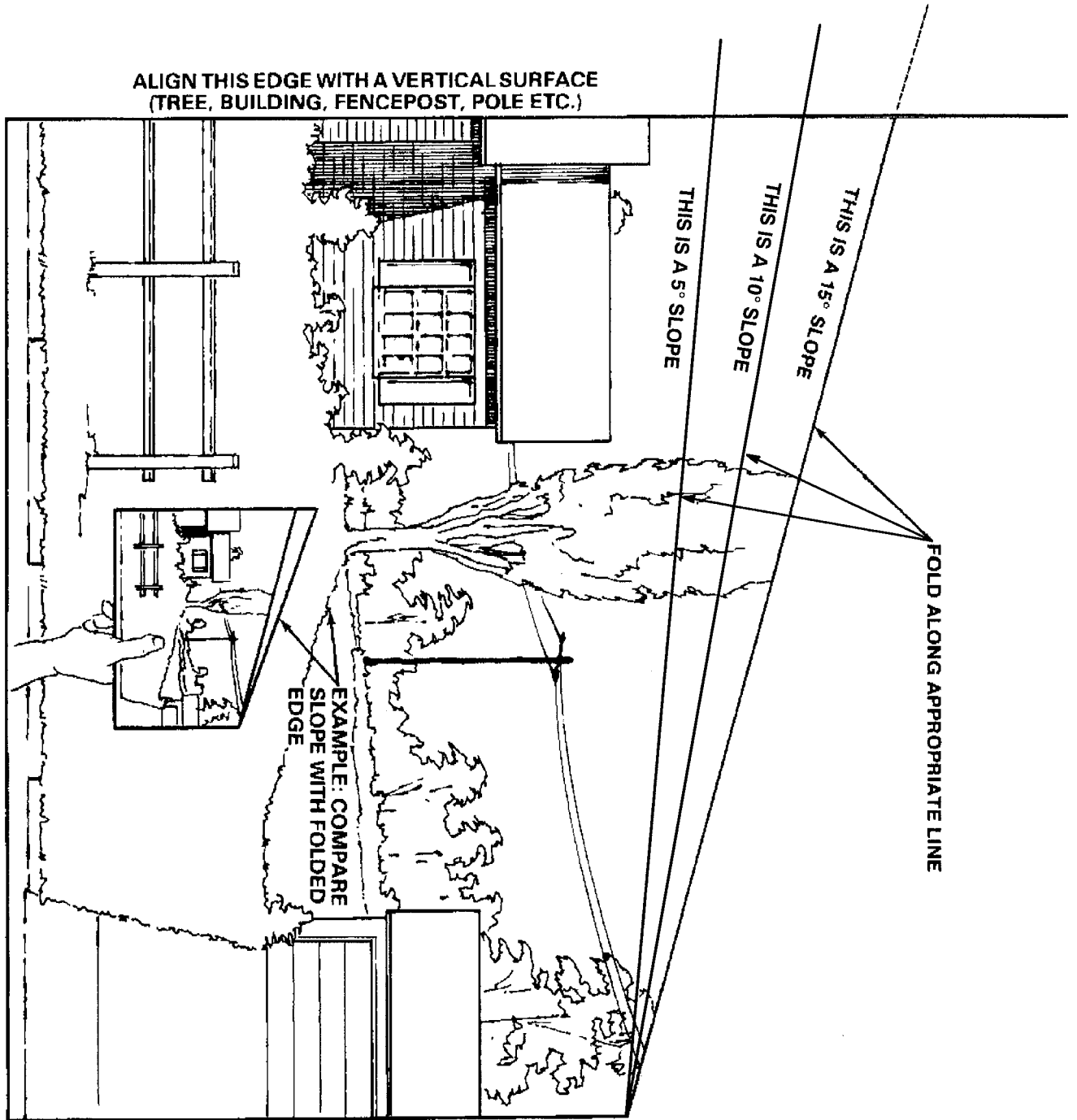

Safety and Instruction Decals



Safety decals and instructions are easily visible to the operator and are located near any area of potential danger. Replace any decal that is damaged or lost.

ON DASH ABOVE STEERING WHEEL (Part No. 92-9837)

⚠ DANGER

TO AVOID SERIOUS INJURY OR DEATH:

- READ AND UNDERSTAND THE OPERATOR'S MANUAL.
- KNOW LOCATION AND FUNCTION OF CONTROLS.
- NEVER USE WHEN UNDER THE INFLUENCE OF ALCOHOL OR DRUGS.
- USE SAFELY; MACHINE IS NOT A TOY; NEVER LET CHILDREN OPERATE.
- GO UP AND DOWN SLOPES, NOT ACROSS.
- AVOID SHARP OR SUDDEN TURNS AND SLIPPERY OR STEEP AREAS.
- IF MACHINE STOPS GOING UPHILL, STOP BLADE AND BACK SLOWLY DOWN.
- NEVER MOW WHEN CHILDREN OR OTHERS ARE IN THE MOWING AREA.
- NEVER CARRY CHILDREN OR OTHER PASSENGERS.
- LOOK DOWN AND BEHIND BEFORE AND WHILE BACKING UP.
- KEEP SAFETY DEVICES IN PLACE AND WORKING; CHECK BEFORE EACH USE.
- SAFETY INTERLOCKS CAN FAIL; NEVER ASSUME BLADE IS STOPPED.
- STOP ENGINE, SET PARKING BRAKE AND REMOVE KEY IF LEAVING MACHINE.
- REMOVE OBJECTS THAT COULD BE THROWN BY THE BLADE.

NEVER MOW UPHILL OVER 10°

NEVER MOW DOWNHILL OVER 15°

ON RIGHT SIDE OF FRAME PLATE (Part No. 111534)

RANGE SELECTOR

← LOW HIGH →

GEAR SHIFT

ON LEFT SIDE OF FRAME PLATE (Part No. 111510)

PARKING BRAKE

TO ENGAGE:
DEPRESS BRAKE
PEDAL AND PULL
LEVER.

TO DISENGAGE:
DEPRESS BRAKE
PEDAL.

111510

ON FRAME PLATE UNDER STEERING WHEEL (Part No. 92-8946)

⚠ DANGER

**• ROTATING BLADES
CAN CUT OFF ARMS
AND LEGS.**

**• NEVER MOW WHEN
CHILDREN ARE NEAR.**

**• NEVER CARRY RIDERS;
THEY FALL OFF.**

92-8946

UNDER CHOKE ON HOODSTAND (Part No. 112168)

↑

DOWN

LIFT

UP

↓

UNDER THROTTLE ON HOODSTAND (Part No. 111960)

↑

ENGAGE

PTO

CLUTCH

DISENGAGE

↓

UNDER HOOD (Part No. 88-3200)

OWNER'S NAME: _____
The numbers below identify your make tractor and parts by make and model number. Please refer to the back of this card for more information.

REMOVE "PULL TO CHOOSE" LABEL FROM THE BACK OF THIS CARD TO PREVENT THEFT.

PLEASE KEEP THIS CARD WITH YOUR TRACTOR.

OWNER'S NAME: _____
TRACTOR MAKE: _____
TRACTOR MODEL: _____
TRACTOR TYPE: _____
TRACTOR YEAR: _____

MODEL & ATTACHMENT IDENTIFICATION NUMBERS

Model: _____
Tractor: _____
Engine: _____
Mower: _____
Other: _____

MAINTENANCE CHART

MAINTENANCE ITEM	SERVICE INTERVAL
CHECK SAFETY INTERLOCK SYSTEM	BEFORE EACH USE
CHECK ENGINE OIL LEVEL	BEFORE EACH USE
CHECK BATTERY WATER LEVEL	BEFORE EACH USE
CHECK AUTOMATIC TRANS. OIL LEVEL (H)	BEFORE EACH USE
GENERAL EQUIPMENT CONDITION	BEFORE EACH USE
CLEAN ENGINE CHAFF SCREEN	AFTER EACH USE
LUBRICATE DRIVE CHAINS	EVERY 8 HOURS
CHECK TIRE PRESSURE	EVERY 24 HOURS
CHECK SAFETY MOUNTING PLACES & LIGHTS	EVERY 24 HOURS
CHECK & SPEED TRANS. OIL LEVEL	EVERY 24 HOURS
CLEAN AIR FILTER PRECLEANER (S)	EVERY 24 HOURS
LUBRICATE CHASSIS DRIVE WHEELS	EVERY 24 HOURS
LUBRICATE MOWER DRIVE WHEELS	EVERY 24 HOURS
CHANGE ENGINE OIL & OIL FILTER	EVERY 25 HOURS
CHANGE ENGINE OIL, CHANGE AUTO POWER FLUID	EVERY 25 HOURS
LUBRICATE MOWER SPINNERS	EVERY 50 HOURS
CHECK ENGINE ADJUSTMENTS	EVERY 80 HOURS
CLEAN ENGINE EXTERIOR & COOLING FINS	EVERY 80 HOURS
CHANGE AUTOMATIC TRANS. OIL, OIL TEMP.	EVERY 100 HRS. ONCE A YEAR
REPLACE SPARK PLUGS	EVERY 100 HOURS
REPLACE ENGINE OIL FILTER	EVERY 100 HOURS
REPLACE AIR FILTER	EVERY 100 HOURS
BROGS & STRATTON	EVERY 100-200 HOURS
CRANK TORQ POWER PLUS	EVERY 200 HOURS
MOULDER	EVERY 100 HRS AS NEEDED
REPLACE IN-LINE FUEL FILTER	ONCE A YEAR

NOTE:

- See operator's manual for detailed instructions.
- Increase frequency of service under extremely dirty duty conditions.
- See engine operator's manual for integrated maintenance items, such as TAPPET ADJUSTMENT and CYLINDER HEAD CLEANING.

(1) Models with separate transmission & separate oil reservoir - check transmission oil level before each use. Check reservoir oil level every 25 hours.
(2) Models with an oil sensor - service position when indicator light illuminates; replace air filter when service interval becomes noticeable by shorter. 88-3200

ON RIGHT INSIDE HOODSTAND NEXT TO BATTERY (Part No. 111926)

**DO NOT OPERATE WITH
BATTERY DISCONNECTED.
DAMAGE TO ELECTRICAL
SYSTEM WILL RESULT.**

UNDER STEERING WHEEL ON HOODSTAND (Part No. 79-5810)

PULL TO CHOKE

OPERATE

THROTTLE

IDLE

UNDER STEERING WHEEL ON HOODSTAND (Part No. 79-2470)

ON

OFF

LIGHTS

OFF

ON

IGNITION

Gasoline and Oil

Recommended Gasoline

Use UNLEADED Regular Gasoline suitable for automotive use (85 pump octane minimum). Leaded regular gasoline may be used if unleaded regular is not available.

IMPORTANT: Never use methanol, gasoline containing methanol, or gasohol containing more than 10% ethanol because the fuel system could be damaged. Do not mix oil with gasoline.

DANGER

POTENTIAL HAZARD

- In certain conditions gasoline is extremely flammable and highly explosive.

WHAT CAN HAPPEN

- A fire or explosion from gasoline can burn you, others, and cause property damage.

HOW TO AVOID THE HAZARD

- Use a funnel and fill the fuel tank outdoors, in an open area, when the engine is cold. Wipe up any gasoline that spills.
- Do not fill the fuel tank completely full. Add gasoline to the fuel tank until the level is 1/4" to 1/2" (6 mm to 13 mm) below the bottom of the filler neck. This empty space in the tank allows gasoline to expand.
- Never smoke when handling gasoline, and stay away from an open flame or where gasoline fumes may be ignited by a spark.
- Store gasoline in an approved container and keep it out of the reach of children. Never buy more than a 30-day supply of gasoline.

Stabilizer/Conditioner

Add the correct amount of gas stabilizer/conditioner to the gas. Using a stabilizer/conditioner in the machine:

- Keeps gasoline fresh during storage
- Cleans the engine while it runs
- Eliminates gum-like buildup in the fuel system, which causes hard starting

IMPORTANT: Never use fuel additives containing methanol or ethanol.

Filling the Fuel Tank

1. Shut the engine off and raise the seat.
2. Clean around the fuel tank cap and remove the cap. Use a funnel and add unleaded regular gasoline to the fuel tank, until the level is 1/4 to 1/2 inch (6 mm to 13 mm) below the bottom of the filler neck. This space in the tank allows gasoline to expand. Do not fill the fuel tank completely full.
3. Install the fuel tank cap securely. Wipe up any gasoline that may have spilled.
4. Low fuel level is indicated on fuel gauge.

Check Engine Oil Level

Before you start the engine and use the machine, check the oil level in the engine crankcase; refer to Checking Oil Level, page 19.

Operation

Think Safety First

Please carefully read all the safety instructions on pages 2–8. Knowing this information could help you, your family, pets or bystanders avoid injury.

Controls

Become familiar with all the controls (Fig. 1) before you start the engine and operate the machine.

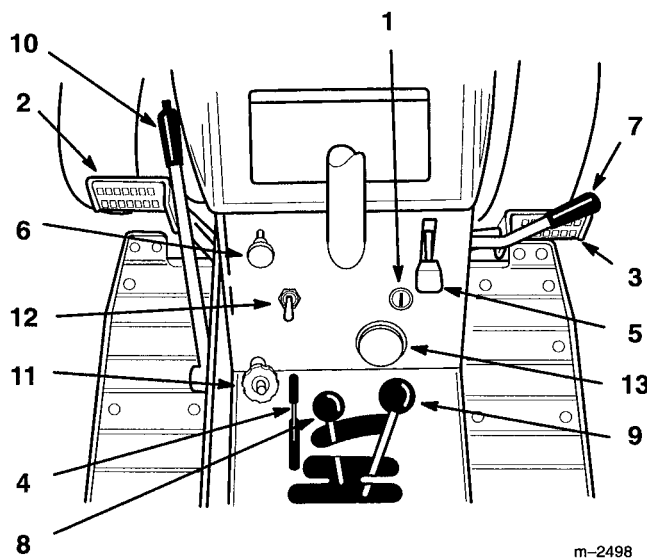

Figure 1

- | | |
|-------------------------|---------------------------|
| 1. Ignition switch | 8. Range selector |
| 2. Clutch pedal | 9. Gear shift |
| 3. Brake pedal | 10. Attachment lift lever |
| 4. Parking brake lever | 11. Dial-A-Height knob |
| 5. Throttle lever | 12. Light switch |
| 6. Choke lever | 13. Hour meter |
| 7. Power take off (PTO) | |

Parking Brake

Always set the parking brake when you stop the machine or leave it unattended.

While the ignition key is in the “RUN” position and the Parking Brake is engaged, the light, in the Indicator Module, will be lit.

Setting the Parking Brake

1. Push the brake pedal (Fig. 2) down and hold it in the depressed position.
2. Move the parking brake lever (Fig. 2) back and gradually take your foot off the brake pedal. The brake pedal should stay in the depressed (locked) position.

Releasing the Parking Brake

1. Push down on the brake pedal (Fig. 2). The parking brake lever should release.
2. Gradually release the brake pedal.

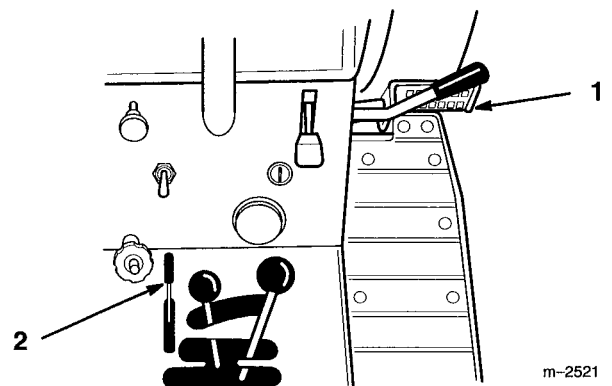

Figure 2

1. Brake pedal
2. Parking brake lever

Starting and Stopping the Engine

Starting

1. Sit down on the seat.
2. Set the parking brake; refer to Setting the Parking Brake, page 9.
3. Move the PTO (power take off) to disengage (Fig. 3).
4. Move the gear shift lever to “N” neutral; refer to Selecting Ground Speeds, page 13.
5. Move the choke lever to “ON” (Fig. 3).

Note: An engine that has been running and is warm may not require step 5.

6. Move throttle lever to “FAST” (Fig. 4).
7. Depress the clutch.
8. Turn the ignition key clockwise and hold it in the “START” position (Fig. 6). When the engine starts, release the key.

IMPORTANT: If the engine does not start after 30 seconds of continuous cranking, turn the ignition key to “OFF” and let the starter motor cool; refer to Troubleshooting, page 35.

9. After the engine starts, move the choke lever to “OFF” (Fig. 4). If the engine stalls or hesitates, move the choke lever back to “ON” for a few seconds. Then move the throttle lever to desired setting. Repeat this as required.

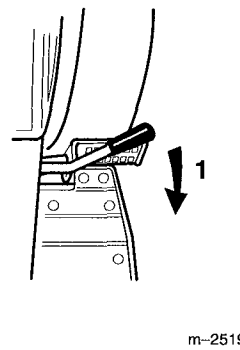

Figure 3

1. PTO—Disengaged

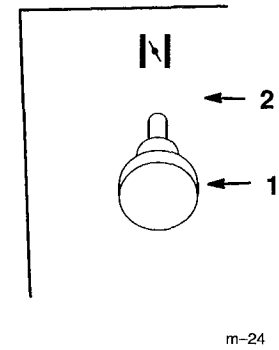

Figure 4

1. Choke—On
2. Choke—Off

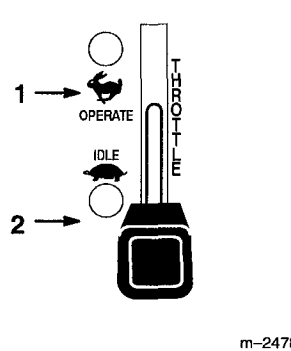

Figure 5

1. Fast
2. Slow

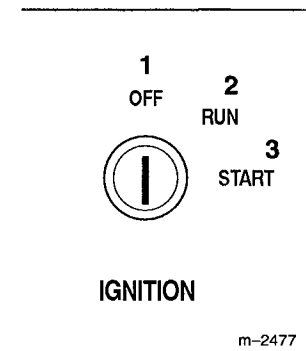

Figure 6

1. Off
2. Run
3. Start

Stopping

1. Move the throttle lever to “SLOW” (Fig. 5).
2. Turn the ignition key to “OFF” (Fig. 6).

Note: If the engine has been working hard or is hot, let it idle for a minute before turning the ignition key “OFF.” This helps cool the engine before it is stopped. In an emergency, the engine may be stopped by turning the ignition key to “OFF.”

Operating the Power Take Off (PTO)

The power take off (PTO) engages and disengages power to the clutch.

Engaging the Power Take Off (PTO)

1. Depress the clutch and brake pedals to stop the machine.
2. Push the power take off (PTO) lever forward to engage (Fig. 7).

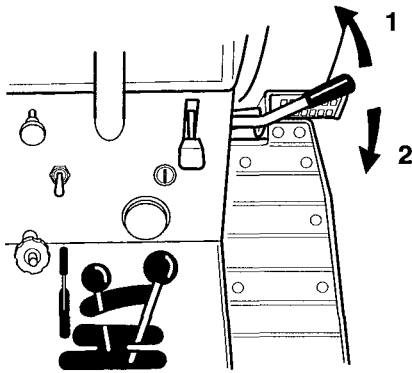

m-2521

Figure 7

1. Engaged

2. Disengaged

Disengaging the Power Take Off (PTO)

1. Depress the clutch and brake pedals to stop the machine.
2. Pull the power take off (PTO) lever back to disengage (Fig. 7).

The Safety Interlock System

Understanding the Safety Interlock System

The safety interlock system is designed to prevent the engine from starting unless:

- The clutch pedal is depressed
- The power take off (PTO) is “OFF”

The safety interlock system is designed to stop the engine if you rise from the seat when the power take off (PTO) is engaged.

Testing the Safety Interlock System

Test the safety interlock system before you use the machine each time. If the safety system does not operate as described below, have an Authorized Service Dealer repair the safety system immediately.

1. Depress the clutch. Move the power take off (PTO) to engaged. Now turn the ignition key to “START”; the engine should not crank.
2. Move the power take off (PTO) to disengaged and release the clutch. Now turn the ignition key to “START”; the engine should not crank.
3. Set the parking brake, depress the clutch and move the power take off (PTO) to disengaged. Now start the engine. While the engine is running, move the power take off (PTO) to engaged and rise slightly from the seat; the engine should stop.

Instruments

The gauges show conditions that need to be monitored during tractor operation. Read them to check operation immediately after starting the engine and regularly during use.

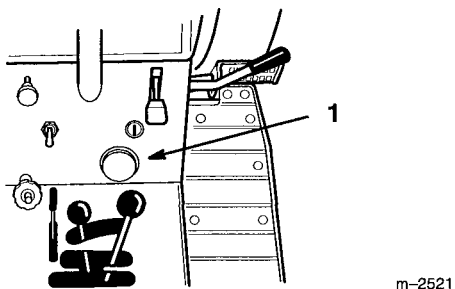

Figure 8

1. Hour meter

Hour Meter

The hour meter records the number of hours the engine has operated (Fig. 8). It is turned on when the ignition switch is in the "RUN" position. Use these times for scheduling regular maintenance.

Driving Forward or Backward

The throttle control regulates the engine speed as measured in rpm (revolutions per minute). Place the throttle control in the “FAST” position for best performance.

! CAUTION

POTENTIAL HAZARD

- If you release the clutch pedal too quickly when the ground speed selector is in gear, you could suddenly put the machine in motion.

WHAT CAN HAPPEN

- Sudden engagement of the machine’s drive system could cause you to lose control.

HOW TO AVOID THE HAZARD

- Always release the clutch pedal slowly when starting the machine in motion (forward or reverse).

To go forward or backward, depress the clutch and brake pedals. Move the range selector to the desired high–low location and select a forward or reverse gear. Release the brake pedal. As you slowly release the clutch pedal, the machine will begin to move. Steer the machine with the steering wheel.

IMPORTANT: Do not “Ride the Brakes,” or use brakes to slow ground speed when in gear. On hills shift to a lower gear for slower ground speed.

Selecting Ground Speeds

IMPORTANT: To avoid transmission damage, always depress the clutch and brake pedals before shifting gears or high–low range.

Always start the machine and change gears by depressing the clutch pedal (Fig. 9). In most conditions, the machine is powerful enough to move

out in any speed. If it will not move out in a selected speed (i.e., #5) due to a heavy load, use a lower speed (i.e., #2).

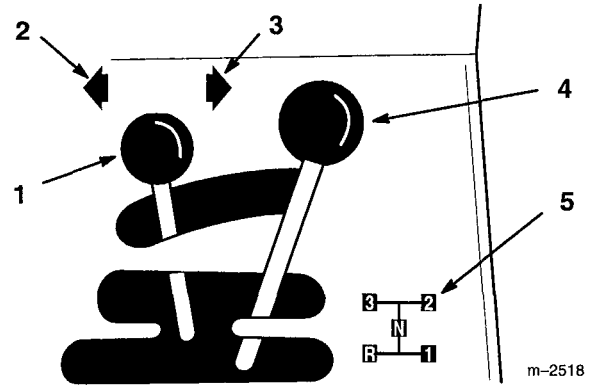

Figure 9

- | | |
|-------------------|---------------------------|
| 1. Range selector | 4. Ground speeds selector |
| 2. Low range | 5. Gear location 1-3, R |
| 3. High range | |

Stopping the Machine

To stop the machine, depress the clutch and brake pedals, disengage the power take off (PTO), and turn the ignition key to “OFF” to stop the engine. Also set the parking brake if you leave the machine unattended; refer to Setting the Parking Brake, page 9. Remember to remove the key from the ignition switch.

! CAUTION

POTENTIAL HAZARD

- Someone could move or attempt to operate the tractor while it is unattended.

WHAT CAN HAPPEN

- Children or bystanders may be injured if they use the tractor.

HOW TO AVOID THE HAZARD

- Always remove the ignition key and set the parking brake when leaving the machine unattended, even if just for a few minutes.

Attachment Lift Lever

The attachment lift lever (Fig. 10) is used to raise and lower various attachments.

Raising Attachments

1. Depress the clutch and brake pedals to stop the machine.
2. Pull attachment lift lever rearward until latch locks. In this position the lift will hold the attachment in the up, or raised position.

Lowering Attachments

1. Depress the clutch and brake pedals to stop the machine.
2. Pull attachment lift lever rearward, to release lift pressure, and push the button on top to release the latch. Move lift lever forward to lower attachment.

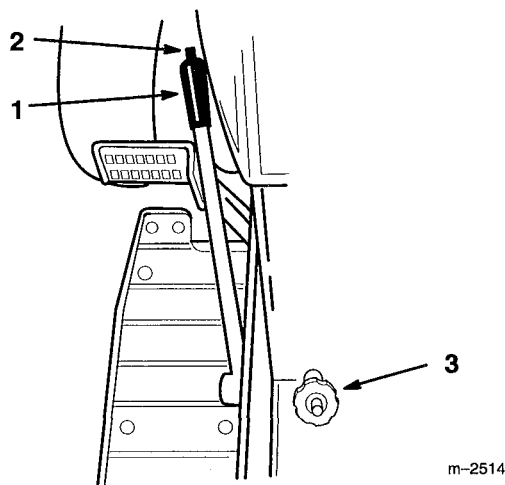

Figure 10

1. Lift lever
2. Button
3. Dial-A-Height

Adjusting Dial-A-Height

The Dial-A-Height control (Fig. 10) is used to limit the downward travel of the attachment. The knob is rotated to change the location of this stop, up or down.

1. Raise the attachment lift lever: Refer to Raising Attachments. In the raised position the Dial-A-Height knob (Fig. 10) can be rotated to change the stop location. Turn right to raise and left to lower the height of the attachment.

Positioning the Seat

The seat can move forward and backward. Position the seat where you have the best control of the machine and are most comfortable.

1. Raise the seat and loosen the adjustment knobs (Fig. 11).
2. Slide the seat to the desired position and tighten the knobs.

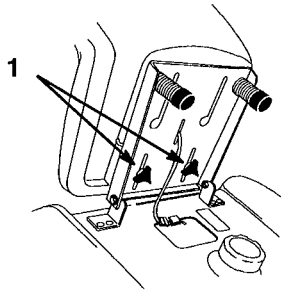

1202

Figure 11

1. Adjustment knob

Lights

The lights are turned on with a switch in the control panel (Fig. 12). The lights are on while the ignition switch is in the "Run" position even with the engine off. Remove the key when the machine is left unattended so lights can not be turned on discharging the battery.

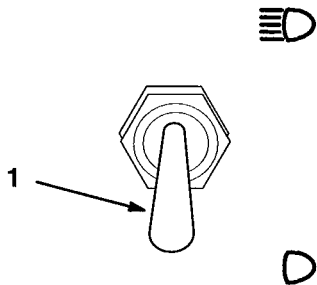

m-2516

Figure 12

1. Light switch

Installing PTO Belt

1. Park the machine on a level surface, disengage the power take off (PTO), set the parking brake, and turn the ignition key to "OFF" to stop the engine. Remove the key.
2. Remove the belt cover.
3. Remove hairpin cotters from trunnion and bottom of yoke (Fig. 13).
4. Unlatch and remove clevis pin that secures yoke assembly to clutch shaft. Pivot yoke out and forward to remove from clutch shaft and engagement plate (Fig. 13).
5. Place belt in pulley groove, going between clutch yoke and engagement plate (Fig. 13).

Note: Install belt in inside pulley groove for mowers and outside pulley groove for tiller and snowthrower.

6. Assemble yoke and engagement plate and attach clevis pin, trunnion and hairpin cotters to secure (Fig. 13).
7. Install the belt cover.

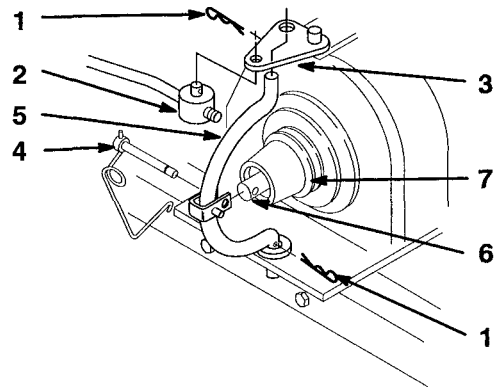

m-2691

Figure 13

- | | |
|---------------------|-----------------|
| 1. Hairpin cotter | 5. Yoke |
| 2. Trunnion | 6. Clutch shaft |
| 3. Engagement plate | 7. Belt groove |
| 4. Clevis pin | |

Maintenance

Service Interval Chart

Service Operation	Each Use	5 Hours	25 Hours	50 Hours	100 Hours	Storage Service	Spring Service
Oil—check level	X						
Oil—change*		Initial	X				
Safety System—check	X						X
Brake—check	X	X				X	X
Foam Air Cleaner—service*			X			X	
Paper Air Cleaner—replace*					X	X	
Spark Plug(s)—check					X	X	X
Chassis—grease*				X		X	
Belts—check for wear/cracks				X		X	
Gasoline—drain						X	
Engine—clean outside	X		X			X	
Chipped Surfaces—paint						X	
Battery—check electrolyte		X				X	X
Battery—charge, disconnect cables						X	
Fuel Filter—replace					X	X	
PTO Brake—adjust					X	X	
Tires—check pressure			X			X	X
Front Wheels—check toe-in						X	
Transaxle Fluid—check level	X					X	X

* More often in dusty, dirty conditions

CAUTION

POTENTIAL HAZARD

- If you leave the key in the ignition switch, someone could start the engine.

WHAT CAN HAPPEN

- Accidental starting of the engine could seriously injure you or other bystanders.

HOW TO AVOID THE HAZARD

- Remove the key from the ignition switch and pull the wire(s) off the spark plug(s) before you do any maintenance. Also push the wire(s) aside so it does not accidentally contact the spark plug(s).

Air Cleaner

Service Interval/Specification

Foam Element: Clean and re-oil after every 25 operating hours, or yearly, whichever occurs first.

Paper Element: Replace after every 100 operating hours or yearly, whichever occurs first.

Note: Service the air cleaner more frequently (every few hours) if operating conditions are extremely dusty or sandy.

Removing the Foam and Paper Elements

1. Disengage the power take off (PTO), set the parking brake, and turn the ignition key to "OFF" to stop the engine. Remove the key.
2. Open the hood.
3. Clean around the air cleaner to prevent dirt from getting into the engine and causing damage. Remove the wing nut and air cleaner cover (Fig. 14).

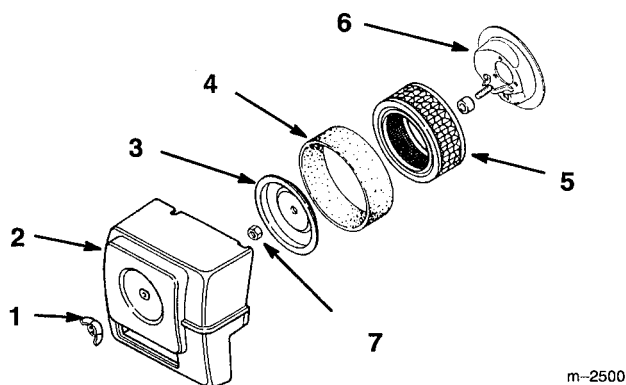

Figure 14

- | | |
|----------------------|---------------------|
| 1. Wing nut | 4. Foam element |
| 2. Air cleaner cover | 5. Paper element |
| 3. Cover | 6. Air cleaner base |

4. Unscrew the nut and remove the cover, foam element and paper element (Fig. 14).
5. Carefully slide the foam element off the paper element (Fig. 14).

Cleaning the Foam and Paper Elements

1. Foam Element
 - A. Wash the foam element in liquid soap and warm water. When the element is clean, rinse it thoroughly.
 - B. Dry the element by squeezing it in a clean cloth.
 - C. Put one or two ounces of oil on the element (Fig. 15). Squeeze the element to distribute the oil.

IMPORTANT: Replace the foam element if it is torn or worn.

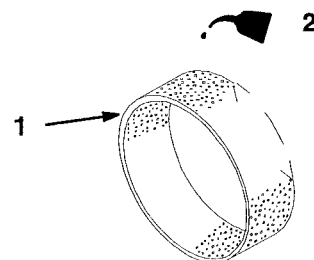

Figure 15

- | | |
|-----------------|--------|
| 1. Foam element | 2. Oil |
|-----------------|--------|

1213

m-2500

2. Paper Element

- A. Lightly tap the element on a flat surface to remove dust and dirt (Fig. 16).
- B. Inspect the element for tears, an oily film, and damage to the rubber seal.

IMPORTANT: Never clean the paper element with pressurized air or liquids, such as solvent, gas, or kerosene. Replace the paper element if it is damaged, defective, or cannot be cleaned thoroughly.

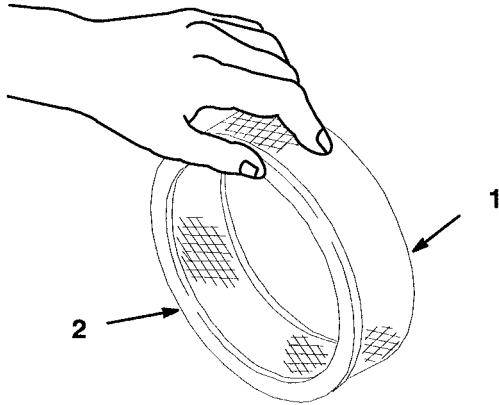

1213

Figure 16

- 1. Paper element
- 2. Rubber seal

3. Installing the Foam and Paper Elements

IMPORTANT: To prevent engine damage, always operate the engine with the complete foam and paper air cleaner assembly installed.

- 1. Carefully slide the foam element onto the paper air cleaner element (Fig. 14).
- 2. Place the air cleaner assembly into air cleaner base. Slide cover onto rod and secure with nut (Fig. 14).
- 3. Install the air cleaner cover and secure with wing nut (Fig. 14).
- 4. Close the hood.

Engine Oil

Service Interval/Specification

Change oil:

- After the first 5 operating hours.
- After every 25 operating hours.

Note: Change oil more frequently when operating conditions are extremely dusty or sandy.

Oil Type: Detergent oil (API service SF)

Crankcase Capacity: 2 quarts (1.9 l)

Viscosity: See table below

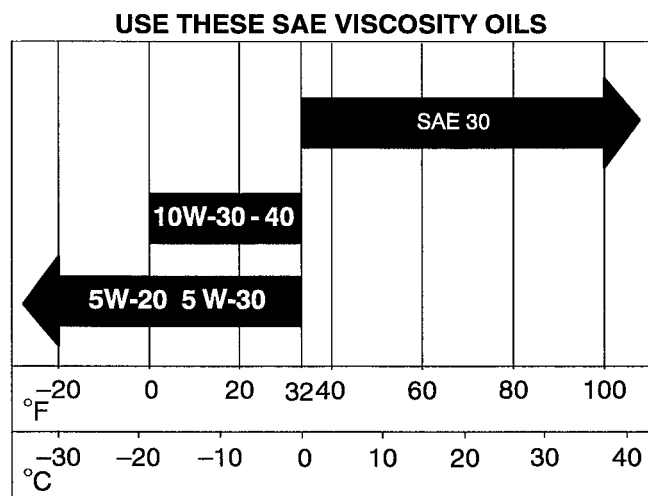

Checking Oil Level

1. Park the machine on a level surface, disengage the power take off (PTO), set the parking brake, and turn the ignition key to "OFF" to stop the engine. Remove the key.
2. Open the hood.
3. Clean around the oil dipstick (Fig. 17) so dirt cannot fall into the filler hole and damage the engine.
4. Pull the oil dipstick out and wipe the metal end clean (Fig. 17).
5. Push the oil dipstick fully into the filler tube (Fig. 17). Pull the dipstick out and look at the metal end. If oil level is low, slowly pour only enough oil into the filler tube to raise the level to the "FULL" mark.

IMPORTANT: Do not overfill the crankcase with oil because the engine may be damaged.

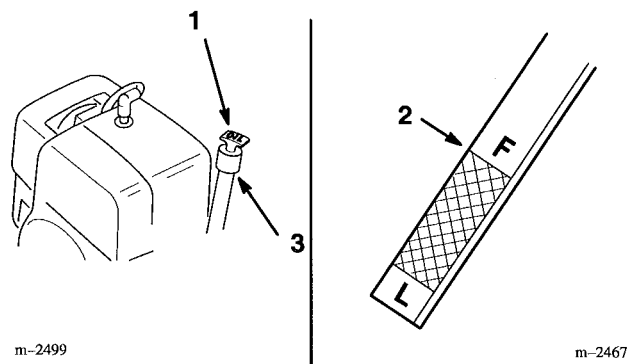

Figure 17

1. Oil dipstick
2. Metal end
3. Filler tube

Changing/Draining Oil

1. Start the engine and let it run five minutes. This warms the oil so it drains better.
2. Park the machine so that the drain side is slightly lower than the opposite side to assure the oil drains completely. Then disengage the power take off (PTO), set the parking brake, and turn the ignition key to "OFF" to stop the engine. Remove the key.
3. Open the hood.
4. Place a pan below the oil drain. Open the drain by removing the plug (Fig. 18).
5. When oil has drained completely, close the drain by installing the plug.

Note: Dispose of the used oil at a certified recycling center.

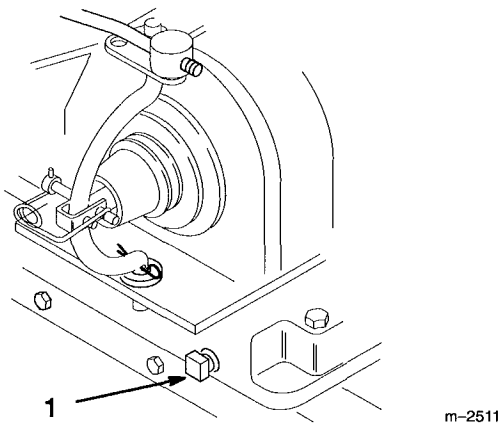

Figure 18

1. Oil drain plug
-

6. Slowly pour approximately 80% of the specified amount of oil into the filler tube (Fig. 17). Now check the oil level; refer to Checking Oil Level, page 19. Slowly add additional oil to bring to "FULL" mark on dipstick.

Spark Plug

Service Interval/Specification

Check the spark plug(s) after every 200 operating hours. Make sure the air gap between the center and side electrodes is correct before installing the spark plug. Use a spark plug wrench for removing and installing the spark plug(s) and a gapping tool/feeler gauge to check and adjust the air gap.

Type: Champion RH-10 (or equivalent)

Air Gap: 0.025" (.635 mm)

Removing the Spark Plug(s)

1. Disengage the power take off (PTO), set the parking brake, and turn the ignition key to "OFF" to stop the engine. Remove the key.
2. Open the hood.
3. Pull the wire(s) off the spark plug(s) (Fig. 19). Now clean around the spark plug(s) to prevent dirt from falling into the engine and potentially causing damage.
4. Remove the spark plug(s) and metal washer.

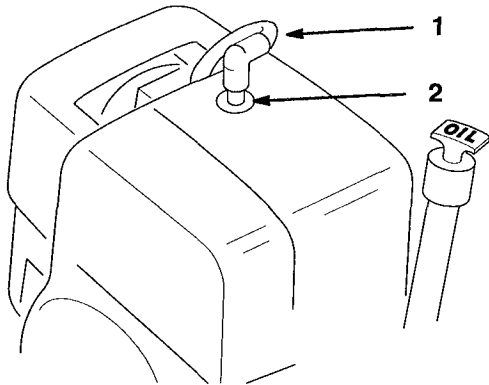

Figure 19

1. Spark plug wire

2. Spark plug

m-2499

Checking the Spark Plug

1. Look at the center of the spark plug(s) (Fig. 20). If you see light brown or gray on the insulator, the engine is operating properly. A black coating on the insulator usually means the air cleaner is dirty.

IMPORTANT: Never clean the spark plug(s). Always replace the spark plug(s) when it has: a black coating, worn electrodes, an oily film, or cracks.

2. Check the gap between the center and side electrodes (Fig. 20). Bend the side electrode (Fig. 20) if the gap is not correct.

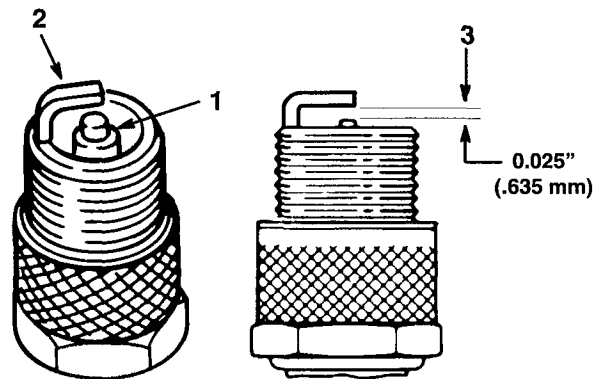

Figure 20

1. Center electrode insulator

2. Side electrode

3. Air gap (not to scale)

Installing the Spark Plug(s)

1. Install the spark plug(s) and metal washer. Make sure the air gap is set correctly.
2. Tighten the spark plug(s) to 20 ft-lb (27 Nm).
3. Push the wire(s) onto the spark plug(s) (Fig. 19).
4. Close the hood.

Greasing and Lubrication

Service Interval/Specification

Grease the machine after every 50 operating hours or yearly, whichever occurs first. Grease more frequently when operating conditions are extremely dusty or sandy.

Grease Type: General-purpose grease.

How to Grease

1. Disengage the power take off (PTO), set the parking brake, and turn the ignition key to "OFF" to stop the engine. Remove the key.
2. Clean the grease fittings with a rag. Make sure to scrape any paint off the front of the fitting(s).
3. Connect a grease gun to the fitting. Pump grease into the fittings until grease begins to ooze out of the bearings.
4. Wipe up any excess grease.

Where to Add Grease

1. Lubricate the front wheels, spindles and tie-rod ends until grease begins to ooze out of the bearings (Fig. 21).
2. Lubricate the front axle pivot (Fig. 21).

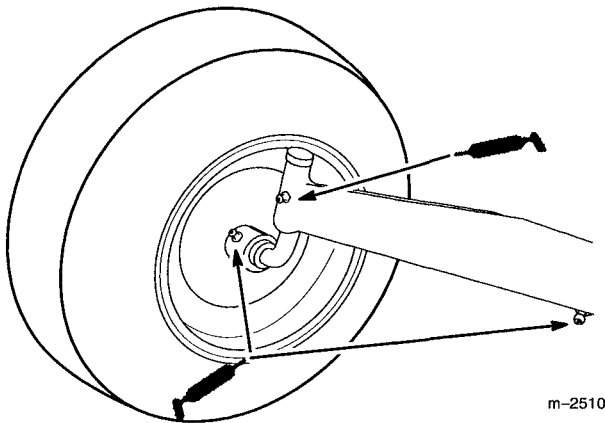

Figure 21

3. Lubricate the pedal(s) where it pivots on the mounting shaft, steering shaft and spread grease on steering sector teeth (Fig. 22).

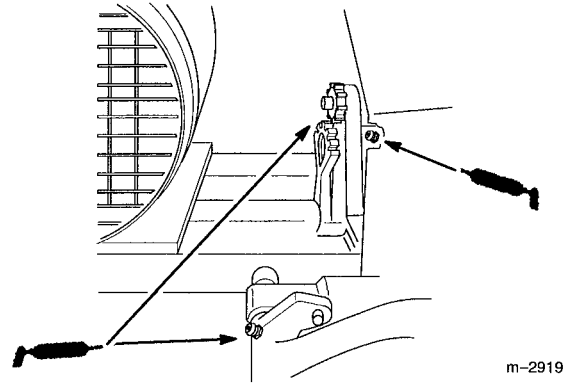

Figure 22

Tire Pressure

Service Interval/Specification

Maintain the air pressure in the front and rear tires as specified. Check the pressure at the valve stem after every 25 operating hours or monthly, whichever occurs first (Fig. 23). Check the tires when they are cold to get the most accurate pressure reading.

Pressure: 12 psi (.85 kPa) front and rear

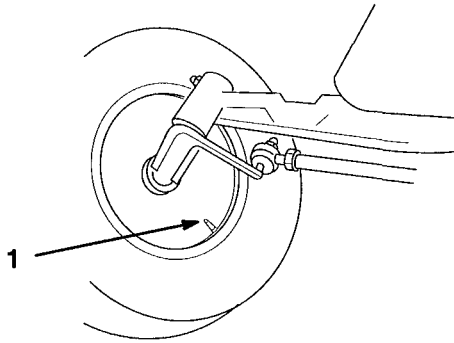

M-2488

Figure 23

1. Valve stem

Brake

Always set the parking brake when you stop the machine or leave it unattended. If the parking brake does not hold securely, an adjustment is required.

Checking the Brake

1. Park the machine on a level surface, disengage the power take off (PTO), set the parking brake, and turn the ignition key to "OFF" to stop the engine. Remove the key.
2. Place the gear shift in neutral. Rear wheels must lock and skid when you try to push the tractor forward. Adjustment is required if the wheels turn and do not lock; refer to Adjusting the Brake, page 24.
3. Release the parking brake and push the tractor. Wheels should rotate freely without brake drag.
4. If both conditions are met no adjustment is required.

Adjusting the Brake

The brake adjustment is behind the left side cover (Fig. 24). If the parking brake does not hold securely, an adjustment is required.

1. Check the brake before you adjust it; refer to Checking the Brake, page 24.
2. Set parking brake so latch is in second notch. To do this lift up on parking brake lever and slowly depress brake pedal and feel when latch is in second notch.
3. To adjust the brake tighten adjustment nut until rear wheels skid, then tighten an additional 1/2 turn (Fig. 24).
4. Check the brake operation again; refer to Checking the Brake, page 24.

IMPORTANT: With the parking brake released and the gear shift in neutral, the rear wheels must rotate freely when you push the tractor. If brake action and free wheel rotation cannot be achieved contact your service dealer immediately.

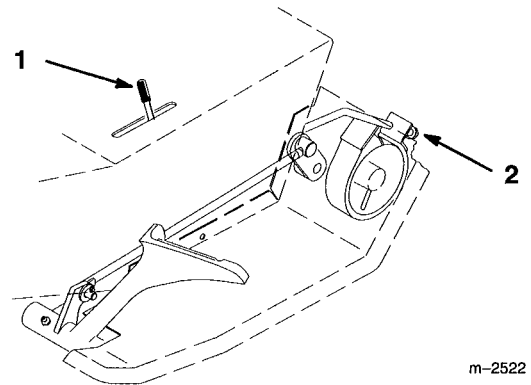

Figure 24

1. Parking brake lever
2. Adjustment nut

PTO (Power Take Off) Clutch and Brake

Service Interval/Specification

Check adjustment of PTO clutch and brake after every 100 operating hours or yearly, whichever occurs first. If attachment drive slippage or slow stopping is noticed adjust clutch and brake.

Adjusting PTO Clutch and Brake

1. Disengage the power take off (PTO), set the parking brake, and turn the ignition key to "OFF" to stop the engine. Remove the key.
2. Remove the belt cover.
3. To adjust clutch, remove hairpin cotter and thread trunnion onto rod one turn at a time until there is moderate resistance as the clutch engages and clutch slippage is eliminated (Fig. 25).
4. To adjust brake, engage PTO clutch and loosen (2) adjustment nuts (Fig. 25).
5. Place a 0.012 (0.3 mm) feeler gauge between brake pad and clutch pulley. Holding brake pad against feeler gauge tighten adjusting nuts. (Fig. 25).
6. Disengage PTO and check if brake pad engages properly to provide braking of PTO pulley.
7. Install the belt cover.

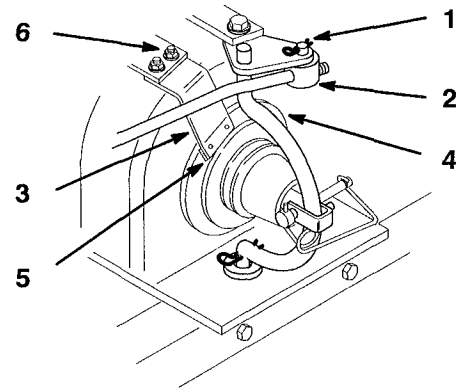

m-2480

Figure 25

- | | |
|-------------------|-------------------------------|
| 1. Hairpin cotter | 5. 0.012 (0.3mm) feeler gauge |
| 2. Trunnion | 6. Adjustment nut |
| 3. Brake pad | |
| 4. Pulley | |

Front Wheel Toe-In

Service Interval/Specification

Maintain toe-in of the front wheels as specified. If uneven tire wear, lawn scuffing or hard steering develop adjustment may be required. Check the toe-in after every 100 operating hours or yearly, whichever occurs first (Fig. 26).

Specification: 1/8–1/4 inch toe-in on front wheels.

Measuring Toe-in

1. Disengage the power take off (PTO), set the parking brake, and turn the ignition key to “OFF” to stop the engine. Remove the key.
2. Push front tires out, at front, to remove normal looseness in the linkage.
3. Measure, between the rims, at spindle level, in the front and rear of the wheels (Fig. 26).
4. The front measurement should be less than the rear, as specified.

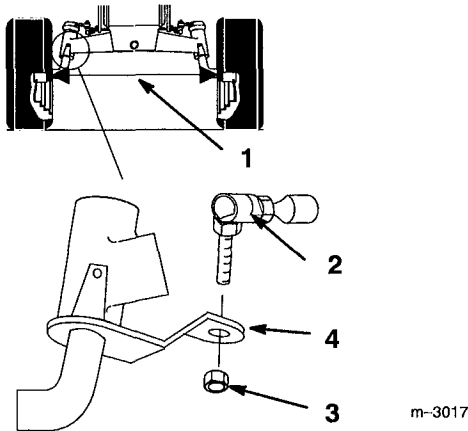

Figure 26

- | | |
|---------------------|-------------------|
| 1. Measure here | 3. Jam nut |
| 2. Ball joint flats | 4. Steering lever |

Adjusting Toe-In

1. Check the toe-in before you adjust it; refer to Measuring Toe-In, Page 26.
2. Remove ball joint from one steering lever (Fig. 26).
3. Loosen jam nut securing ball joint to steering rod. Rotate ball joint one turn, clockwise to decrease or counter clockwise to increase toe-in.
4. Install ball joint to steering lever and check the toe-in; refer to Measuring Toe-In, Page 26.

IMPORTANT: If more than one turn is required to meet specifications, alternate between left and right steering rods to maintain steering wheel alignment.

Fuel Tank

Draining The Fuel Tank

DANGER

POTENTIAL HAZARD

- In certain conditions gasoline is extremely flammable and highly explosive.

WHAT CAN HAPPEN

- A fire or explosion from gasoline can burn you, others, and cause property damage.

HOW TO AVOID THE HAZARD

- Drain gasoline from the fuel tank when the engine is cold. Do this outdoors in an open area. Wipe up any gasoline that spills.
- Never drain gasoline near an open flame or where gasoline fumes may be ignited by a spark.
- Never smoke a cigarette, cigar or pipe.

1. Park the machine on a level surface, to assure fuel tank drains completely. Then disengage the power take off (PTO), set the parking brake, and turn the ignition key to "OFF" to stop the engine. Remove the key.
2. Close fuel shut-off valve at fuel tank (Fig. 27).

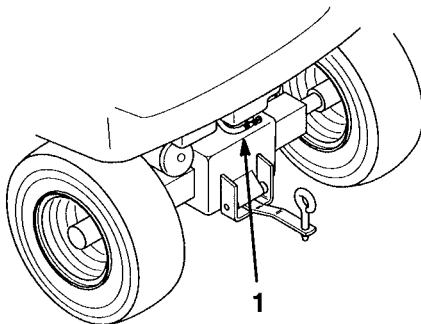

m-2383

Figure 27

1. Fuel shut-off valve

3. Loosen the hose clamp and slide it up the fuel line away from the fuel shut-off valve (Fig. 28).

4. Pull the fuel line off fuel shut-off valve (Fig. 28). Open fuel shut-off valve and allow gasoline to drain into a gas can or drain pan.

Note: Now is the best time to install a new fuel filter because the fuel tank is empty.

5. Install the fuel line onto the fuel shut-off valve. Slide the hose clamp close to the fuel shut-off valve to secure the fuel line (Fig. 28).

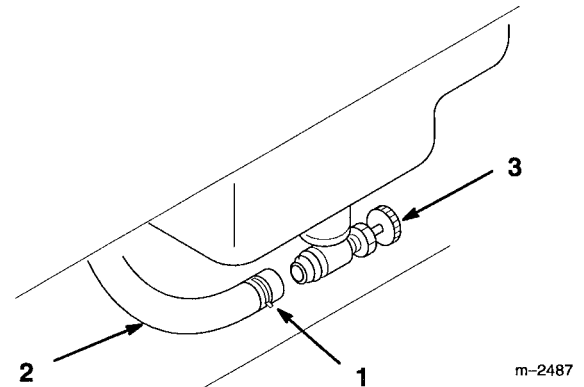

m-2487

Figure 28

1. Hose clamp
2. Fuel line
3. Fuel shut-off valve

Transaxle Fluid

Service Interval/Specification

Check fluid level before every use. Always keep the fluid level at the full level when the transaxle is cold.

Fluid Type: SAE 90 gear lube (API service QL-5)

Capacity: 2 quarts (1.9 l)

Checking Fluid Level

1. Park the machine on a level surface, disengage the power take off (PTO), set the parking brake, and turn the ignition key to "OFF" to stop the engine. Remove the key.
2. Tilt the seat up.
3. Clean around the transaxle dipstick (Fig. 29) so dirt cannot fall into the filler hole and damage the transaxle.

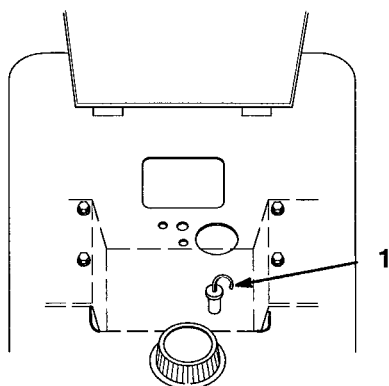

Figure 29

m-2512

1. Transaxle dipstick

4. Pull out the dipstick and wipe the metal end clean (Fig. 29).
5. Slide the dipstick fully into the filler tube (Fig. 17). Pull the dipstick out and look at the metal end. When transaxle is cold oil should be at the "Full" line on the dipstick (Fig. 29).
6. If oil level is low, slowly pour only enough oil into the filler tube to raise the level to the "FULL" mark.

IMPORTANT: Do not fill above the "Full" line as fluid may overflow when operating.

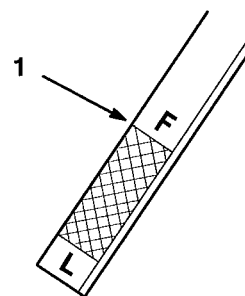

m-2467

Figure 30

1. Full cold level

Headlights

Removing the Bulb

1. Disengage the power take off (PTO), set the parking brake, and turn the ignition key to "OFF" to stop the engine. Remove the key.
2. Open the hood. Pull wire connectors off light terminals.
3. Remove screw securing retainer bracket (Fig. 31).
4. Lift and twist bulb out of pocket (Fig. 31).

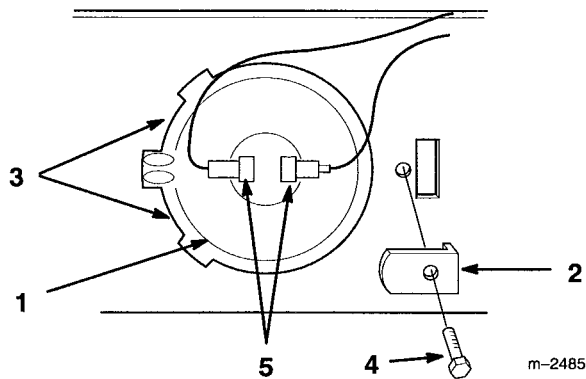

Figure 31

- | | |
|---------------------|--------------|
| 1. Bulb | 4. Screw |
| 2. Retainer bracket | 5. Terminals |
| 3. Tabs | |

Installing the Bulb

1. Locate index boss horizontal and twist bulb under tabs on left side of pocket (Fig. 31).
2. Hold bulb in socket with retainer bracket and secure with screw (Fig. 31).
3. Push wire connectors onto bulb terminals (Fig. 31).

Battery

Service Interval/Specification

Check the electrolyte level in the battery every five hours. Always keep the battery clean and fully charged. Use a paper towel to clean the battery case. If the battery terminals are corroded, clean them with a solution of four parts water and one part baking soda. Apply a light coating of grease to the battery terminals to prevent corrosion.

Voltage: 12 v, 210 Cold Cranking Amps

Removing the Battery

1. Disengage the power take off (PTO), set the parking brake, and turn the ignition key to "OFF" to stop the engine. Remove the key.
2. Open the hood to see the battery.
3. Disconnect the negative (black) ground cable from the battery post (Fig. 32).
4. Lift the rubber cover up on the positive cable. Disconnect the positive (red cover) cable from the battery post (Fig. 32).
5. Remove the battery hold down rods (Fig. 32). Lift battery from tractor

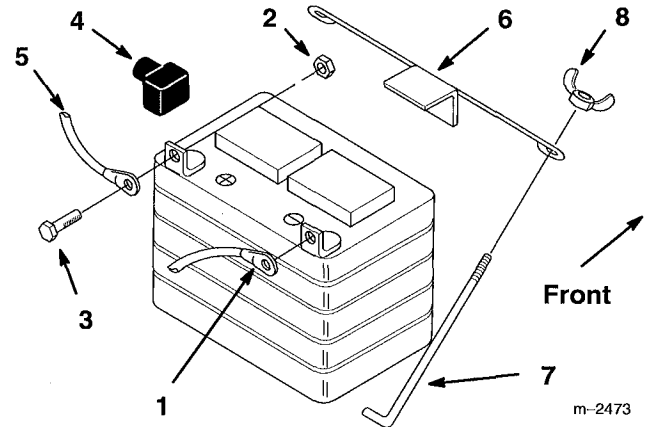

Figure 32

- | | |
|-----------------------|-------------------|
| 1. Negative cable | 5. Positive cable |
| 2. Locknut | 6. Battery clamp |
| 3. Bolt | 7. Hold down rod |
| 4. Rubber cover (red) | 8. Wing nut |

Installing the Battery

6. Install the battery into the chassis (Fig. 32).
7. Secure battery in chassis with hold down rods and wing nuts (Fig. 32).
8. Using the bolt and locknut, connect the positive (red cover) cable to the positive (+) battery post (Fig. 32). Slide the rubber cover over the battery post.
9. Using the bolt and locknut, connect the negative (black) cable to the negative (-) battery post (Fig. 32).

Checking Electrolyte Level

1. With the engine off, open the hood to see the battery.
2. Open covers to see into the cells. The electrolyte must be up to the lower part of the tube (Fig. 33). Do not allow the electrolyte to get below the plates. (Fig. 33).
3. If the electrolyte is low, add the required amount of distilled water; refer to Adding Water to the Battery, page 31.

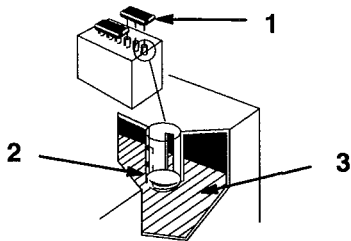

1262

Figure 33

1. Filler caps
2. Lower part of tube
3. Plates

Adding Water to the Battery

The best time to add distilled water to the battery is just before you operate the machine. This lets the water mix thoroughly with the electrolyte solution.

1. Clean the top of the battery with a paper towel.
2. Lift off the filler caps (Fig. 33).
3. Slowly pour distilled water into each battery cell until the level is up to the lower part of the tube (Fig. 33).

IMPORTANT: Do not overfill the battery because electrolyte (sulfuric acid) can cause severe corrosion and damage to the chassis.

4. Press the filler caps onto the battery.

Charging the Battery

IMPORTANT: Always keep the battery fully charged (1.260 specific gravity). This is especially important to prevent battery damage when the temperature is below 32°F (0°C).

1. Remove the battery from the chassis; refer to Removing the Battery, page 30.
2. Check the electrolyte level; refer to Checking Electrolyte Level, page 31, steps 2–3.
3. Remove the filler caps from the battery and connect a 3 to 4 amp battery charger to the battery posts. Charge the battery at a rate of 4 amperes or less for 4 hours (12 volts). Do not overcharge the battery. Install the filler caps after the battery is fully charged.

! WARNING

POTENTIAL HAZARD

- Charging the battery produces gasses.

WHAT CAN HAPPEN

- Battery gasses can explode.

HOW TO AVOID THE HAZARD

- Keep cigarettes, sparks and flames away from battery.

4. Install the battery in the chassis; refer to Installing the Battery, page 30.

Fuse

Service Interval/Specification

The electrical system is protected by fuses. It requires no maintenance, however, if a fuse blows check component/circuit for malfunction or short. To replace fuses pull up on the fuse (Fig. 34) to remove or replace it.

Fuse: Main F4-25 amp, blade-type
Lights F2-15 amp, blade-type

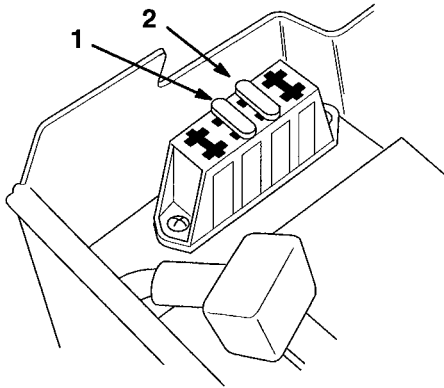

m-2459

Figure 34

1. Main-25 amp

2. Lights-15 amp

Wiring Diagram

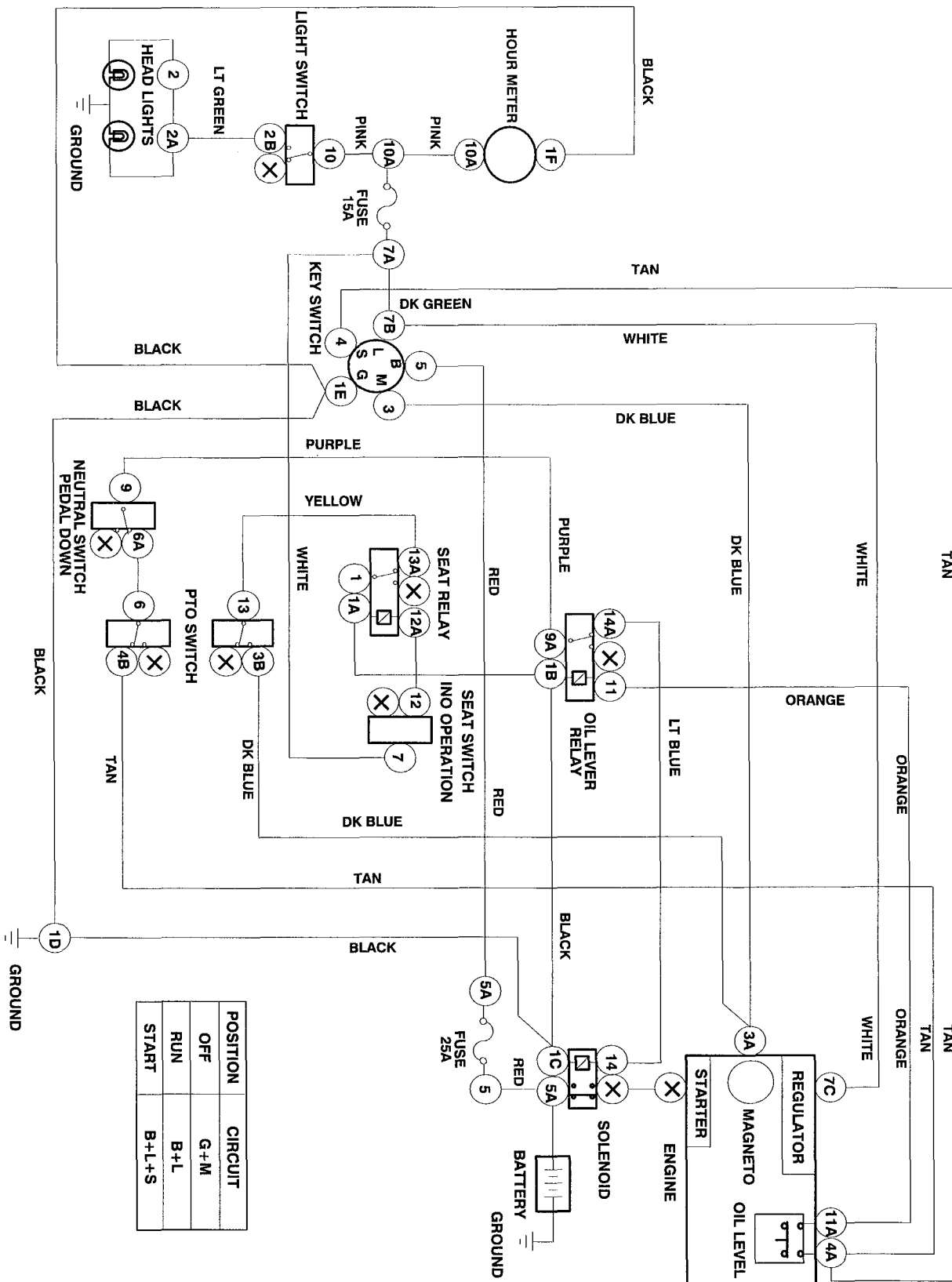

Cleaning and Storage

1. Disengage the power take off (PTO), set the parking brake, and turn the ignition key to “OFF” to stop the engine. Remove the key.
2. Remove grass clippings, dirt, and grime from the external parts of the entire machine, especially the engine. Clean dirt and chaff from the outside of the engine’s cylinder head fins and blower housing.

IMPORTANT: You can wash the machine with mild detergent and water. Do not pressure wash the machine. Avoid excessive use of water, especially near the control panel, lights, engine, and the battery.

3. Check the brake; refer to Brake, page 23.
4. Service the air cleaner; refer to Air Cleaner, page 17.
5. Grease the chassis; refer to Greasing and Lubrication, page 22.
6. Change the crankcase oil; refer to Engine Oil, page 19.
7. Remove the spark plug(s) and check its condition; refer to Spark Plug, page 21. With the spark plug(s) removed from the engine, pour two tablespoons of engine oil into the spark plug hole. Now use the electric starter to crank the engine and distribute the oil inside the cylinder. Install the spark plug(s) and tighten it to 15 ft–lb (20.4 Nm). Do not install the wire on the spark plug(s).
8. Remove the battery from the chassis, check the electrolyte level, and charge it fully; refer to Battery, page 30. Do not connect the battery cables to the battery posts during storage.

IMPORTANT: The battery must be fully charged to prevent it from freezing and being damaged at temperatures below 32°F (0°C). A fully charged battery maintains its charge for about 50 days at temperatures lower than

40°F (4°C). If the temperatures will be above 40°F (4°C), check the water level in the battery and charge it every 30 days.

9. Check the tire pressure; refer to Tire Pressure, page 23.
 10. During long-term storage, either drain gasoline from the fuel tank (step A) or add a fuel stabilizer/conditioner additive to a full tank of gasoline (step B).
 - A. Drain gasoline from the fuel tank; refer to Fuel Tank, page 27. After fuel is drained, start the engine and let it idle until all gasoline is consumed and the engine stops. This eliminates gum-like buildup in the fuel system, which causes hard starting. Try to start the engine two more times to assure that no gasoline is in the fuel system.
 - B. Add the correct amount of a fuel stabilizer/conditioner to a full tank of gasoline. Run engine for five minutes to distribute stabilizer through fuel system.
- Note:** Stabilizer/conditioners normally preserve gasoline for six to eight months.
11. Check and tighten all bolts, nuts, and screws. Repair or replace any part that is damaged or defective.
 12. Paint all scratched or bare metal surfaces. Paint is available from your Authorized Service Dealer.
 13. Store the machine in a clean, dry garage or storage area. Remove the key from the ignition switch and keep it in a memorable place. Cover the machine to protect it and keep it clean.

Troubleshooting

PROBLEM	POSSIBLE CAUSES	CORRECTIVE ACTION
Starter does not crank	<ol style="list-style-type: none"> 1. Blade control (PTO) is ENGAGED. 2. Parking brake is not on. 3. Operator is not seated. 4. Speed selector not in "N" neutral. 5. Battery is dead. 6. Electrical connections are corroded or loose. 7. Fuse is blown. 8. Relay or switch is defective. 	<ol style="list-style-type: none"> 1. Move blade control (PTO) to DISENGAGED. 2. Set parking brake. 3. Sit on the seat. 4. Move speed selector to "N" neutral. 5. Charge the battery. 6. Check electrical connections for good contact. 7. Replace fuse. 8. Contact Authorized Service Dealer.
Engine will not start, starts hard, or fails to keep running.	<ol style="list-style-type: none"> 1. Fuel tank is empty. 2. Choke is not ON. 3. Air cleaner is dirty. 4. Spark plug wire is loose or disconnected. 5. Spark plug is pitted, fouled, or gap is incorrect. 6. Dirt in fuel filter. 7. Dirt, water, or stale fuel is in fuel system. 	<ol style="list-style-type: none"> 1. Fill fuel tank with gasoline. 2. Move choke lever to ON. 3. Clean or replace air cleaner element. 4. Install wire on spark plug. 5. Install new, correctly gapped spark plug. 6. Replace fuel filter. 7. Contact Authorized Service Dealer.
Engine loses power.	<ol style="list-style-type: none"> 1. Engine load is excessive. 2. Air cleaner is dirty. 3. Oil level in crankcase is low. 4. Cooling fins and air passages under engine blower housing are plugged. 5. Spark plug is pitted, fouled, or gap is incorrect. 6. Vent hole in fuel cap is plugged. 7. Dirt in fuel filter. 8. Dirt, water, or stale fuel is in fuel system. 	<ol style="list-style-type: none"> 1. Shift into lower gear to reduce ground speed. 2. Clean air cleaner element. 3. Add oil to crankcase. 4. Remove obstruction from cooling fins and air passages. 5. Install new, correctly gapped spark plug. 6. Clean or replace the fuel cap. 7. Replace fuel filter. 8. Contact Authorized Service Dealer.

PROBLEM	POSSIBLE CAUSES	CORRECTIVE ACTION
Engine overheats.	<ol style="list-style-type: none"> 1. Engine load is excessive. 2. Oil level in crankcase is low. 3. Cooling fins and air passages under engine blower housing are plugged. 	<ol style="list-style-type: none"> 1. Shift into lower gear to reduce ground speed. 2. Add oil to crankcase. 3. Remove obstruction from cooling fins and air passages.
Abnormal vibration.	<ol style="list-style-type: none"> 1. Engine mounting bolts are loose. 2. Loose engine pulley, idler pulley, or blade pulley. 3. Engine pulley is damaged. 	<ol style="list-style-type: none"> 1. Tighten engine mounting bolts. 2. Tighten the appropriate pulley. 3. Contact Authorized Service Dealer.
Machine does not drive.	<ol style="list-style-type: none"> 1. Traction belt is worn, loose or broken. 2. Traction belt is off pulley. 3. Transmission does not shift. 	<ol style="list-style-type: none"> 1. Contact Authorized Service Dealer. 2. Contact Authorized Service Dealer. 3. Contact Authorized Service Dealer.



Consumer Riding Products

THE TORO TOTAL COVERAGE GUARANTEE

A Full Two-Year Warranty

(Limited Warranty For Commercial Use)

What Is Covered By This Express Warranty?

The Toro Company promises to repair any TORO Product used for normal residential purposes* if defective in materials or workmanship for a period of two years from the date of purchase with the following exceptions:

- Batteries are warranted for one year
- Twin cylinder engines used on 400 and 500 Series tractors are warranted for three years

This warranty covers the cost of parts and labor as well as transportation within a 15 mile radius of the servicing dealer.

What Products Are Covered By This Warranty?

This warranty applies to all consumer riding products and their attachments.

How About Commercial Use?

TORO Consumer Products used for commercial, institutional or rental use are covered by a limited warranty for the following time periods from the date of purchase:

Products	Warranty Period
• 300, 400 and 500 Series Lawn and Garden Tractors	
Chassis	1 year limited warranty
Single Cylinder Engine	2 year limited warranty
Twin Cylinder Engine	3 year limited warranty
• 260 Series Lawn and Garden Tractors, XL Lawn Tractors and Rear Engine Riders	90 day limited warranty

How Do You Get Warranty Service?

Should you feel your TORO Product contains a defect in material or workmanship, contact the dealer who sold you the product or any Authorized TORO Service Dealer or TORO Master Service Dealer. The Yellow Pages of your telephone directory is a good reference source. The dealer will either arrange service at his/her dealership or recommend another Authorized Service Dealer who may be more convenient. You may need proof of purchase (copy of registration card, sales receipt, etc.) for warranty validation.

If for any reason you are dissatisfied with the Service Dealer's analysis of the defect in materials or workmanship or if you need a referral to a TORO Service Dealer, please feel free to contact us at the following address:

Toro Customer Service Department
8111 Lyndale Avenue South
Bloomington, MN 55420-1196
612-888-8801
800-348-2424

What Must You Do To Keep The Warranty In Effect?

You must maintain your TORO Product by following the maintenance procedures described in the operator's manual. Such routine maintenance, whether performed by a dealer or by you, is at your expense.

What Does This Warranty Not Cover? and

How Does Your State Law Relate To This Warranty?

There is no other express warranty. This express warranty does not cover:

- Cost of regular maintenance service or parts, such as filters, fuel, lubricants, tune-up parts, blade sharpening, brake and clutch adjustments.
- Any product or part which has been altered or misused or required replacement or repair due to normal wear, accidents, or lack of proper maintenance.
- Repairs necessary due to improper fuel, contaminants in the fuel system, or failure to properly prepare the fuel system prior to any period of non-use over three months.
- Pickup and delivery charges for distances beyond a 15 mile radius from an Authorized TORO Service Dealer.

All repairs covered by this warranty must be performed by an Authorized TORO Service Dealer using Toro approved replacement parts.

Repair by an Authorized TORO Service Dealer is your sole remedy under this warranty.

The Toro Company is not liable for indirect, incidental or consequential damages in connection with the use of the TORO Products covered by this warranty, including any cost or expense of providing substitute equipment or service during reasonable periods of malfunction or non-use pending completion of repairs under this warranty. Some states do not allow exclusions of incidental or consequential damages, so the above exclusion may not apply to you.

This warranty gives you specific legal rights, and you may also have other rights which vary from state to state.

* Normal residential purposes means mowing the lawn on the same lot as your home. Use at more than one location is considered commercial use and the commercial use warranty would apply.

COUNTRIES OTHER THAN THE UNITED STATES OR CANADA

Customers who have purchased TORO Products exported from the United States or Canada should contact their TORO Distributor (Dealer) to obtain guarantee policies for your country, province, or state. If for any reason you are dissatisfied with your Distributor's service or have difficulty obtaining guarantee information, contact the TORO importer. If all other remedies fail, you may contact us at The Toro Company.