



Count on it.

SENTINEL FIELD CONTROLLER

Programming Guide



TORO SENTINEL® **A** **B** Alarm Hold Irrigation

09:46A FR W6 JUN 15
GPM : A013.3 E013.2
AMP: 0.4

Home/Back Manual Watering Scheduled Watering Diagnostics & Alarms Station Settings

Option Start Help Stop Satellite Settings

Table of Contents

Chapter 1: Sentinel Control Module		
1 I. Control Module Overview	19 Program Clear	32 Clear Sat. Alarms
2 Control Module Display	20 Rain Off Days	33 Clear Comm. Alarms
2 Front LEDs	20 Assigned Schedule	33 Clear Elec. Alarms
3 Controls	21 Water Window	34 Clear Flow Alarms
5 Ports	21 Continuous Run	34 Show Moisture Data
7 II. Overview & Navigation	22 Repeat Delay Time	35 IV. Station Settings
9 Icons Explained	22 Repeats	35 Plant Factor
Chapter 2: Basic Programming	23 Percent Scale	35 Station Days Off
10 I. Satellite Settings	23 Slot-Station-Time	36 Maximum Flows
10 Time & Day	Chapter 3: Advanced Programming	36 Expected Flows
11 ET	25 I. Manual Watering	37 Map Stations
11 Language	25 Manual	38 Station Type
12 Flow Processing	26 Start / Stop Program	39 Precipitation Rate
12 Flow Factors Meter 2	26 II. Stop Menu	40 V. Option Menu
13 Flow Factors Meter 1	26 Full Shutdown	40 Radio Test Relay Code
13 N/O Master	27 All Manuals Off	40 Port 0/Bk Function
14 Station Count	27 All Autos Off	41 Port 1/Ft Function
14 Unit Code	28 III. Alarms Menu	41 TCP/IP Settings
15 Day Change Hour	28 Show Alarms & Warnings	42 BL Decoder Assign
16 II. Scheduled Watering	28 UHF Radio Test	42 Prog Toro AC Decoder
17 Start Times	29 Output Test	43 AC 2-Wire Addendum
17 Prog ET Toggle	30 Local Output Test	45 Frequently Asked Questions
18 Clear Schedule	30 Keypad Test	46 Troubleshooting Guide
18 Schedule Length	31 Display Test	47 Warranty and
19 Run Days	31 Port 1/Front Test	Dedication to Quality
	32 Port 0/Back Test	47 FCC Statement

Chapter 1: Sentinel Control Module

I. Overview

The Sentinel Control Module is the heart and brains of the Sentinel system. This overview will discuss the LCD screen, the Control Knob, and the buttons.

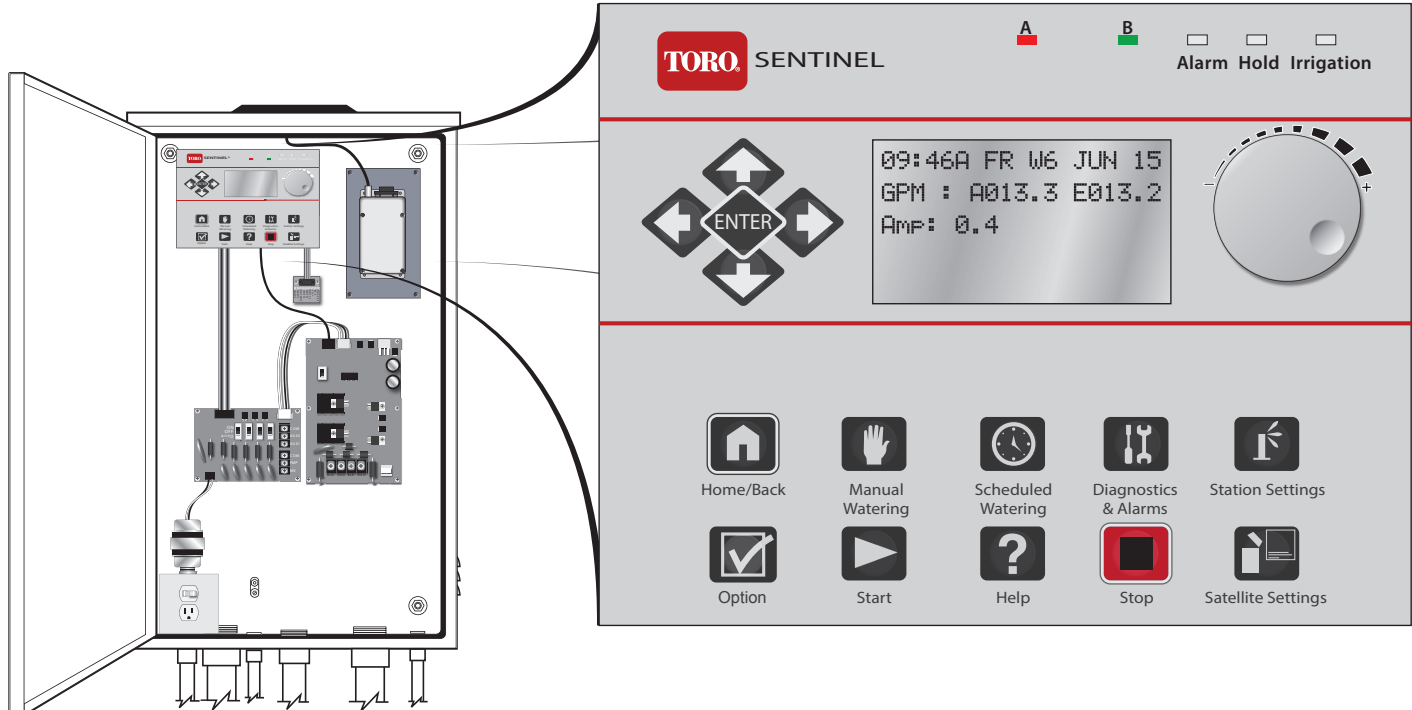

Control Module Display

The Sentinel Controller has a six-line LCD screen. When first powered on, the display will be in its standard mode.

1. Current time (HH:MM), day, week number of schedule (up to six weeks), and date.
2. If running, Actual flow (A#####) and Expected flow (E#####).
- **Actual Flow:** 5-digit numeric indicator of current flow through connected flow sensor.
- **Expected Flow:** 5-digit numeric indicator of expected flow based on current stations operating and their expected flows.
3. Current amperage draw

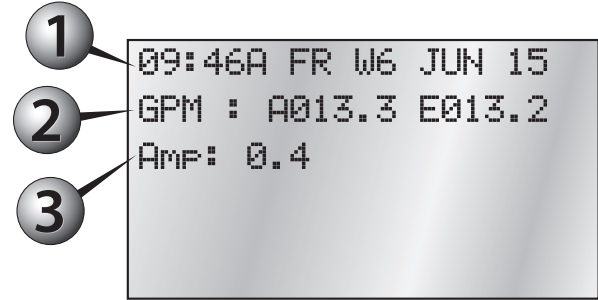

The Sentinel system takes roughly fifteen (15) seconds to display information up once plugged in. Please be patient.

Front LEDs

The front of the Sentinel Control Module has five LEDs to alert the user to particular conditions.









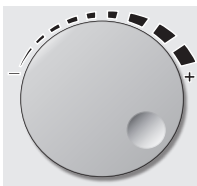



LED	Purpose
A	Flow 1 activity. Light turns off within a couple minutes of no flow input.
B	Flow 2 activity. Light turns off within a couple minutes of no flow input.
Alarm (Red)	Flashing light if any alarm; steady light if any warnings.
Hold (Amber)	A steady light indicates program or station days off.
Irrigation (Green)	Steady light on if an irrigation program is currently running.

Controls

There is one Control Knob and fifteen (15) buttons to operate the Sentinel Controller.

Control	Function
 <p data-bbox="305 281 495 303">Arrows and EN- TER</p>	<p data-bbox="548 175 836 196">LEFT / RIGHT Arrows:</p> <ol data-bbox="600 202 1209 260" style="list-style-type: none">1) Move through the different menus on the controller2) Within a menu line, move through the changeable fields. <p data-bbox="548 260 803 281">UP / DOWN Arrows:</p> <ol data-bbox="600 287 1088 345" style="list-style-type: none">1) Navigate through menu items2) Navigate from one submenu line to another. <p data-bbox="600 351 1063 377">Note: <i>Holding down an arrow button auto-repeats.</i></p> <p data-bbox="548 377 657 399">ENTER:</p> <p data-bbox="600 409 1112 430">Press to enter a selected menu or to save a setting.</p>
 <p data-bbox="321 547 479 569">Control Knob</p>	<p data-bbox="548 516 1510 569">Rotate the Knob to change the value of the field the cursor is on. Pressing the knob in is the same functionality as the ENTER key.</p>

Button	Function
 Home/Back	Returns the user to the previous screen (a “back” button) or to the Home screen.
 Manual Watering	Enter manual irrigation mode and manually start and stop programs.
 Scheduled Watering	Allows the user to program scheduled irrigation programs.
 Diagnostics & Alarms	Access the Diagnostics and Alarms menu system to identify and clear alarms.
 Station Settings	Access the Station Settings menu system.
 Option	Access the Option menu system.
 Start	Start station or program.
 Help	Accesses the Sentinel Help system (future feature).
 Stop	Enters the Stop menu, allowing full shutdowns and more.
 Satellite Settings	Accesses settings for the satellite, such as time, day, language, and much more.

Ports

Top Ports	Purpose
1. Serial Port 0 (9-pin connector)	Both top and bottom serial ports support communications devices, standard off-the-shelf serial cables, and are optically isolated.
2. Data Retrieval port (9-pin connector)	Works with existing Sentinel data retrieval cables and flow/ET/Rain pulse simulator devices. New cables will allow access to 1 additional flow and 1 additional alarm input. Both flow inputs support mixed mode use with flow, ET or Rain pulse devices.
3. Network RJ-45 port (option)	To connect to a network.
4. (10-pin connector)	UHF radio connection

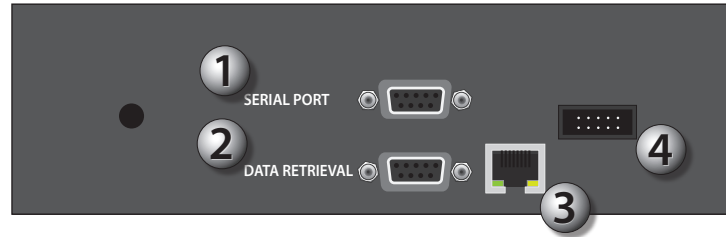

Bottom Ports	Purpose
1. Station output ports (15-pin connectors) (up to four)	These connect to the circuit boards in the Sentinel satellite, controlling up to 12-stations each for a maximum of 48 stations.
2. AC adapter and the red “power on” light	LED flashes if a program is running. The slower the flash, the slower the code is running
3. USB port	Allows connecting a thumb drive for “flashing” of the firmware.
4. 2-prong port	24 VAC connection
5. Serial Port 1 (9-pin connector)	Both top and bottom serial ports support communications devices, standard off the shelf serial cables, and are optically isolated.
6. Two fuse sockets with a red LED light next to each fuse socket	When the red LED is lit, indicates a blown fuse.

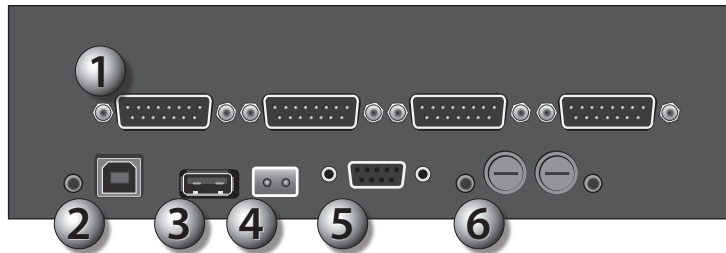

II. Programming Overview & Navigation



The Sentinel Controller is programmed by navigating through a Main Menu which includes seven submenus: **Manual Watering**, **Scheduled Watering**, **Diagnostics & Alarms**, **Station Settings**, **Help**, **Stop**, and **Satellite Settings**. Each of these submenu options has system configuration options. The menu structure is detailed below.

Menu	Setting	Function
Manual Watering	• Manual	• Turn individual stations ON or OFF for a specific time.
	• Start/Stop Program	• Start and stop programs.
Scheduled Watering	• Start Times	• Schedule the time for individual stations to activate, by program.
	• Prog ET Toggle	• Program individual programs (up to 16) to use ET data or not.
	• Clear Schedule	• Clear schedules of programs, one at a time.
	• Schedule Length	• Set the length of a schedule to run per schedule: six weeks or one year.
	• Run Days	• Specify which days per week a schedule should irrigate, by week, by schedule.
	• Program Clear	• Clear a particular program. <i>Note:</i> There is no confirmation before clearing.
	• Rain Off Days	• Enter “Rain Off” days by program, up to 255 days. What is this for?
	• Assigned Sched	• Assign schedules to programs or vica-versa.
	• Water Window	• Define “water windows” by program--watering only occurs between specified times.
	• Continuous Run	• Activate a program to run continuously.
	• Repeat Dly (Delay) Time	• Places a delay period, ranging from 0 to 255 minutes, between program repeats.
	• Repeats	• Enables the watering cycle to be repeated from 1 to 250 times per start time.
	• Percent Scale	• Adjust watering time by % of programmed time. Useful for seasonal adjustments.
• Slot-Stn-Time	• For a complete description of this command, see page 23.	
Diagnostics & Alarms	• Show Alarms & Warnings	• Show the cause of an “Alarm” flashing light.
	• Clear Sat. Alarms	• Clear any and all Satellite alarms.
	• Clear Comm. Alarms	• Clear any and all Communication alarms.
	• Clear Elec. Alarms	• Clear any and all Electronic alarms.
	• Clear Flow Alarms	• Clear any and all Flow alarms.
	• Show Moisture Data	• A moisture sensor must be installed for this command to work.

Menu	Setting	Function
Station Settings	<ul style="list-style-type: none"> Plant Factor Stn Days Off Maximum Flows Expected Flows Map Stations 	<ul style="list-style-type: none"> Assign a percentage factor to any zone for the type of plant material. Turn off individual stations for a specified number of days (up to 255). Set the maximum gallons per minute (GPM) for individual stations. Program the expected flow (GPM) for individual stations. Each station can be mapped, or associated with hardware other than the Sentinel controller output board. This setting relates to “Station Type” .
	<ul style="list-style-type: none"> Station Type Precip Rate 	<ul style="list-style-type: none"> Select the station type per station: LOCAL, UNIVERSAL, WIRELESS, TORO-2WD, BASELINE, or MC-48E. Set the precipitation rate (inches / hr) for each station.
Stop Menu	<ul style="list-style-type: none"> Full Shutdown All Manuals Off All Autos Off 	<ul style="list-style-type: none"> Shut down all stations immediately. Turn off all manually running stations. Turn off all programmed stations.
Satellite Settings	<ul style="list-style-type: none"> Time and Day ET Language Flow Processing Flow Factors Meter 2 Flow Factors Meter 1 N/O Master Station Count Unit Code Day Change Hour 	<ul style="list-style-type: none"> Set the time and day of the satellite. Set the maximum and default ET (evapotranspiration) levels. Specify the language the satellite uses: English, Spanish, or French. Set Flow Processing ON or OFF Aids in resolving Flow issues. See Chapter 2 explanation for this command. See Chapter 2 explanation for this command. Set the Master Circuit as normally closed or normally open. Specify the station count on the satellite, up to 204, in increments of 12. See Chapter 2 explanation for this command. See Chapter 2 explanation for this command.
Help	<ul style="list-style-type: none"> To be determined 	

Icons Explained

There are several icons used throughout the manual to portray certain functions.

Icon	Meaning
	Turn the Control Knob to change values in the currently highlighted field.
	Press the button / knob pictured under the finger.
	A line under characters on the LCD screen indicates a field that can be adjusted with the Control Knob.

Chapter 2: Basic Controller Programming

This section will provide the information on how to program the basic elements for automatic irrigation to occur. Remember to press ENTER or the Control Knob after making changes or changes will not be saved.

I. Satellite Settings



- Time and Day
- ET
- Language
- Flow Processing
- Flow Factors Meter 1
- Flow Factors Meter 2
- N/O Master
- Station Count
- Unit Code
- Day Change Hour

Time & Day (6 Fields to set: Hour, Minute, AM/PM, Month, Date, and Year)

When powering on the Sentinel system for the first time, it is necessary to set the time and day. Follow the steps below:

1

2 SATELLITE SETTINGS
Time & Day

3 Time & Day
04:34P JUN 18, 2012

4 ** SAVED! **
04:34P JUN 18, 2012

ET (4 Fields to set: Maximum and Default X whole and decimal values)

Default ET (evapotranspiration) is the minimum ET figure (in millimeters) that is used as the default ET regardless of the weather conditions or if data is missing from the ET gauge or weather station. ET can vary depending on the time of the season and weather. Generally, daily ET can be from 0mm to 13mm.

Maximum ET is the maximum ET value that can be accumulated between watering days. This value is the maximum value that a program will ever replace in a single day. Typically choose a value that is your maximum daily ET multiplied by the number of days between watering.

The diagram illustrates the steps to set ET (Maximum and Default) on a controller:

- 1** Press the **ET** button on the controller.
- 2** The screen displays **SATELLITE SETTINGS** with **ET** underlined. Press the **ENTER** button.
- 3** The screen displays **ET** with **Maximum:** 05.00 mm and **Default:** 02.00 mm. Use the arrow buttons to adjust the values. Press the **ENTER** button.
- 4** The screen displays **** SAVED! **** with **Maximum:** 05.00 mm and **Default:** 02.00 mm. Press the **ENTER** button to return to the main menu.

Language (1 Field to set)

Specify the language the Controller should use. English is the default language.

The diagram illustrates the steps to set Language on a controller:

- 1** Press the **Language** button on the controller.
- 2** The screen displays **SATELLITE SETTINGS** with **Language** underlined. Press the **ENTER** button.
- 3** The screen displays **Language** with **English** underlined. Press the **ENTER** button.

Flow Processing (1 Field to set)

Turn Flow Processing ON to monitor the flow of water to make sure flow is within limits determined by the irrigation zones running. If the flow is not within the limits, Sentinel will take user-defined action to identify and label problems.

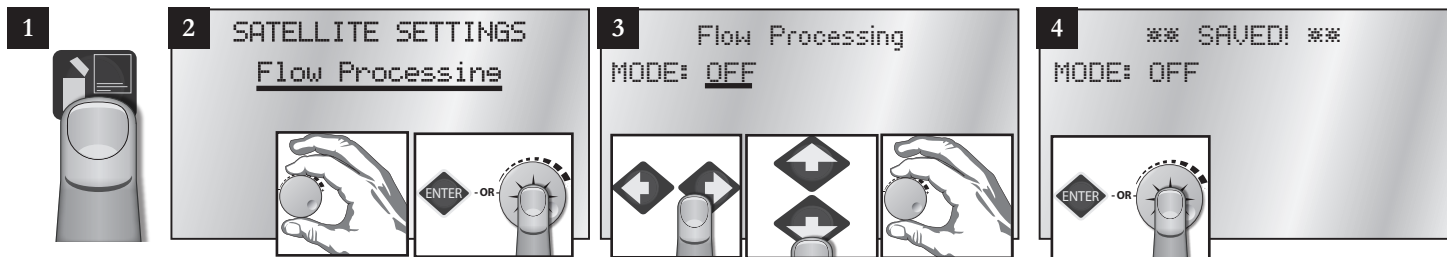

Note: For the controller to read and react to flow, a flow meter must be connected to the satellite sensor terminals. Do not turn on flow processing if it is not properly set up.

Flow Factors Meter 2 (4 Fields to set: K and Offset X whole and decimal values)

Flow factors are the K and offset for each meter, used to determine the flow rate in gallons per minute or liters per minute from the raw pulse rate of the meter. Flow factors are determined by the pipe size and type.

Enter/edit the K factor associated with the flow metering device being used. The K factor and Offset factor may be found in the Specification sheet for the flow meter.

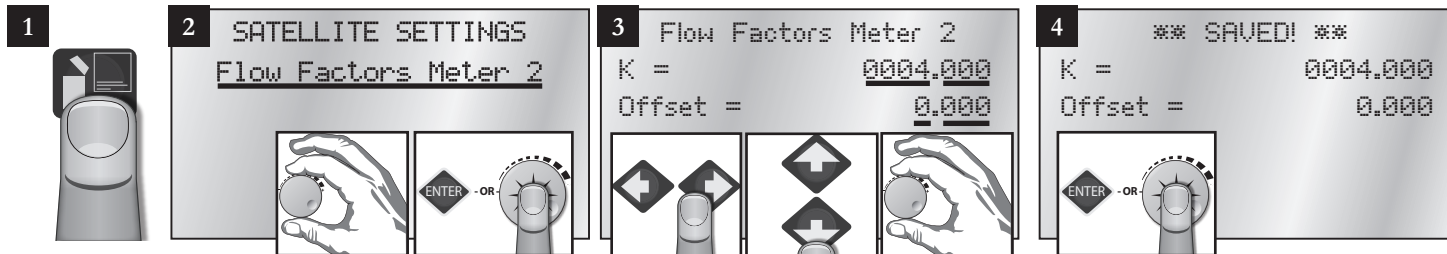

Flow Factors Meter 1 (4 Fields to set: K and Offset X whole and decimal values)

Flow factors are the K and offset for each meter, used to determine the flow rate in gallons per minute or liters per minute from the raw pulse rate of the meter. Flow factors are determined by the pipe size and type.

Enter/edit the K factor associated with the flow metering device being used. The K factor may be found in the specification sheet for the flow meter. The Offset factor may be found in the specification sheet for the flow meter.

1

2 SATELLITE SETTINGS
Flow Factors Meter 1

3 Flow Factors Meter 1
K = 0003.000
Offset = 1.000

4 ** SAVED! **
K = 0003.000
Offset = 1.000

N/O Master (1 Field to set)

Configure the master valve/pump start output for either normally OPEN or normally CLOSED operation.

1

2 SATELLITE SETTINGS
N/O Master

3 N/O Master
Normally: CLOSED

4 ** SAVED! **
Normally: CLOSED

Station Count (1 Field to set)

Use this menu to inform the controller the number of stations it has. The Sentinel controllers typically have station counts in 12-station increments (12, 24, 36, or 48).

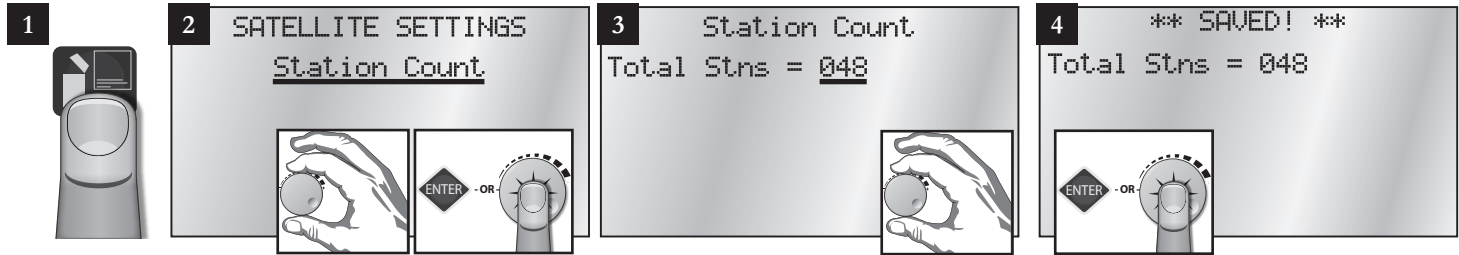

Unit Code (1 Field to set)

Every controller must have a three digit code assigned to it. This is known as the controller's address. It is possible to select any three digit code from 000 to 999. This is the identifier that is used when selecting an individual field controller with the hand held radio or from the central controller. If connecting via ethernet (and connecting more than one satellite), set unit codes between 1 and 255. Otherwise it is possible to set unit codes up to 999.

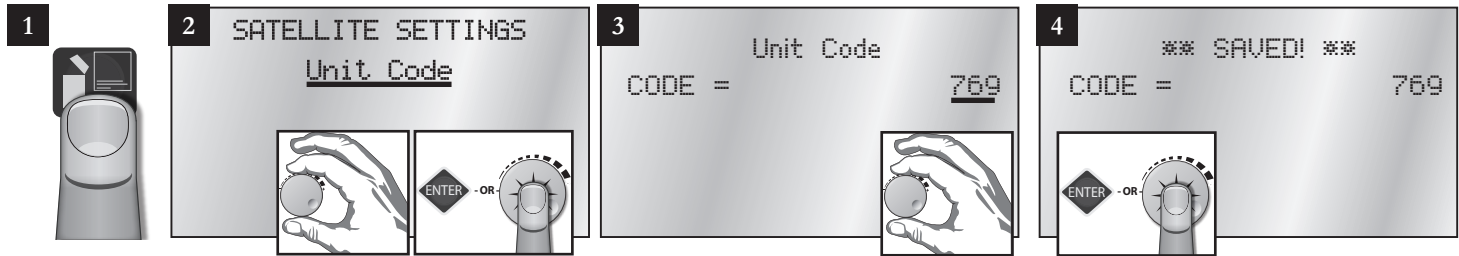

IMPORTANT: The unit code is required for Central Control operations. Even if most of the satellite programming will be from the central software, the Unit Code must be set.

Day Change Hour (1 Field to set)

It is possible to set the hour the controller advances to the next day. As an example, the day changes from Monday to Tuesday at midnight. It is possible to have the controller wait until 8 AM Tuesday before the controller changes the day label to Tuesday. This way, the controller will have until 8 AM Tuesday to finish all watering cycles from the Monday schedule.

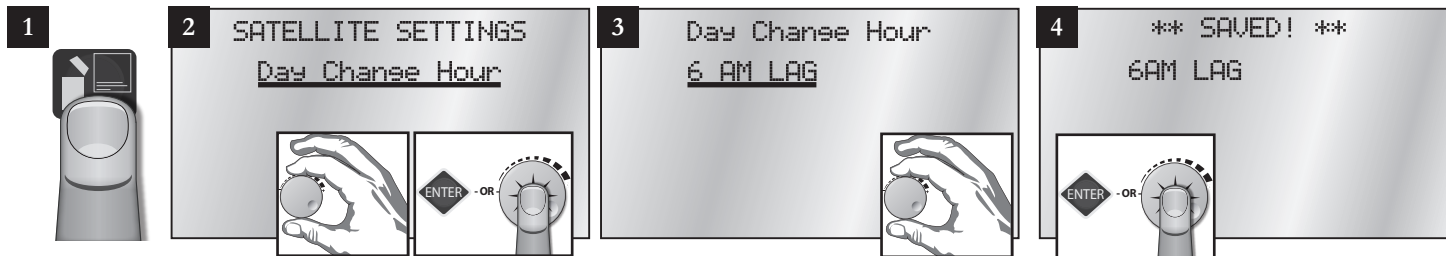

When you choose a day change hour it could lag (be after) or lead (be before) a normal midnight day change. For example, a day change hour of 11PM indicates the day changes at 11PM, but not what day.

An 11PM LEAD Day Change Hour means the current day changes one hour early.

An 11PM LAG Day Change Hour means the current day changes 23 hours late.

By indicating lead or lag along with the day change hour, Sentinel is able to determine the current irrigation day from the actual day and time.

The day of week displayed on the home screen with the time and month and date, is the *irrigation* day, not the actual day. They are only always the same if the Day Change Hour is set to midnight.

II. Scheduled Watering



- Start Times
- Prog ET Toggle
- Clear Schedule
- Schedule Length
- Run Days
- Program Clear
- Rain Off Days
- Assigned Sched
- Water Window
- Continuous Run
- Repeat Dly (Delay) Time
- Repeats
- Percent Scale
- Slot-Stn-Time

Schedule refers to the days of the week a program is set to run. Up to 16 unique watering day schedules can be defined in the Sentinel Controller. Each schedule has a number assignment from 1 to 16. In the controller display, schedules are indicated by “S” and its two-digit schedule number (01, 02,... 16). For example, Schedule 12 is shown as “S12.”

Each schedule can be programmed as either a six week schedule or a 365-day calendar. Toro recommends that all schedule programming through the faceplate be accomplished using 6-week schedules. Using a 365-day Calendar schedule requires the user to select the irrigation status for every day of the year. (All days are default OFF.)

A schedule may have any combination of watering days and may be assigned to any of the sixteen programs (covered in the next section, **Program Setup**). *You must assign a schedule to a program to activate it.* If using a 6 Week Schedule, the current Schedule Week was set in Time & Day as part of controller setup (example was set to W1). When the controller reaches the end of a six-week schedule (W6), the program loops back and starts again with Week 1 (W1).

Start Times (5 Fields to set: Program number, Station number, hour, minute, and AM/PM)

A Start Time initiates the automatic watering cycle. Each program can be assigned to start up eight times within a 24-hour period.

Note: *All start times must occur within the defined Water Window time frame. (See **Water Window**, below.)*

When multiple start times are used, they must be spaced far enough apart to enable the program irrigation cycle to be completed.

The controller offers eight start times per program. If more than eight start times are needed, see **Repeats** and **Continuous Run** below. Use this submenu item to display/edit any one of the eight start times.

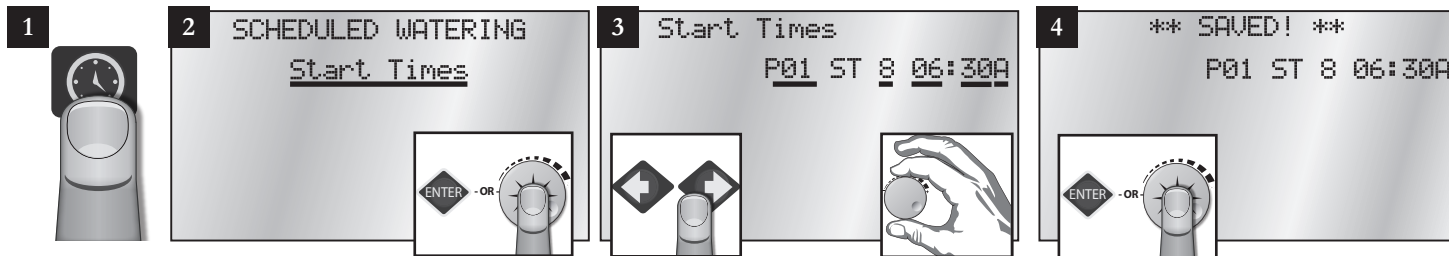

Prog ET Toggle (2 Fields to set: Program number, ET ON or OFF)

The controller is capable of running irrigation programs based on ET. When the ET functions are activated, the controller automatically adjusts program run times according to the ET data. A weather station or ET gauge needs to be connected to the sensor input terminals of the controller or at the central to provide ET data. Set to ON for any programs you wish to run based on ET values. For time-based watering, set to OFF. (Default is OFF)

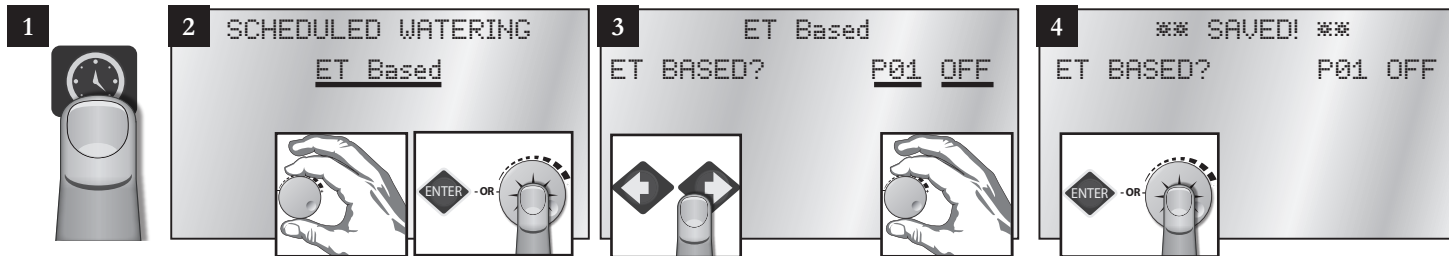

Clear/Set Schedule (2 Fields to set: Schedule number, Clear Schedule ON or OFF)

Clear any one schedule of all programming information.

1 

2 SCHEDULED WATERING
Clear/Set Schedule

3 Clear/Set Schedule
S02 SET TO: OFF

4 ** PLEASE WAIT **
S02 SET TO: OFF

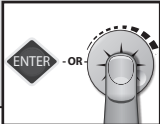
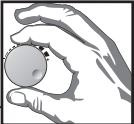
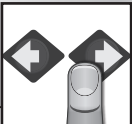
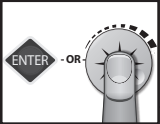
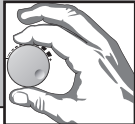

Schedule Length (2 Fields to set: Schedule number, Schedule length)





Select whether a Schedule (01... 16) is based on a 6-week calendar or a 365-day calendar.

1 

2 SCHEDULED WATERING
Schedule Length

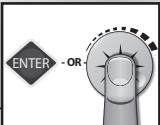
3 Schedule Length
S01 1 YEAR

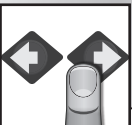
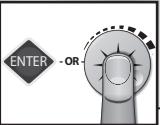
4 ** SAVED! **
S01 1 YEAR



IMPORTANT: *Changing the schedule length in either direction will clear the selected schedule.*

Run Days (9 Fields to set: Schedule number, week number, 7 Day-of-week toggles)

Configure the sixteen independent schedules, dictating what days will be water days or not.

For the **six-week schedule**, the default is water days are OFF. Use the Control Knob to toggle a non-watering day to a watering day. An “X” symbolizes a water day.

For a **year schedule**, the default is water days are ON. Use the Control Knob and arrow keys to select specific dates and turn them OFF.

1. A hand turns the control knob.

2. The display shows "SCHEDULED WATERING" and "Run Days". A hand presses the control knob, and the display shows "ENTER -OR-".

3. The display shows "Run Days" and "SMTWHFSa". A hand presses the left arrow key, and the display shows "S02 WK 2" and "X_X_X_X". A hand presses the control knob.

4. The display shows "** SAVED! **" and "SMTWHFSa". A hand presses the control knob, and the display shows "S02 WK 2" and "X_X_X_X".

Program Clear (2 Fields to set: Program number, Program Clear YES or NO)

Set all of the slot/station times within a selected program to zero. This function is helpful when clearing all 16 programs. Manually clearing station times in all 16 programs would otherwise be very time consuming.

1. A hand turns the control knob.

2. The display shows "SCHEDULED WATERING" and "Program Clear". A hand presses the control knob, and the display shows "ENTER -OR-".

3. The display shows "Program Clear" and "Clear? P01". A hand presses the left arrow key, and the display shows "YES". A hand presses the control knob.

4. The display shows "* PROG CLEARED *" and "Clear? P01". A hand presses the control knob, and the display shows "YES".

Rain Off Days (2 Fields to set: Program number, number of "off" days)

Disable programs for the number of days specified (typically in the event of rain). The Hold LED will be on during Rain Off Days. The days will automatically decrement each day at the Day Change Hour until Rain Off Days is zero. The station will then resume normal operation.

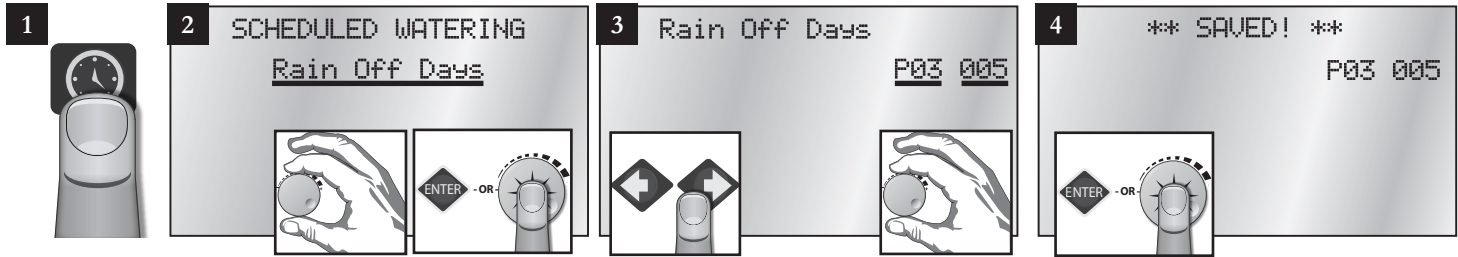

Assigned Schedule (2 Fields to set: Schedule number, Schedule length)

Up to 16 unique watering day schedules can be defined in the controller. For identification, each schedule has a number assignment ranging from 1–16. Each program must be assigned a schedule in order to run.

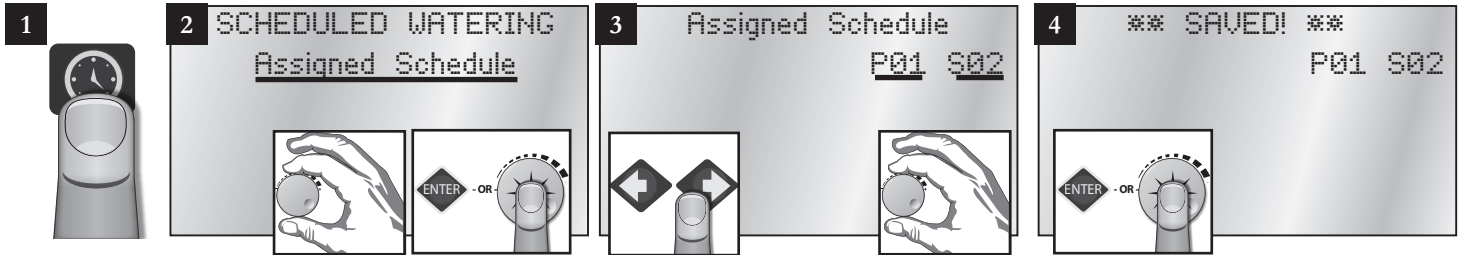

In Step 3 above, program 1 is being assigned to schedule 2.

Water Window (7 Fields to set: Program number, "FROM" hour, minute, AM/PM, "TO" hour, minute, AM/PM)

The Water Window is the period of time in a 24-hour day that automatic watering can occur. Selecting a FROM and TO time defines the Water Window start time and end time. A program that is running at the end of the Water Window is terminated immediately. Use Water Windows to set up continuous run start and stops automatically.

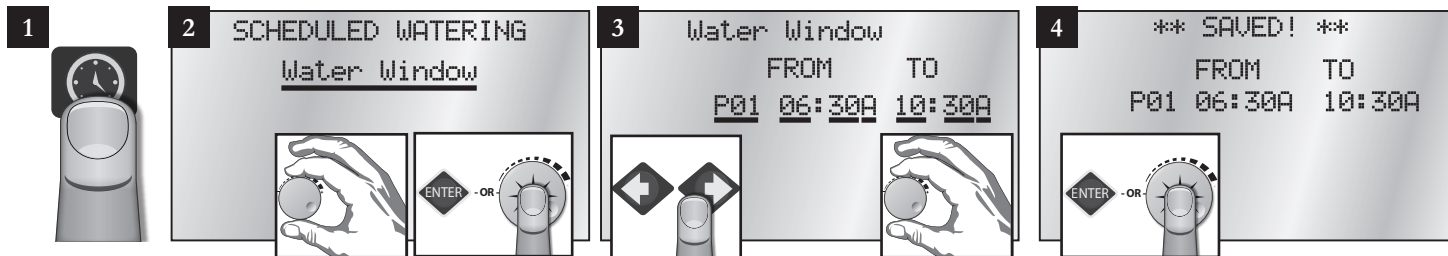

Continuous Run (2 Fields to set: Program number, Continuous Run OFF or ON)

Selecting Continuous Run will automatically repeat the program cycle continuously for the defined Water Window duration.

The controller is capable of running any one or combination of programs continuously. To manually start the desired program, use the same procedure as in Auto Slot/Stn. Use the CLUSTER SELECT and the PROGRAM SELECT keys to select the desired cluster program. Use the ON and OFF keys to turn continuous run on and off. Press ENTER to save. Use Water Windows below to set up continuous run start and stops automatically.

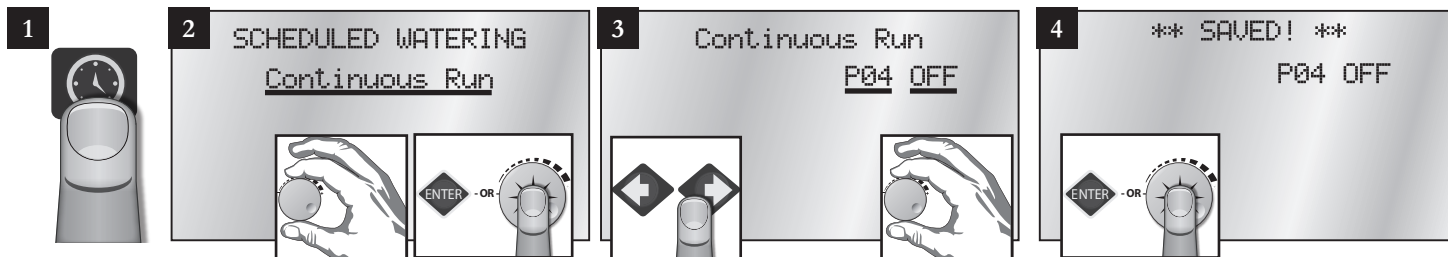

Cycle Delay (2 Fields to set: Program number, minute delay)

Places a delay period, ranging from 0 to 255 minutes, between program repeats. (See **Repeats**, below.) Use this menu item to display/edit the repeat delay time for any one of the 16 programs.

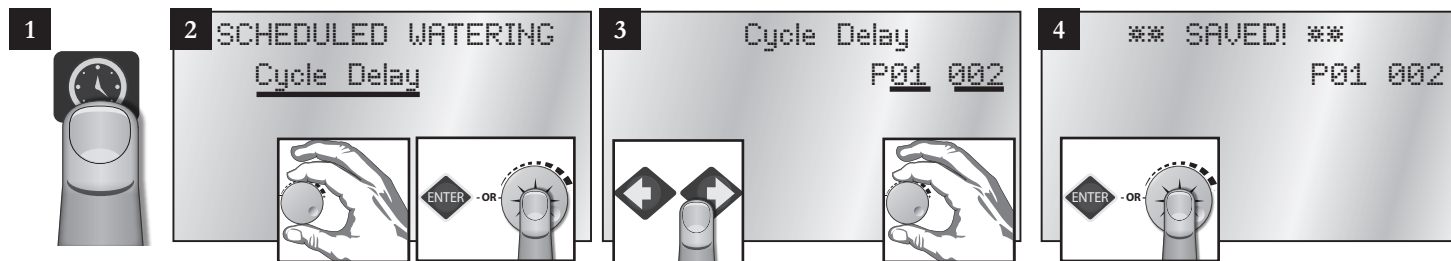

Repeats (2 Fields to set: Program number, repeat value)

Enables the watering cycle to be repeated from 1 to 255 times per start time.

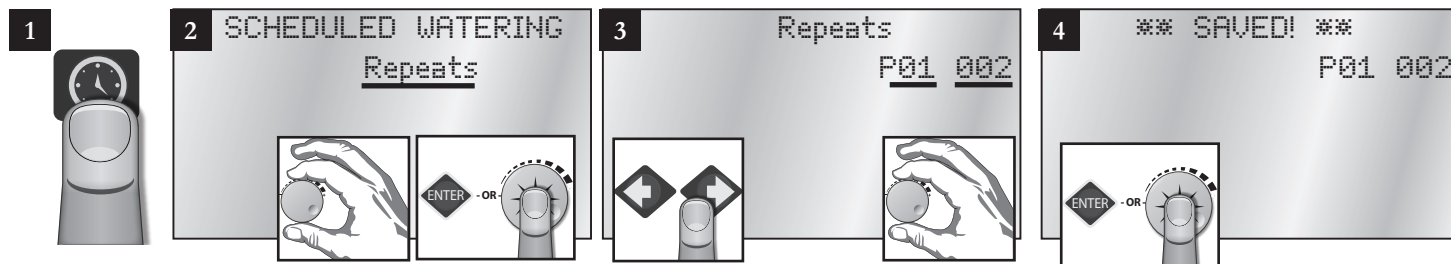

Percent Scale (2 Fields to set: Program number, percent value)

Adjusts the run time of stations assigned to the program by percentage ranging from 0 to 255% (100% = no change).

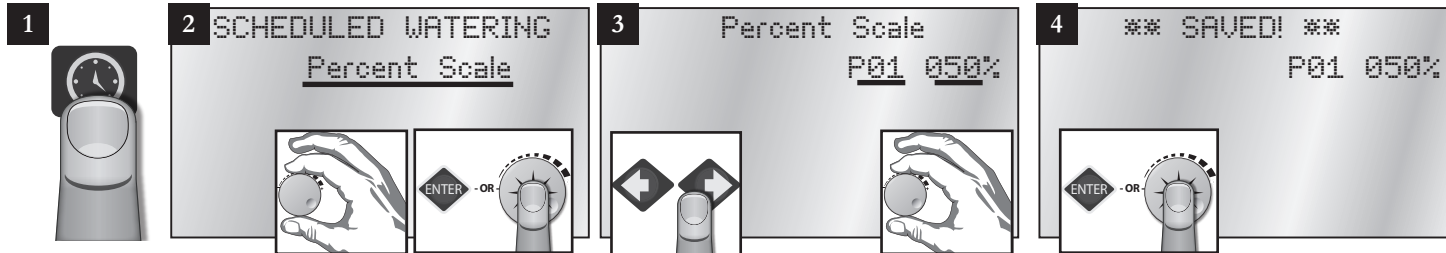

Slot-Station-Time (5 Fields to set: Program number, slot, station, run time duration hour and minute)

One of the most powerful programming features of the Sentinel Controller is the method used to organize and control satellite station outputs, referred to as “Program Slots”, within each irrigation program. “Program Slots” are organized in a sequential matrix from Slot 1 to Slot 48, for a total of 48 slot positions. From the factory, the Slot and Station numbers are set to be the same; i.e., Station 1 is assigned to Slot 1 and will run first. Station 2 will run next in Slot 2, etc.

The program operating sequence runs from Slot 1 to 48. Stations are assigned to a slot and given a run time duration ranging from 0 to 4 Hour and 15 Minutes. Station numbers range from 0 (inactive) to 48. Stations can be assigned to slots in any order and as many times as desired (that is, one station can appear multiple times in the 48 Slots of one program).

When an irrigation program is running, any slot with 0 (or blank) run time is ignored. A slot with an assigned run time duration ≥ 1 minute, but without a station assignment, will create a pause in the watering cycle for the assigned duration.

Sentinel programming allows reconfiguring the operating order of the stations by enabling any station to be assigned to any slot.

Note: *This feature (The Slots in a Program) allows the user to run any station in any order desired and even repeat the desired station within the same program. Keep in mind that the controller will run the slots sequentially. Stations can be assigned to slots allowing any order of programming.*

Visually, the Slots can be represented in a matrix as follows:

Slot	Stn	Time	Slot	Stn	Time	Slot	Stn	Time	Slot	Stn	Time	Slot	Stn	Time
1			2			3			4			5		
6			7			8			9			10		
11			12			13			14			15		
16			17			18			19			20		
21			22			23			24			25		
26			27			28			29			30		
31			32			33			34			35		
36			37			38			39			40		
41			42			43			44			45		
46			47			48								

To program Slot Station Times:

1 

2 SCHEDULED WATERING
Slot-Stn-Time

3 Slot-Stn-Time
P16 46-202-4:59

4 ** SAVED! **
P16 46-202-4:59

Chapter 3: Advanced Programming

This section covers Menus and Submenus not covered as part of Basic Programming: Manual Watering, Stop Menu, and Diagnostics and Alarms.

I. Manual Watering



- Manual
- Start / Stop Program

Manual (2 Fields to set: Station number and duration of manual run)

It is possible to manually operate up to six stations at one time. As shown in Step 3, use the Control Knob to select the station to run. Then press ENTER or the Control Knob. The default run time is 30 minutes. It is possible to adjust the run time manually at any time during the run time.

Activating a station requires power. Exceeding the maximum allowable output current when turning on multiple stations will one, cause the controller to automatically turn off the station that caused the condition, and two, flag the station so that it will not run again. This is a safety feature that prevents an over-current condition from exceeding the output capacity of the satellite. If the station is checked and found to be electrically safe, remove the disable flag through the Over Currents (Alarms) menu item.

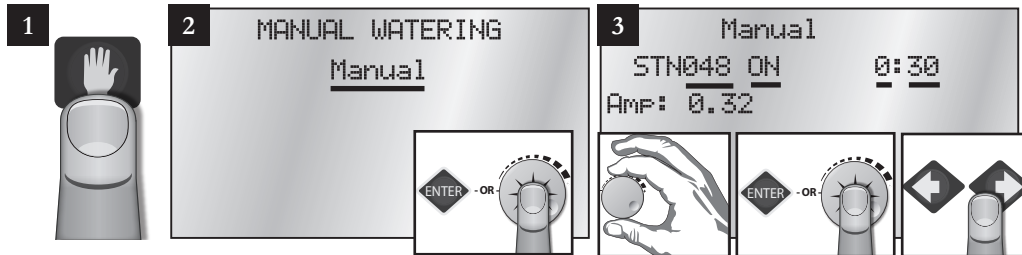

Start / Stop Program (3 Fields to set: Program number, ON or OFF, and station number)

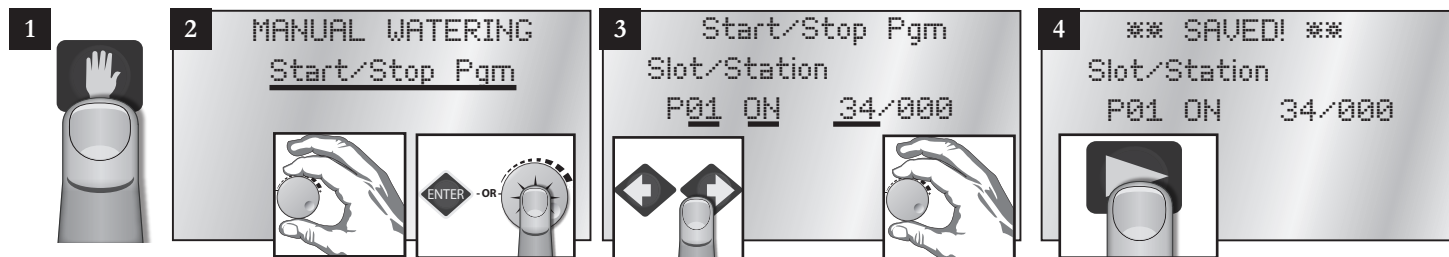

II. Stop Menu



- Full Shutdown
- All Manuals Off

- All Autos Off

Full Shutdown

Shuts down all currently active stations.

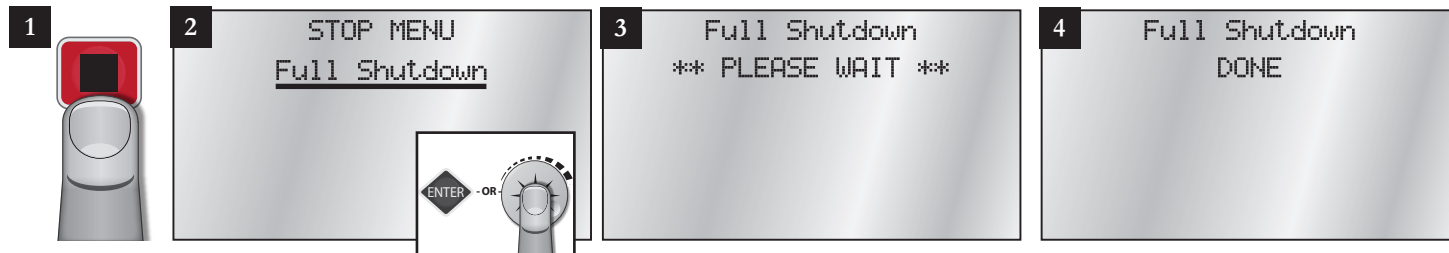

All Manuals Off (Manual Stations Off)

Turn off any and all stations that have been turned on manually without having to select each station individually. If more than one manual station is on, the controller will turn off one station at a time every five seconds to prevent the possibility of water hammer.

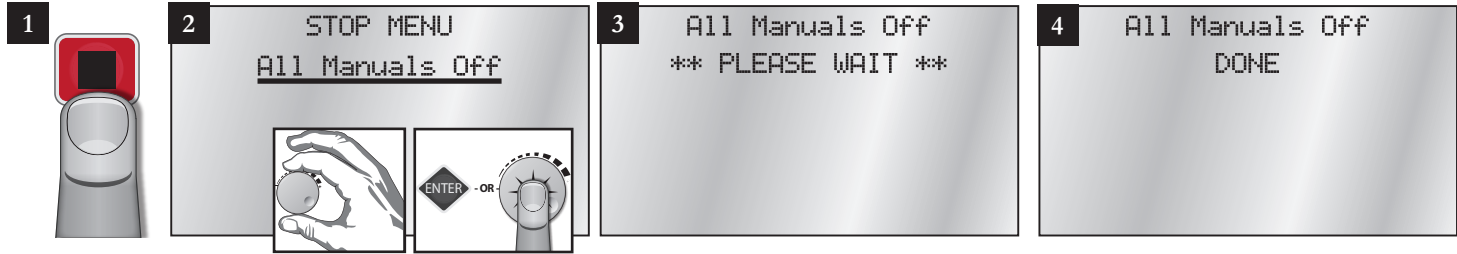

All Autos Off (Manual / Auto Programs Off)

Turn off any automatic programs (or manually started programs) that may be running.

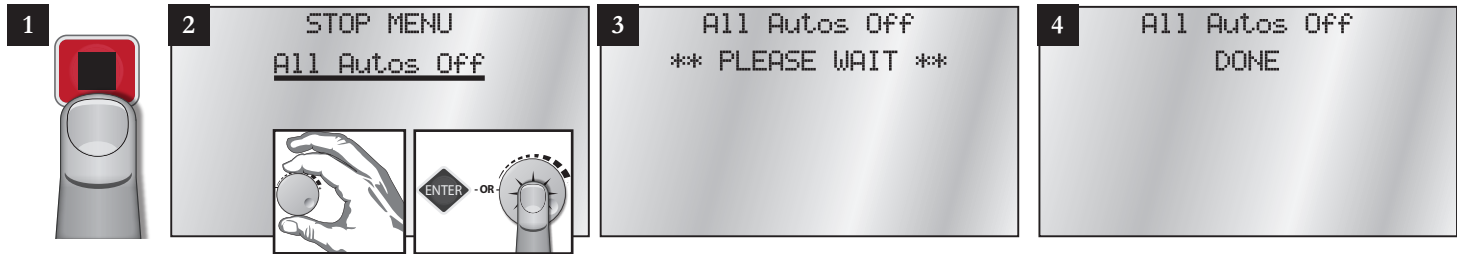

III. Diagnostics and Alarms Menu



- Show Alarms & Warnings
- Clear Sat. Alarms
- Clear Comm. Alarms
- Clear Elec. Alarms
- Clear Flow Alarms

Note: *The controller is capable of posting alarms when it detects excessive water flow or excessive current.*

Show Alarms & Warnings

Show any current alarms on the first line and the last time and date there was an alarm.

-
- DIAGNOSTICS & ALARMS
Show Alarms&Warnines
- Show Alarms&Warnines
Found Alerts
since 01/00/99 00:00
- Show Alarms&Warnines
Stn: 005
W: Max Stns limit

UHF Radio Test

Bounces a radio communication off another satellite to test UHF radio. Requires a known good satellite to bounce transmissions off. It is necessary to set the unit code of the known good satellite.

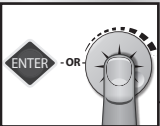
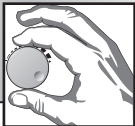
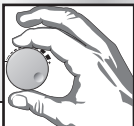
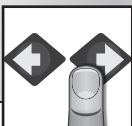
-
- DIAGNOSTICS & ALARMS
UHF Radio Test

- UHF Radio Test
02/02 100% SUCCESS
Cancel Test ? YES

- UHF Radio Test
PASSED

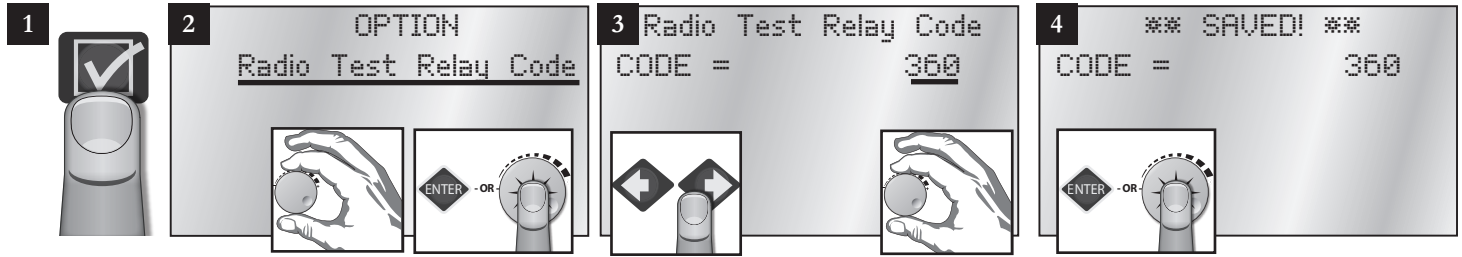
UHF Radio Test (cont'd)

Set the unit code by pressing the Option button, navigate to Radio Test Relay Code, and set with the knob and arrow keys.



Output Test

Strobes through all outputs 1 to Max Stations. This test can take a full minute to complete. Turns on the output according to the Station Type that it is (can test wireless, Toro 2-wire, Baseline 2-wire, or local outputs).

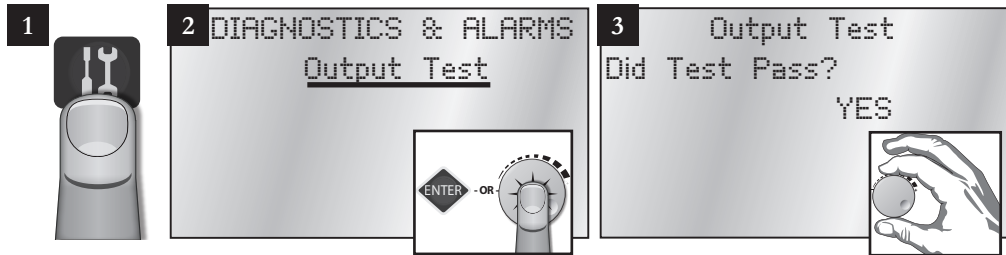

Local Output Test

Requires a light board to check outputs. Quickly strobes through the first 48 outputs one at a time. Applies only if controller is equipped with local outputs (connectors for one or more of 1-12,13-24, 25-36, 37-48).

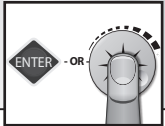
- 
- 

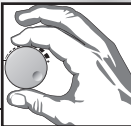
2 DIAGNOSTICS & ALARMS
Local Output Test
- 

3 Local Output Test
02/02 100% SUCCESS
Cancel Test ? YES
- 4 Local Output Test
PASSED

Keypad Test

Test routine prompts the operator to press keys and operate the Control Knob. This test also flashes the LED's on the keypad one at a time to check LED's.

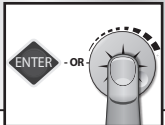
- 
- 

2 DIAGNOSTICS & ALARMS
Keypad Test
- 

3 Keypad Test
Key Test:
UP ARROW
- 4 Keypad Test
PASSED

Display Test

Will clear display and turn on every pixel one line at a time. Watch display for any missing or stuck pixels.

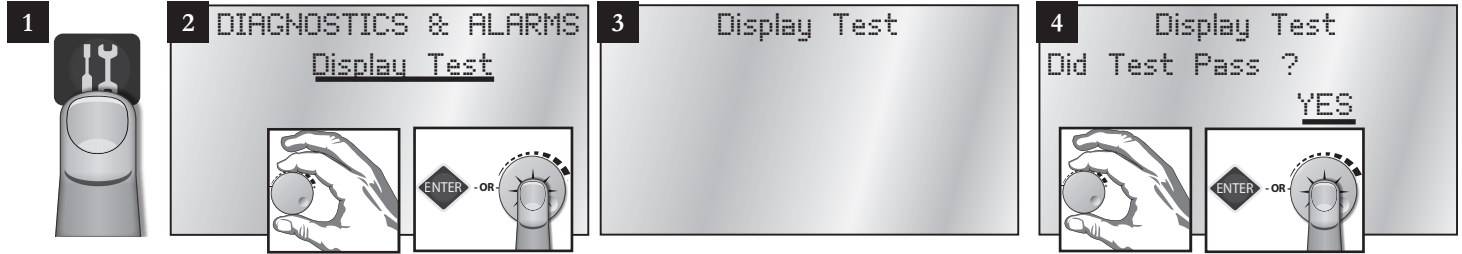

Port 1/Front Test

Check the hardware function of the port. Requires a loop back adapter plugged into the port to test. Otherwise the test will fail.

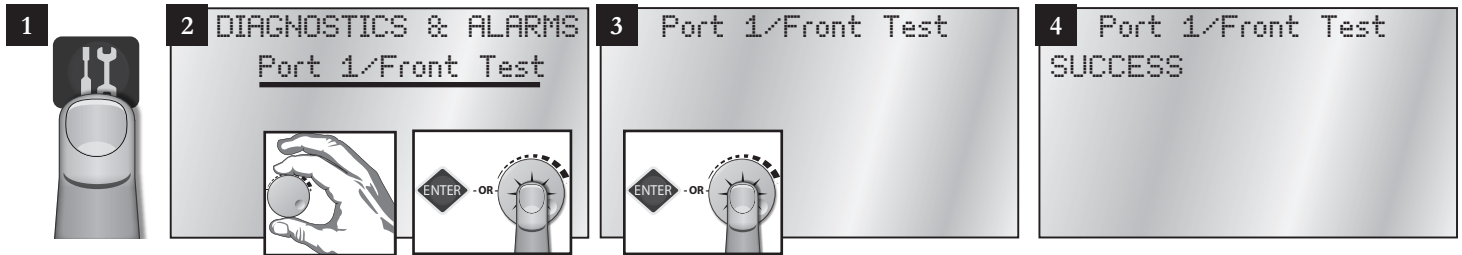

Port 0/Back Test

Check the hardware function of the port. Requires a loop back adapter plugged in to the port to test. Otherwise the test will fail.

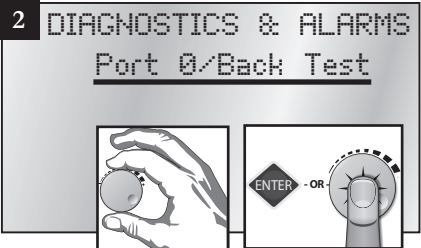
- 
- 

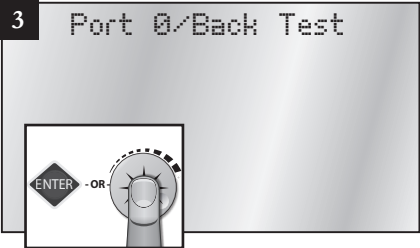

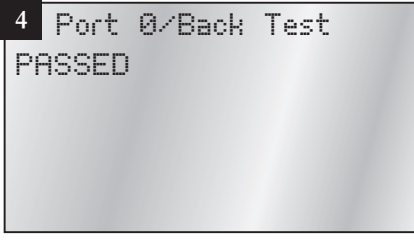
```
DIAGNOSTICS & ALARMS
  Port 0/Back Test
```
- 

```
Port 0/Back Test
```
- 

```
Port 0/Back Test
PASSED
```

Clear Sat. Alarms

Clear all Satellite alarms on all stations. Normal program operation will then resume.

- 
- 

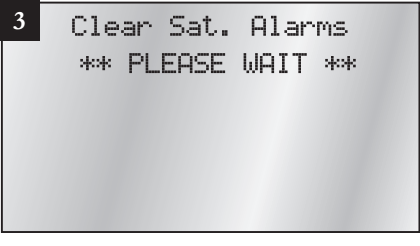

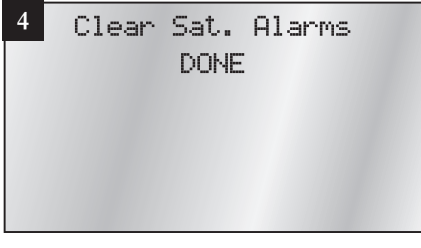
```
DIAGNOSTICS & ALARMS
  Clear Sat. Alarms
```
- 

```
Clear Sat. Alarms
** PLEASE WAIT **
```
- 

```
Clear Sat. Alarms
DONE
```

Clear Comm. Alarms

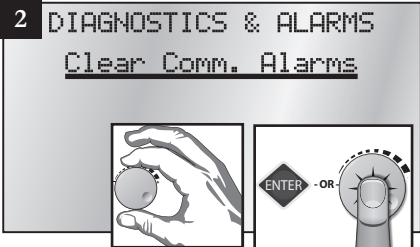
Clear all communication alarms on all stations. Normal program operation will then resume.

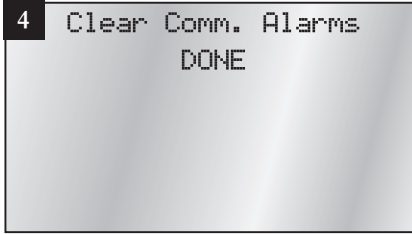
- 
- 
- 
- 

Clear Elec. Alarms

Clear all electrical alarms on all stations. Normal program operation will then resume.

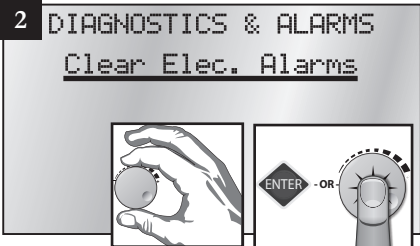
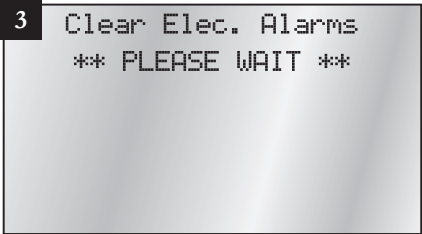
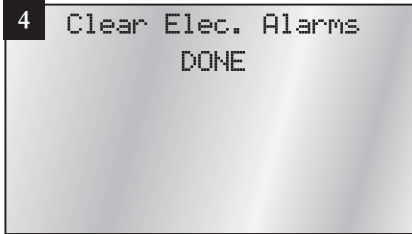
- 
- 
- 
- 

Clear Flow Alarms

Clear all flow alarms on all stations. Normal program operation will then resume.

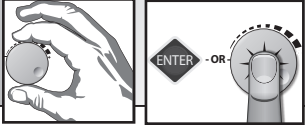
-  1
-  2 DIAGNOSTICS & ALARMS
Clear Flow Alarms
- 3 Clear Flow Alarms
** PLEASE WAIT **
- 4 Clear Flow Alarms
DONE

Show Moisture Data

When equipped with an optional Turf Guard receiver module, incoming moisture packets are displayed on screen and recorded to a log file. When connected to the Internet via the Ethernet connection, moisture data is sent to the Turf Guard servers.

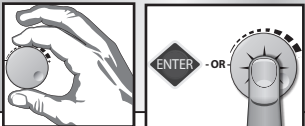
-  1
-  2 DIAGNOSTICS & ALARMS
Show Moisture Data
- 3 Show Moisture Data
No Data Found

IV. Station Settings



- Plant Factor
- Stn Days Off
- Maximum Flows
- Expected Flows
- Map Stations
- Station Type
- Precip Rate

Plant Factor (2 Fields to set: Station number and percentage)

Assign a percentage factor (0 - 255%) to any zone for the type of plant material that the zone is irrigating. For instance, it is possible to assign a bluegrass turf zone a factor of 100% and a ground cover zone that needs less water a 50% factor.

1

2 STATION SETTINGS
Plant Factor

3 Plant Factor
STN 048 255%

4 ** SAVED! **
STN 048 255%

Station Days Off (2 Fields to set: Station number and number of days off)

Disable individual stations for the number of days specified. The Hold LED will be on during Station Days Off. The days will automatically decrement each day at the Day Change Hour until Days Off is zero. The station will then resume normal operation.

1

2 STATION SETTINGS
Stn Days Off

3 Stn Days Off
STN 001 007

4 ** SAVED! **
STN 001 007

Maximum/Minimum Flows (2 Fields to set: Station number and max/min flow in GPM)

Specify/enter the maximum or minimum flow values in gallons per minute for each individual station.

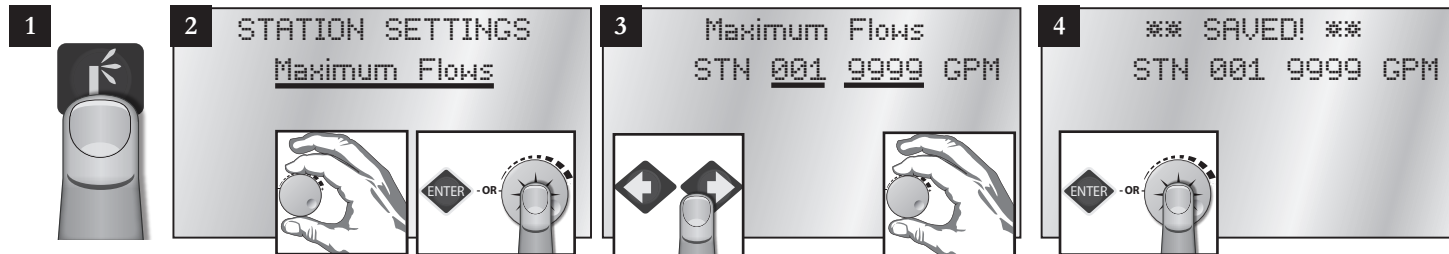

Expected Flows (2 Fields to set: Station number and expected flow in GPM)

Enter/edit the Expected Flow values (in gallons per minute) for individual stations. Expected flow values will be displayed even if there is no flow meter to collect and read actual flow values.

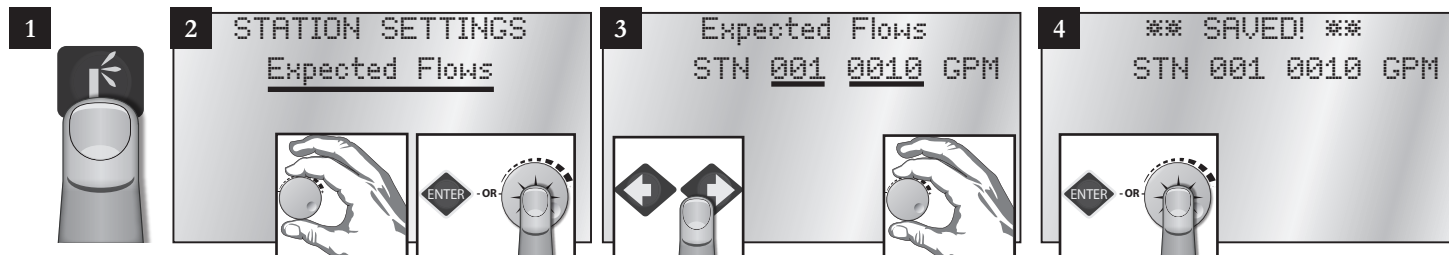

Map Stations (4 Fields to set: Station number, station type codes and parameters)

Each station can be mapped to, or associated with, hardware other than the Sentinel controller output board. This setting relates to “Station Type” as set below.

The Map Stations menu item is in the form of: SS -> AAA/BBB:CC (See programming chart below)

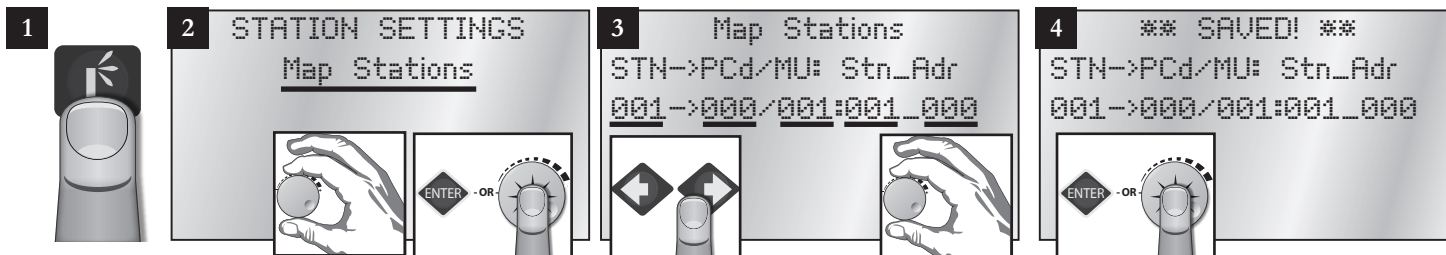

Each station can be mapped to, or associated with, other hardware by way of the 8 numbers to the right of the arrow. The field labeled SS is the Sentinel station to be mapped (01-48). The rest of the fields depend on the Station Type programming (below).

Station Type	Programming
LOCAL	No mapping necessary, any values entered are ignored.
UNIVERSAL (not supported by ver. 3 satellites)	Set AAA = 000 Set BBB = unit code of map to universal field unit Set CC = map to universal output number
TORO-2WD (Toro Two-Wire TSD models):	Set AAA/BBB = 0xx/xxx where x is the 5 digit decoder address Set CC = decoder output number 01-04
WIRELESS and WIRELESS-LR	Set AAA = board group Set BBB = 00x where x is the switch position (board number) Set CC = output number (1 - 12).

BASELINE	Set AAA/BBB:CC = 000/001:xx where xx is decoder address. We set BBB = 001 (address of Baseline gateway connected to Sentinel serial port). CC decoder address maps to a specific physical decoder (serial number) in the Baseline Setup Software.
TORO-AC-2W	Toro AC Decoder module station types. CC decoder address maps to a specific physical decoder (serial number) in the Sentinel AC 2-Wire setup.

Station Type (2 Fields to set: Station number and station type)

The following station types are available:

UNIVERSAL – Use this option to turn on outputs locally and on a universal map to (when mapped). (This is the default option.)

LOCAL – Use this option to turn outputs on locally (out the front of the satellite).

BASELINE – Use this option to turn output on locally and on Baseline AC two-wire SBDB models system.

WIRELESS – Choose this option to run outputs on a wireless output board.

TORO-2WD - Use this option to turn output on locally and on Toro DC two-wire SBD or TSD models system.

WIRELESS-LR (long range) - Allows operation of wireless output boards via a long range radio connected to one of the Sentinel satellite's external serial ports.

TORO-AC-2W - Use this option to run outputs from a Sentinel AC 2-Wire SBA models system.

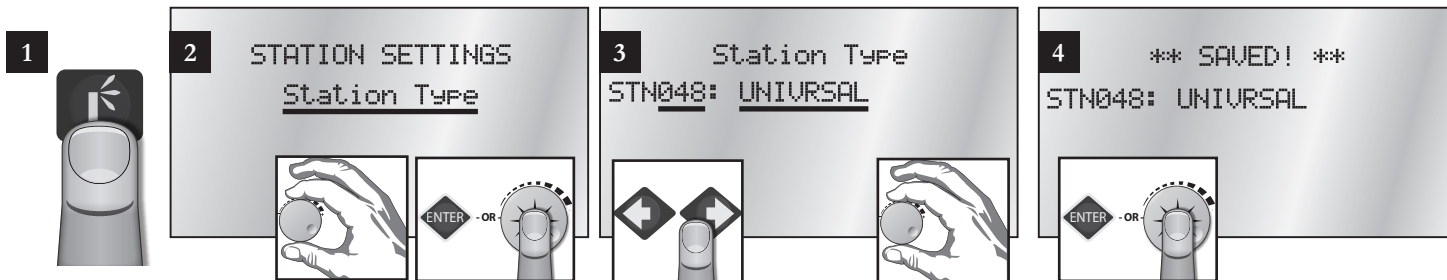

Precipitation Rate (2 Fields to set: Station number and precipitation rate)

This is the amount of water a zone applies in inches per hour. For example, a zone of fixed spray heads may apply the water at the rate of 2" per hour while a rotary sprinkler zone may apply water at the rate of 0.50" per hour.

It is possible to determine a zone's application rate by multiplying its gallons per minute by 96.3 and dividing that figure by the square feet covered by the zone.

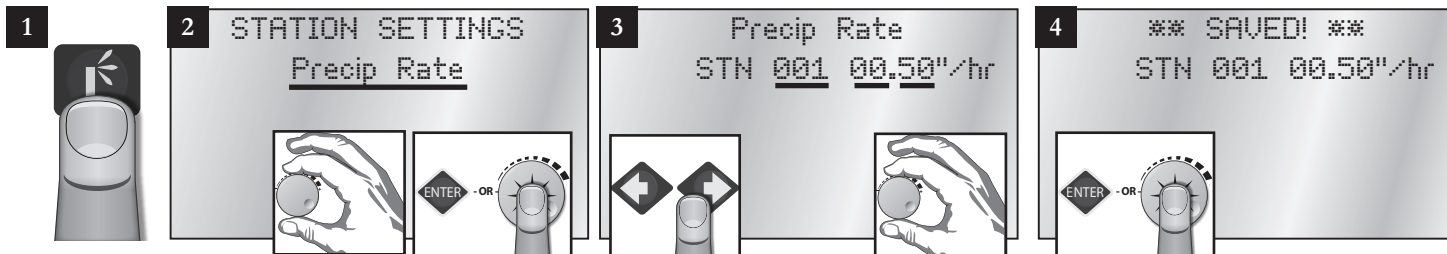

V. Option Menu

Radio Test Relay Code

The radio test relay code is the unit code of a satellite that will be used when executing the UHF radio test. The radio test relay should be executed with a known good satellite within radio range of the satellite under test.

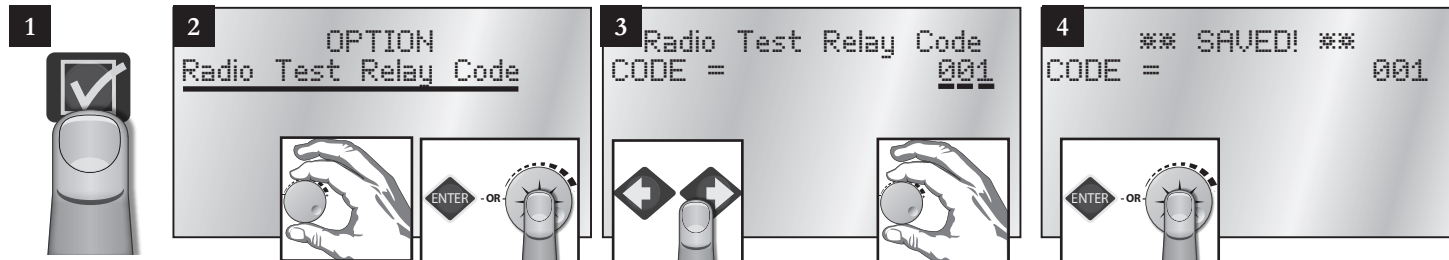

Port 0/Bk Function

Enables the port to be used for a specific function such as CTM, Long Range Wireless, Toro DC 2-wire, AC 2-Wire, etc.

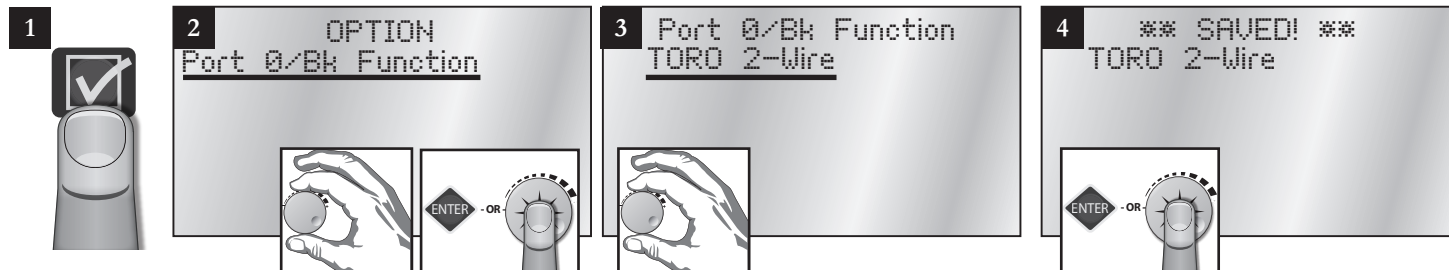

Port 1/Ft Function

Enables the port to be used for a specific function such as CTM, Long Range Wireless, Toro DC 2-wire, Sentinel AC 2-Wire, etc.

1 

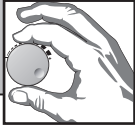
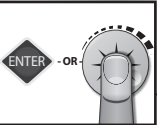
2   OPTION
Port 1/Ft Function

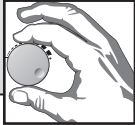
3  Port 1/Ft Function
BL/TORO AC 2-Wire

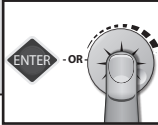
4  ** SAVED! **
BL/TORO AC 2-Wire

TCP/IP Settings

Specify TCP/IP settings. If the Sentinel satellite does *not* use DHCP, prepare to enter settings for IP address, DNS, subnet mask, and gateway.

1 

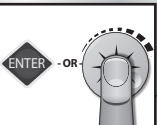
2   OPTION
TCP/IP Settings

3  TCP/IP Settings
DHCP? YES

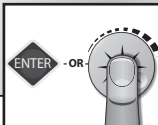
4  ** SAVED! **
DHCP? YES

BL Decoder Assign (SBDB models)

It is possible to program Baseline decoder port addresses for each decoder using the Programmer port. Reprogramming decoder addresses might be necessary if the decoders are not addressed sequentially or if decoder addresses are unknown (for example, the decoder address label has fallen off).

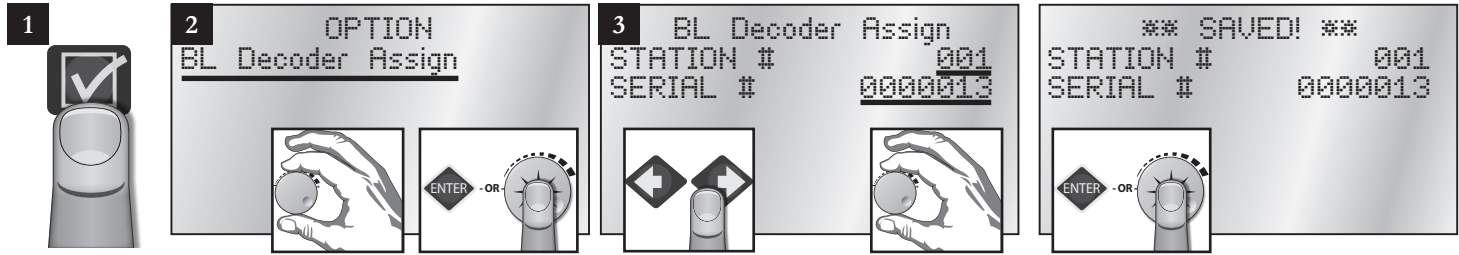

Prog Toro AC Decoder (SBA models)

It is possible to program AC decoder port addresses for each station, flow, and moisture AC decoder using the Programmer port. Reprogramming decoder addresses might be necessary if the decoders are not addressed sequentially or if decoder addresses are unknown (for example, the decoder address label has fallen off). Addresses only need to be programmed sequentially for multi-station decoders.



The decoder must be physically connected to the controller's output board to reprogram the address. To connect the decoder to the output, see illustration right.

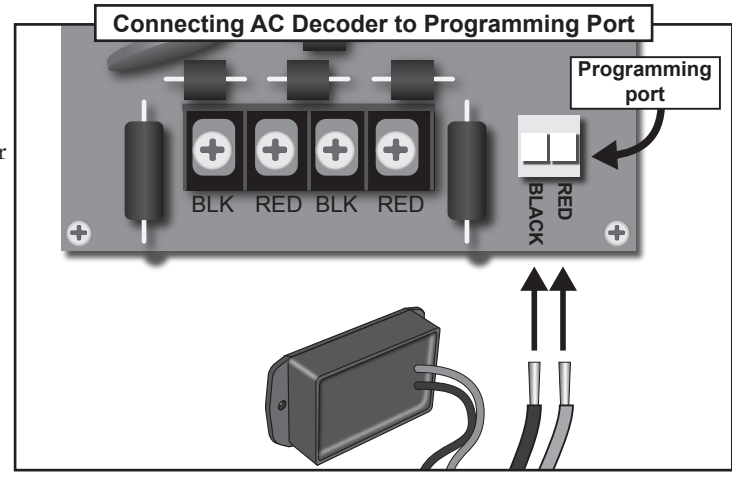

The programming screen will specify the connected decoder type (station, flow or moisture). Flow decoders will be identified with a [FLW] tag. Moisture decoders with a [MST]. A station decoder address corresponds to a station number. A flow decoder address corresponds to a flow meter number. A moisture decoder address corresponds to a moisture sensor number. If a '?' is displayed next to the decoder address, it indicates in invalid address number for the decoder type.

- Station Decoders Address Range: 1 - 204
- Flow Decoders Address options: 3, 4, and 5
- Moisture Decoders Address Range: 1 - 16

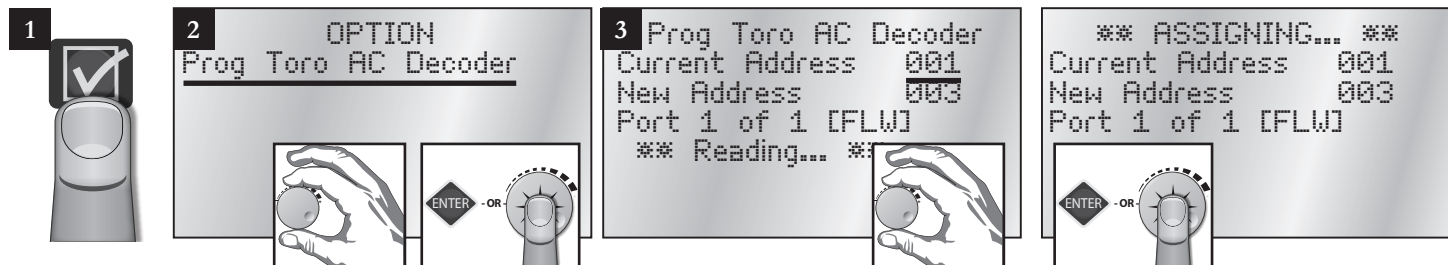

Chapter 4: Sentinel AC 2-Wire Addendum

Getting the Sentinel satellite to work with an AC 2-Wire system requires a few extra steps.

Steps

1. Confirm the serial port connected to the 2-Wire output board is set to **BL/TORO AC 2-Wire**.



The instructions below assume the 2-Wire output board is connected to serial port 1 (from bottom of TM).

- a. Press Option button. Select **Port 1/Ft Function**.
- b. Use Knob to select **BL/Toro AC 2-Wire**. Press ENTER.

```
Port 1/Ft Function
BL/TORO AC 2-Wire
```

2. For all decoder stations, confirm that the Station Type is set to **Toro AC 2-Wire**.

- a. Press Station Settings button. Select **Station Type**.
- b. Use the Control Knob to adjust the station number. Every station should already be set to **Toro-AC-2W**.
- c. If a station is not, use the right-arrow button to move to the Station Type field.
- d. Use Knob to select **Toro-AC-2W**. Press ENTER.

```
Station Type
STN 001: TORO-AC-2W
```

3. The stations must then be mapped to the particular decoder address. The address of each decoder should be affixed to each individual decoder.
 - a. Press Station Settings button. Select **Map Stations**.
 - b. Use Knob to select desired station.
 - c. Use arrow buttons to move to **Stn_Adr** field.
 - d. Use Knob to adjust value as necessary. Press ENTER.
 - e. Repeat as necessary.

```
Map Stations
STN->PCd/MU:Stn_Adr
001->000/001:001_000
```

4. If necessary, it is possible to reprogram the address for each decoder using the Programmer port. Reprogramming decoder addresses might be necessary if the decoders are not addressed sequentially or if decoder addresses are unknown (for example, the decoder address label has fallen off).
 - a. Press Option button. Select **Prog Toro AC Decoder**.
 - b. Use Knob to adjust **New Address** value. Press ENTER.

```
Prog Toro AC Decoder
Current Address  001
New Address     002
Port 1 of 1
```



If you change the decoder address you must change the station mapping to match.



Multi station decoder addresses must be sequential. (Station 1 on a two station decoder = 005, Station 2 on the same decoder = 006.) If you reprogram multistation decoder addresses so that they are not sequential (Station 1 = Decoder 005, Station 2 = Decoder 010), the irrigation program will not work.

Frequently Asked Questions

1. How do I update the firmware and language programming?

For complete instructions on how to update the firmware programming and languages for the Sentinel system, go to the Sentinel support website at: <http://www.toro.com/sentinel>.

2. I have cleared all alarms, but the alarm indicator is still blinking.

There are three possibilities: One, there may be an external alarm; two, the date and time might still have to be set; or three, so many stations are running a volumetric shutdown has been triggered.

3. What happened to 2Wire/Irritrol Mode?

2Wire/Irritrol Mode has been removed from the keypad menu and is no longer being used. We do not send anything on any port that has not been requested, so it is no longer possible to connect a 2-wire gateway. The only commands sent to that port were for the 2-wire gateway. As a result, this flag is no longer needed.

Troubleshooting Guide

Problem	Possible Cause	Solution
No display.	AC power not reaching controller. Blown fuse. 14-pin ribbon-cable connector is not fully connected.	Check and fix AC power supply to controller. Check fuses. Determine why blown and replace if necessary. Check ribbon cable connections on bottom of unit.
Controller does not irrigate as scheduled.	Programming error. Time and date error. Sensor is shutting down system. Station Alarms set.	Verify programming information with Central or In Display. Verify time and date. Remove sensor, clear, and retest. Look for alarms. Correct issue if set, and clear alarms.
Water does not turn ON.	Programming error. Faulty valve wire connections. Bad / defective solenoid or valve. Flow control or water shut off.	Verify programming information with Central or In Display. Look for alarms. Correct issue if set, and clear alarms. Test for 24 VAC from Station Post to Common or Ground with Manual switch on. Check flow control valve and water supply line.
Water does not turn OFF.	Programming error--too many start times. Bad / defective solenoid. Valve blockage.	Verify programming information with Central or In Display. Test for 24 VAC from Station Post to Common or Ground with Controller running and/or Manual switch on. Check for cross connections between stations. Shut off power at controller. If station stays on, isolate and troubleshoot valve.
Rain sensor does not shut down system.	Programming error. Faulty sensor or faulty sensor connection.	Verify programming information with Central or In Display. Verify and reset.

Toro Warranty and Dedication to Quality

The Toro Company and its affiliate, Toro Warranty Company, pursuant to an agreement between them, jointly warrants, to the owner, against defects in material and workmanship for a period of five years from the date of purchase. Neither The Toro Company nor Toro Warranty Company is liable for failure of products not manufactured by them even though such products may be sold or used in conjunction with Toro products. During such warranty period, we will repair or replace, at our option, any part found to be defective. Return the defective part to the place of purchase. Our liability is limited solely to the replacement or repair of defective parts. There are no other express warranties. This warranty does not apply where equipment is used, or installation is performed, in any manner contrary to Toro's specifications and instructions, nor where equipment is altered or modified. Neither The Toro Company nor Toro Warranty Company is liable for indirect, incidental or consequential damages in connection with the use of equipment, including but not limited to: vegetation loss, the cost of substitute equipment or services required during periods of malfunction or resulting non-use, property damage or personal injury resulting from installer's negligence.

Some states do not allow the exclusion or limitation of incidental or consequential damages, so the above limitation or exclusion may not apply to you. All implied warranties, including those of merchantability and fitness for use, are limited to the duration of this express warranty. Some states do not allow limitations of how long an implied warranty lasts, so the above limitation may not apply to you. This warranty gives you specific legal rights and you may have other rights which vary from state to state.

Toro is committed to developing and producing the highest quality, best performing, most dependable products on the market. Because your satisfaction is our first priority, we have provided the Toro Helpline to assist you with any questions or problems that may arise. If for some reason you are not satisfied with your purchase or have questions, please contact your local authorized Toro dealer or e-mail irrigation.support@toro.com.

FCC Statement

This equipment has been tested and found to comply with the limits for a Class A digital device, pursuant to part 15 of the FCC Rules. These limits are designed to provide reasonable protection against harmful interference in a residential installation. This equipment generates, uses and can radiate radio frequency energy and, if not installed and used in accordance with the instructions, may cause harmful interference to radio communications. However, there is no guarantee that interference will not occur in a particular installation. If this equipment does cause harmful interference to radio or television reception, which can be determined by turning the equipment off and on, the user is encouraged to try to correct the interference by one or more of the following measures:

- Reorient or relocate the receiving antenna.
- Increase the separation between the equipment and receiver.
- Connect the equipment into an outlet on a circuit different from that to which the receiver is connected.
- Consult the dealer or an experienced radio/TV technician for help.

If necessary, the user should consult the dealer or an experienced radio/television technician for additional suggestions. The user may find the following booklet prepared by the Federal Communications Commission helpful: "How to Identify and Resolve Radio-TV Interference Problems." This booklet is available from the U.S. Government Printing Office, Washington, D.C., Stock No. 004-000-00345-4 (price – \$2.00 postpaid).